

# YAMAHA

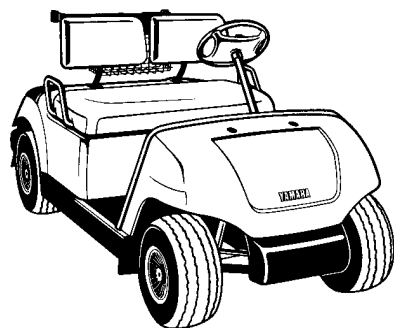

## PARTS CATALOG

**1996 G16AR**

**1997 G16AR**

**1998 G16AS**

**1999 G16AT**

**2000 G16AU**

**2001 G16AW**

(JN62) U.S.A., CANADA, EUROPE, OTHERS

# CYLINDER HEAD

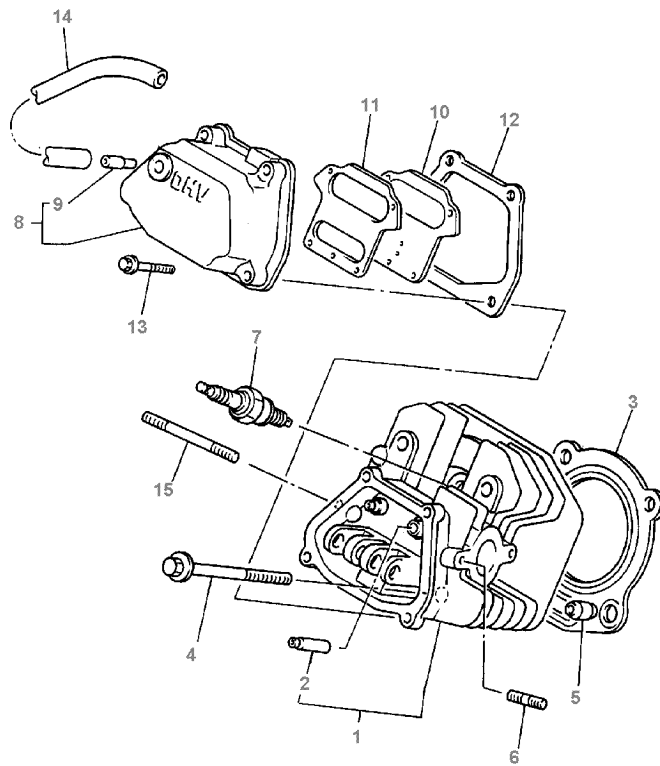

Ref. No.	Part Number	Description	Qty	Remarks
1	JN6-11102-00-00	HEAD, CYLINDER .....	1	
2	JN6-11133-10-00	. GUIDE, VALVE .....	2	
3	JN6-11181-00-00	GASKET, CYLINDER HEAD ...	1	
4	95817-10070-00	BOLT, FLANGE .....	4	
5	99530-14016-00	PIN, DOWEL .....	2	
6	95617-08618-00	BOLT, STUD (95627-08618-00) .	2	
7	NGK-BPR2E-S0-00	PLUG, SPARK .....	1	STD
8	JN6-11191-00-00	COVER, CYLINDER .....	1	
9	JN6-11116-00-00	. JOINT, BREATHER .....	1	
10	JN6-11168-00-00	COVER, BREATHER .....	1	
11	JN6-11169-00-00	GASKET, BREATHER .....	1	
12	JN6-11193-00-00	GASKET, HEAD COVER 1 ....	1	
13	95817-06030-00	BOLT, FLANGE .....	4	
14	JN6-E1166-00-00	PIPE, BREATHER .....	1	
15	95607-08710-00	BOLT, STUD .....	2	



JN7010-6010

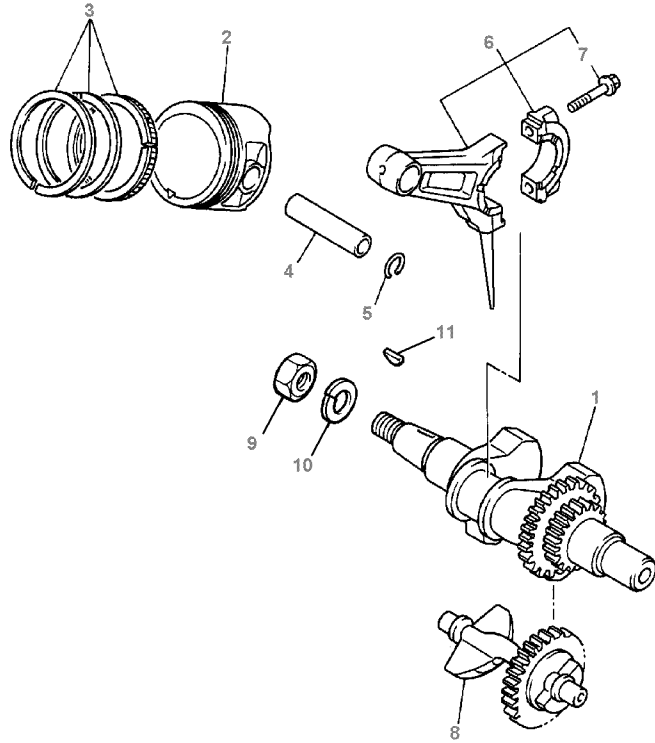

JN7010-6020

## CRANKSHAFT - PISTON

Ref. No.	Part Number	Description	Qty	Remarks
1	JN6-11400-00-00	CRANK ASSEMBLY. ....	1	
2	JN6-11631-00-A0	PISTON (STD) .....	1	STD
	JN6-11635-00-00	PISTON (0.25MM O/S) .....	1	AP
	JN6-11636-00-00	PISTON (0.50MM O/S) .....	1	AP
3	JN6-11610-00-00	PISTON RING SET (STD) .....	1	STD
	JN6-11610-10-00	PISTON RING SET (0.25MM O/S) .....	1	AP
	JN6-11610-20-00	PISTON RING SET (0.50MM O/S) .....	1	AP
4	447-11633-00-00	PIN, PISTON .....	1	
5	93450-21053-00	CIRCLIP .....	2	
6	JN6-11650-00-00	CONNECTING ROD ASSEMBLY	1	
7	JN6-11654-00-00	. BOLT, CONNECTING ROD ..	2	
8	JN6-11454-00-00	WEIGHT 1 .....	1	
9	95307-18600-00	NUT, HEX. ....	1	
10	90201-18620-00	WASHER, PLAIN .....	1	
11	90280-04052-00	KEY, WOODRUFF .....	1	

# CAMSHAFT - VALVE

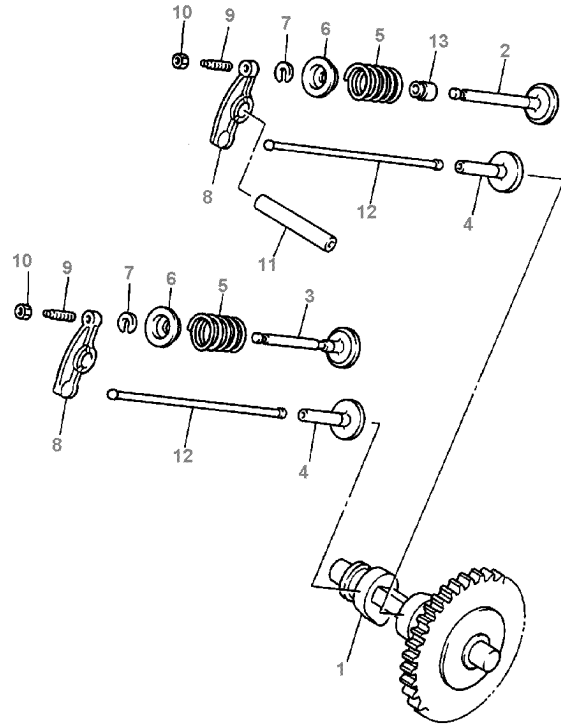

Ref. No.	Part Number	Description	Qty	Remarks
1	JN6-12171-00-00	SHAFT, CAM .....	1	
2	JN6-12111-00-00	VALVE, INTAKE .....	1	
3	JN6-12121-00-00	VALVE, EXHAUST .....	1	
4	JN6-12153-00-00	LIFTER, VALVE .....	2	
5	90501-264A9-00	SPRING, COMPRESSION .....	2	
6	J38-12117-01-00	RETAINER, VALVE SPRING ..	2	
7	J38-12118-00-00	COTTER, VALVE .....	2	
8	JN6-12151-00-00	ARM, VALVE ROCKER .....	2	
9	22F-12159-00-00	SCREW, VALVE ADJUSTING ..	2	
10	90170-05302-00	NUT .....	2	
11	J38-12156-00-00	SHAFT, ROCKER 2 .....	1	
12	JN6-12154-00-00	ROD, VALVE PUSH .....	2	
13	5H0-12119-00-00	SEAL, VALVE STEM .....	1	

 JN7010-6030

# AIR SHROUD - FAN

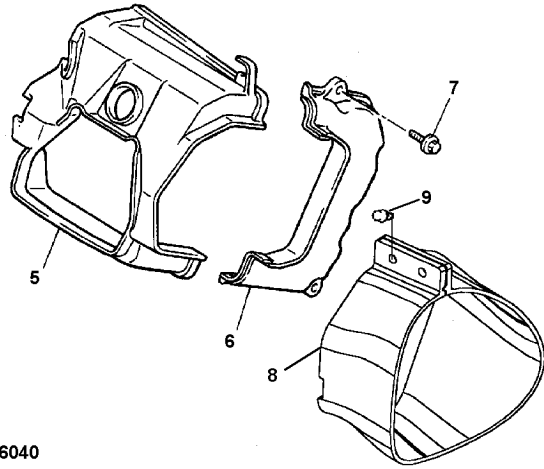
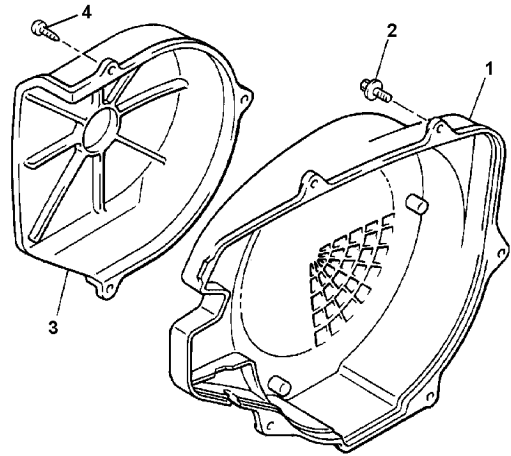

Ref. No.	Part Number	Description	Qty	Remarks
1	JN6-12621-00-00	CASE, FAN .....	1	
2	95817-06020-00	BOLT, FLANGE .....	5	
3	JN6-12616-00-00	COVER, FAN CASE .....	1	
4	97707-60520-00	SCREW, TAPPING .....	3	
5	JN6-12651-00-00	AIR SHROUD, CYLINDER ....	1	
6	JN6-12652-00-00	AIR SHROUD, CYLINDER ....	1	
7	95817-06020-00	BOLT, FLANGE .....	2	
8	JN6-E2691-00-00	DUCT, .....	1	
9	90269-08813-00	RIVET .....	2	

JN7010-6040

# INTAKE

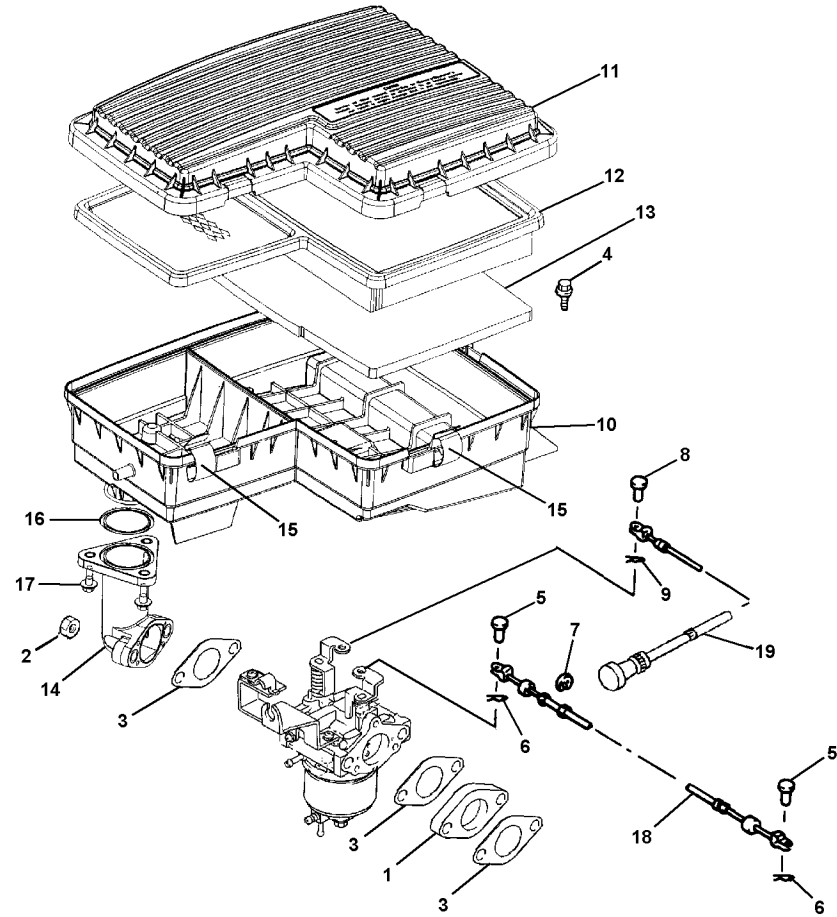

JN6100-6010

Ref. No.	Part Number	Description	Qty	Remarks
1	JN6-13595-00-00	JOINT .....	1	
2	95707-08500-00	NUT, FLANGE .....	2	
3	JN6-13567-00-00	GASKET .....	3	
4	90119-06920-00	BOLT, WITH WASHER .....	2	
5	91701-05010-00	PIN, CYLINDER. HEAD .....	2	
6	90468-10050-00	CLIP .....	2	
7	99080-07600-00	CIRCLIP (E) .....	1	
8	91701-05010-00	PIN, CYLINDER. HEAD .....	1	
9	90468-10050-00	CLIP .....	1	
10	JN6-E4411-00-00	CASE, AIR FILTER .....	1	
11	JN6-E4412-00-00	CAP, CASE .....	1	
12	JN6-E4450-00-00	ELEMENT ASSEMBLY. ....	1	
13	JN6-E445E-00-00	FILTER, .....	1	
14	JN6-E3586-00-00	JOINT, CARBURETOR .....	1	
15	JN6-E4424-00-00	CLIP, CAP FITTING .....	3	
16	93210-398D6-00	O-RING .....	1	
17	90105-06862-00	BOLT, FLANGE .....	3	
18	JN6-F6312-00-00	WIRE, THROTTLE .....	1	
19	JN6-F6331-00-00	WIRE, STARTER .....	1	

# CARBURETOR

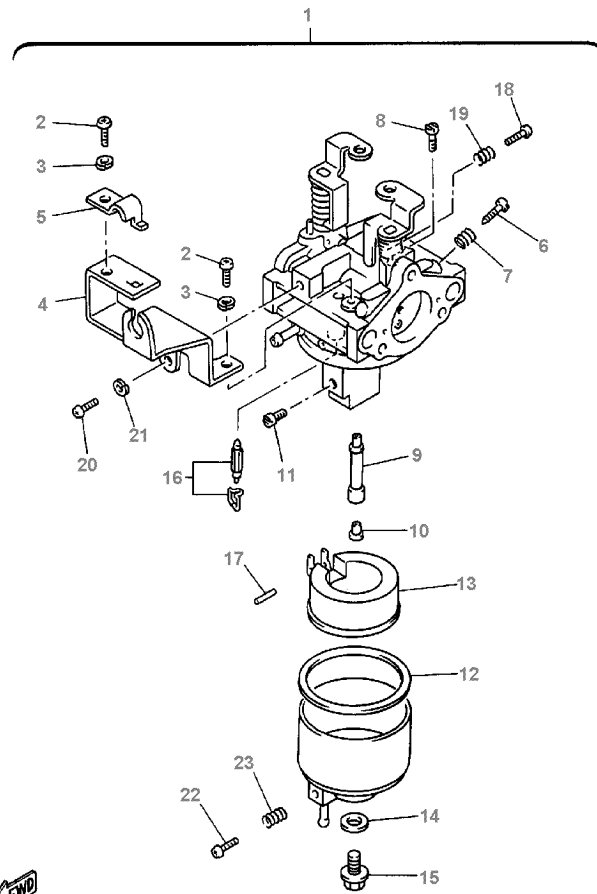

JN7010-6060

Ref. No.	Part Number	Description	Qty	Remarks
1	JN6-14101-01-00	CARBURETOR ASSEMBLY. . .	1	
2	98507-05008-00	. SCREW, PAN HEAD . . . . .	2	
3	92990-05100-00	. WASHER, SPRING . . . . .	2	
4	JN6-14291-00-00	. BRACKET . . . . .	1	
5	J10-14227-00-00	. WASHER . . . . .	1	
6	7LV-14211-00-00	. SCREW, PILOT ADJUSTING . .	1	
7	73A-14212-00-00	. SPRING . . . . .	1	
8	620-1414J-24-00	. JET, PILOT . . . . .	1	
9	JN6-1495H-3B-00	. NOZZLE, MAIN . . . . .	1	
10	73A-1414G-00-00	. PIPE, MAIN BREED . . . . .	1	
11	3G2-1423E-34-00	. JET, MAIN 1 # . . . . .	1	
12	796-14184-00-00	. GASKET, FLOAT CHAMBER . .	1	
13	7KY-14185-00-00	. FLOAT . . . . .	1	
14	127-14198-00-00	. GASKET . . . . .	1	
15	7R1-14162-00-00	. BOLT, HOLDING . . . . .	1	
16	JN5-14150-00-00	. NEEDLE ASSEMBLY . . . . .	1	
17	22F-14186-00-00	. PIN, FLOAT . . . . .	1	
18	1WG-14922-00-00	. SCREW, THROTTLE . . . . .	1	
19	73A-14212-10-00	. SPRING . . . . .	1	
20	98507-04010-00	. SCREW, PAN HEAD . . . . .	1	
21	92990-05100-00	. WASHER, SPRING . . . . .	1	
22	7E1-14191-00-00	. PLUG, DRAIN . . . . .	1	
23	73A-14212-00-00	. SPRING . . . . .	1	

# EXHAUST

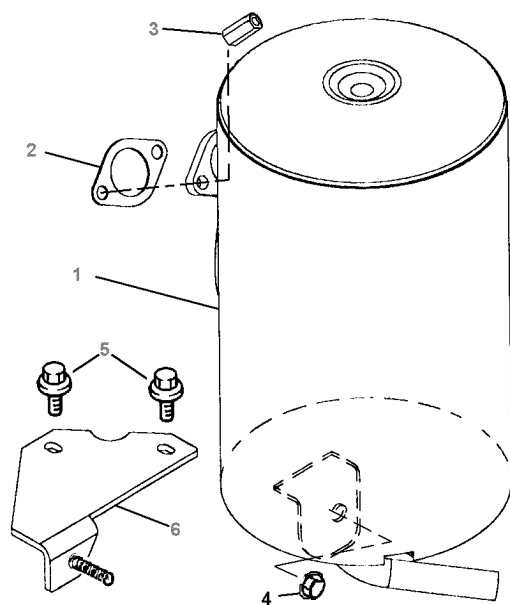

 JN6100-6020

Ref. No.	Part Number	Description	Qty	Remarks
1	JN6-E4710-00-00	MUFFLER ASSEMBLY .....	1	
2	7KY-14613-01-00	GASKET, EXHAUST PIPE ....	1	
3	90179-08879-00	NUT .....	2	
4	97507-08620-00	BOLT, HEX HEAD WWASHER	1	
5	90119-08825-00	BOLT, HEX HEAD WWASHER	2	
6	JN6-F1435-01-00	BRACKET, MUFFLER .....	1	

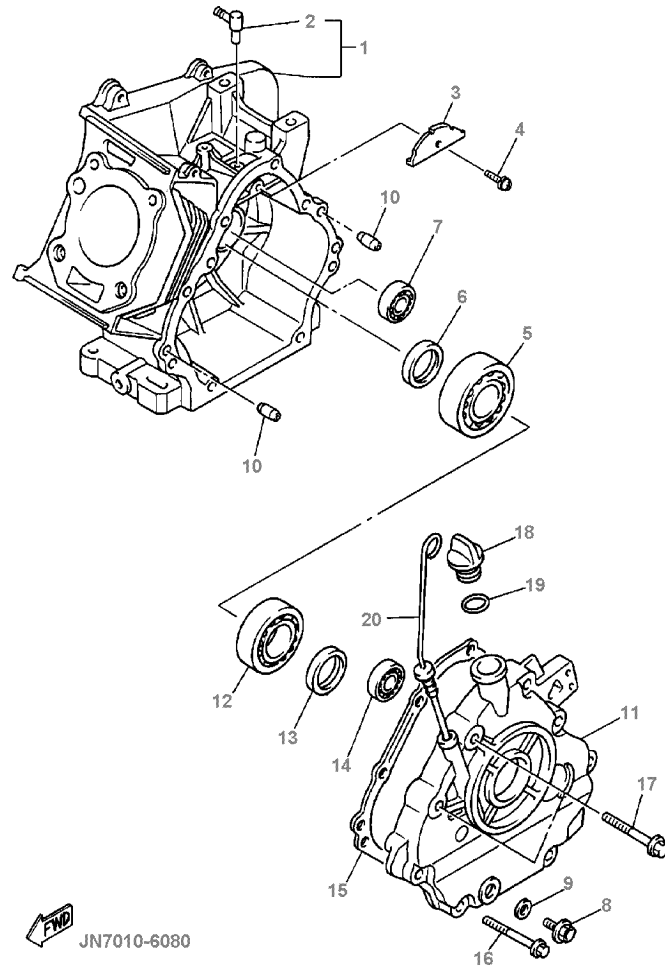

# CRANKCASE

Ref. No.	Part Number	Description	Qty	Remarks
1	JN6-15100-00-00	CRANKCASE ASSEMBLY	1	
2	JN6-15155-00-00	. NOZZLE,	1	
3	JN6-15123-00-00	PLATE, BAFFLE	1	
4	90159-06107-00	SCREW, WITH WASHER	1	
5	93306-30709-00	BEARING	1	
6	93102-35191-00	OIL SEAL	1	
7	93306-20211-00	BEARING (6202SH2-C3)	1	
8	90340-12097-00	PLUG, STRAIGHT SCREW	1	
9	812-11198-00-00	GASKET	1	
10	99510-08016-00	PIN, DOWEL	2	
11	JN6-15411-00-00	COVER, CRANKCASE	1	
12	93306-20716-00	BEARING	1	
13	93102-35191-00	OIL SEAL	1	
14	93306-20211-00	BEARING (6202SH2-C3)	1	
15	JN6-15451-00-00	GASKET, CRANKCASE	1	
16	95817-08045-00	BOLT, FLANGE	6	
17	95817-10050-00	BOLT, FLANGE	2	
18	796-15363-01-00	PLUG, OIL	1	
19	93210-22344-00	O-RING	1	
20	J38-15361-00-00	GAUGE, LEVEL	1	

# ENGINE MOUNT

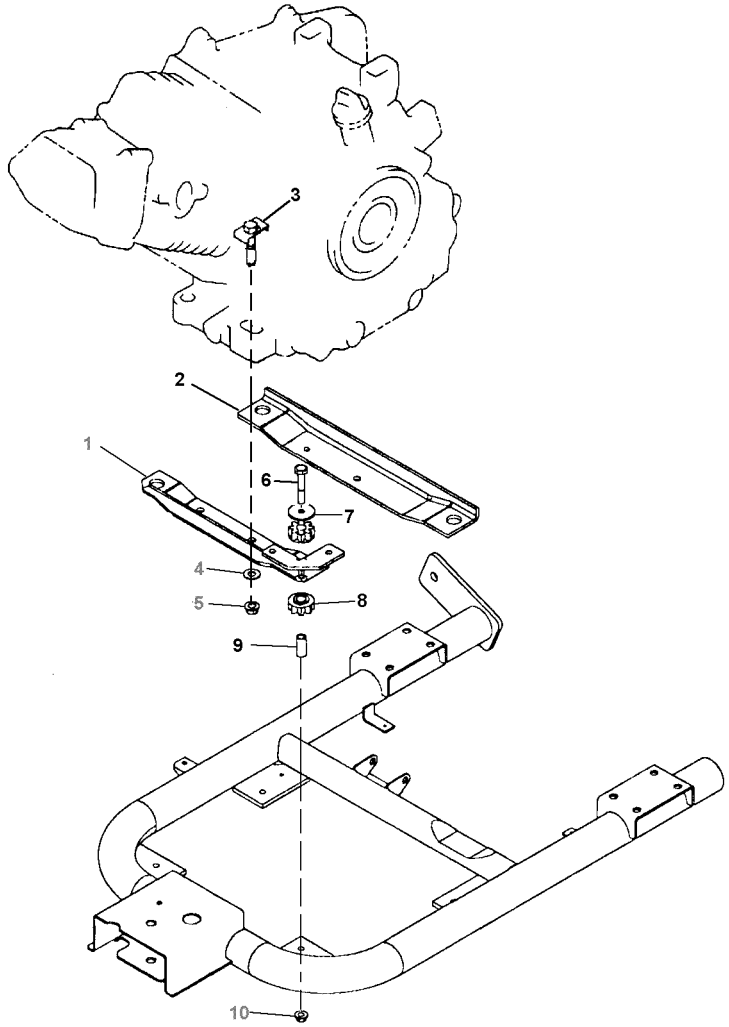

Ref. No.	Part Number	Description	Qty	Remarks
1	JN6-F1411-00-00	BRACKET, ENGINE .....	1	
2	JN6-F1419-00-00	BRACKET, ENGINE .....	1	
3	JN6-F1481-00-00	BOLT, ENGINE .....	4	
4	92907-10200-00	WASHER, PLAIN .....	4	
5	95617-10200-00	NUT, SELF-LOCKING .....	4	
6	90101-08870-00	BOLT, HEX .....	4	
7	90201-088K6-00	WASHER, PLAIN .....	4	
8	JN6-F1486-00-00	DAMPER, .....	8	
9	JN6-F1459-00-00	SPACER .....	4	
10	95617-08200-00	NUT, SELF-LOCKING (95607-08200-00) .....	4	

 JN6100-6030

# REAR ARM - SUSPENSION

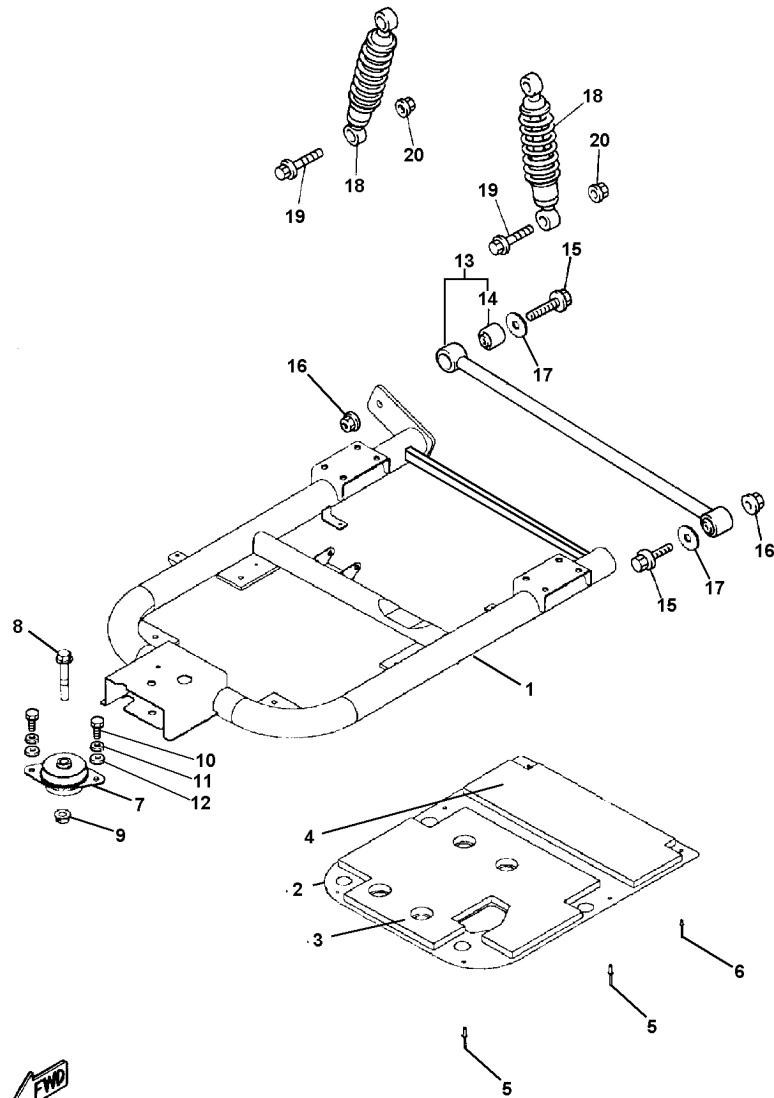

Ref. No.	Part Number	Description	Qty	Remarks
1	JN6-F2110-01-00	REAR ARM COMP. ....	1	
2	JN6-F2128-01-00	COVER, ....	1	
3	JN6-F211E-00-00	PANEL, INNER ....	1	
4	JN6-F211G-00-00	PANEL, INNER ....	1	
5	90267-48850-00	RIVET, BLIND ....	4	
6	90267-40851-00	RIVET, BLIND ....	2	
7	JN6-F2123-00-00	BUSHING, ....	1	
8	90105-13864-00	BOLT, FLANGE ....	1	
9	90179-13878-00	NUT ....	1	
10	97017-10020-00	BOLT ....	2	
11	92907-10100-00	WASHER, SPRING ....	2	
12	92907-10600-00	WASHER, PLATE ....	2	
13	JN6-F2172-00-00	ROD, CONNECTING (JN6-F217G-00-00) ....	1	
14	JN6-F2124-00-00	BUSHING, ....	2	
15	95817-12065-00	BOLT, FLANGE ....	2	
16	95617-12200-00	NUT, SELF-LOCKING ....	2	
17	90201-12426-00	WASHER, PLATE ....	2	
18	JN3-F2210-00-00	SHOCK ABSORBER ....	2	
19	95807-10055-00	BOLT, FLANGE ....	4	
20	95617-10200-00	NUT, SELF-LOCKING ....	4	



JN6100-6040

# FRAME

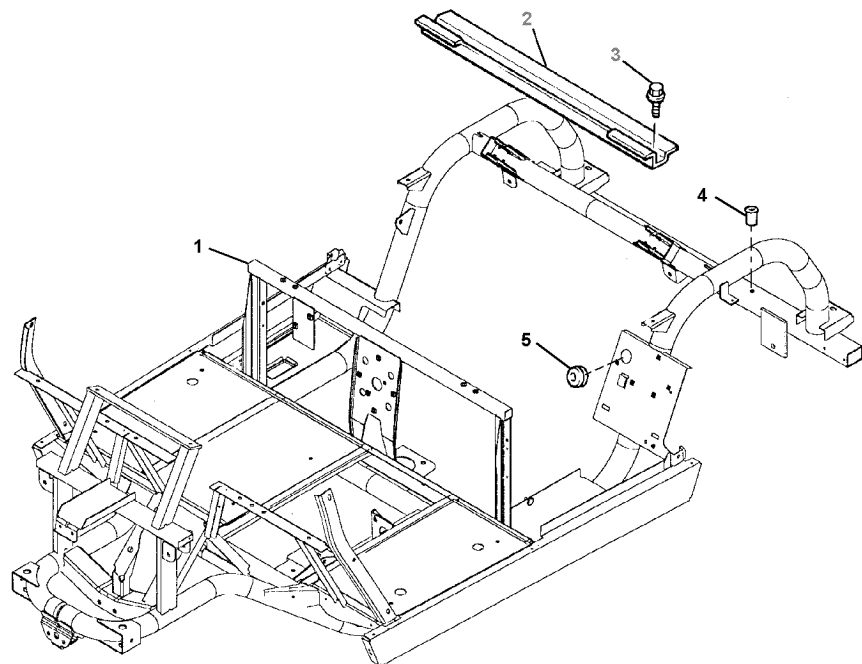

 JN6100-6050

Ref. No.	Part Number	Description	Qty	Remarks
1	JN6-F2501-00-00	FRAME COMP. ....	1	
2	JN6-F254R-00-00	SUPPORT, BODY MOUNTING .	1	
3	95817-08016-00	BOLT, FLANGE .....	2	
4	90179-06874-00	NUT .....	2	
5	90480-25856-00	GROMMET .....	1	

# FRONT SUSPENSION - WHEEL

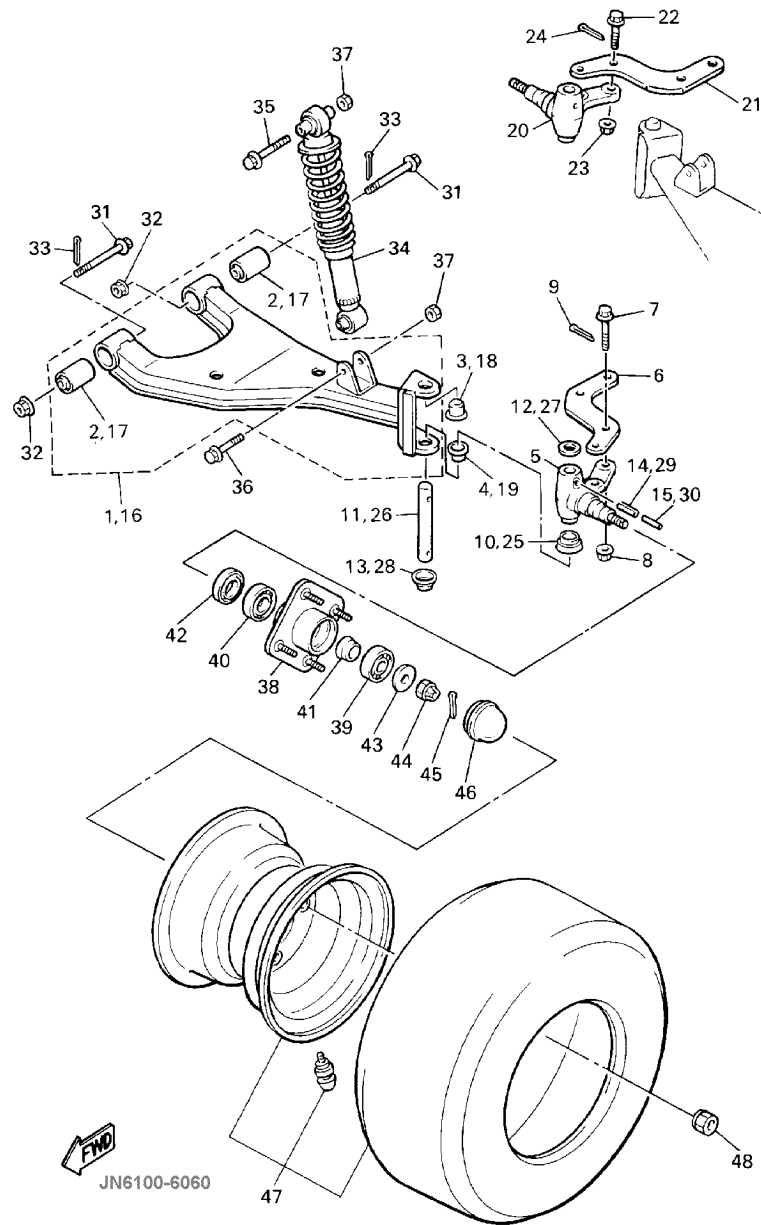

Ref. No.	Part Number	Description	Qty	Remarks
1	JN6-F3570-00-00	FRONT LOWER ARM, LEFT	1	
2	JN6-F3526-00-00	. BUSHING, ARM	1	
3	90338-17225-00	PLUG	1	
4	90386-15139-00	BUSH	1	
5	JN6-F3511-00-00	KNUCKLE, STEERING	1	
6	JN3-F3512-00-00	ARM, KNUCKLE	1	
7	90105-10360-00	BOLT, FLANGE	2	
8	95617-10200-00	NUT, SELF-LOCKING	2	
9	91490-25020-00	PIN, COTTER	2	
10	J38-23527-00-00	SEAL, DUST	1	
11	J38-23516-00-00	PIN, STEERING KNUCKLE	1	
12	90201-156J2-00	WASHER, PLAIN	1	
13	J38-23528-00-00	SEAL, DUST	1	
14	91609-60028-00	PIN, SPRING	1	
15	91609-35028-00	PIN, SPRING	1	
16	JN6-F3580-00-00	FRONT LOWER ARM, RIGHT	1	
17	JN6-F3526-00-00	. BUSHING, ARM	1	
18	90338-17225-00	PLUG	1	
19	90386-15139-00	BUSH	1	
20	JN6-F3521-00-00	KNUCKLE, STEERING	1	
21	JN3-F3512-00-00	ARM, KNUCKLE	1	
22	90105-10360-00	BOLT, FLANGE	2	
23	95617-10200-00	NUT, SELF-LOCKING	2	
24	91490-25020-00	PIN, COTTER	2	
25	J38-23527-00-00	SEAL, DUST	1	
26	J38-23516-00-00	PIN, STEERING KNUCKLE	1	
27	90201-156J2-00	WASHER, PLAIN	1	
28	J38-23528-00-00	SEAL, DUST	1	
29	91609-60028-00	PIN, SPRING	1	

CONTINUED ON NEXT FRAME ➤

# FRONT SUSPENSION - WHEEL

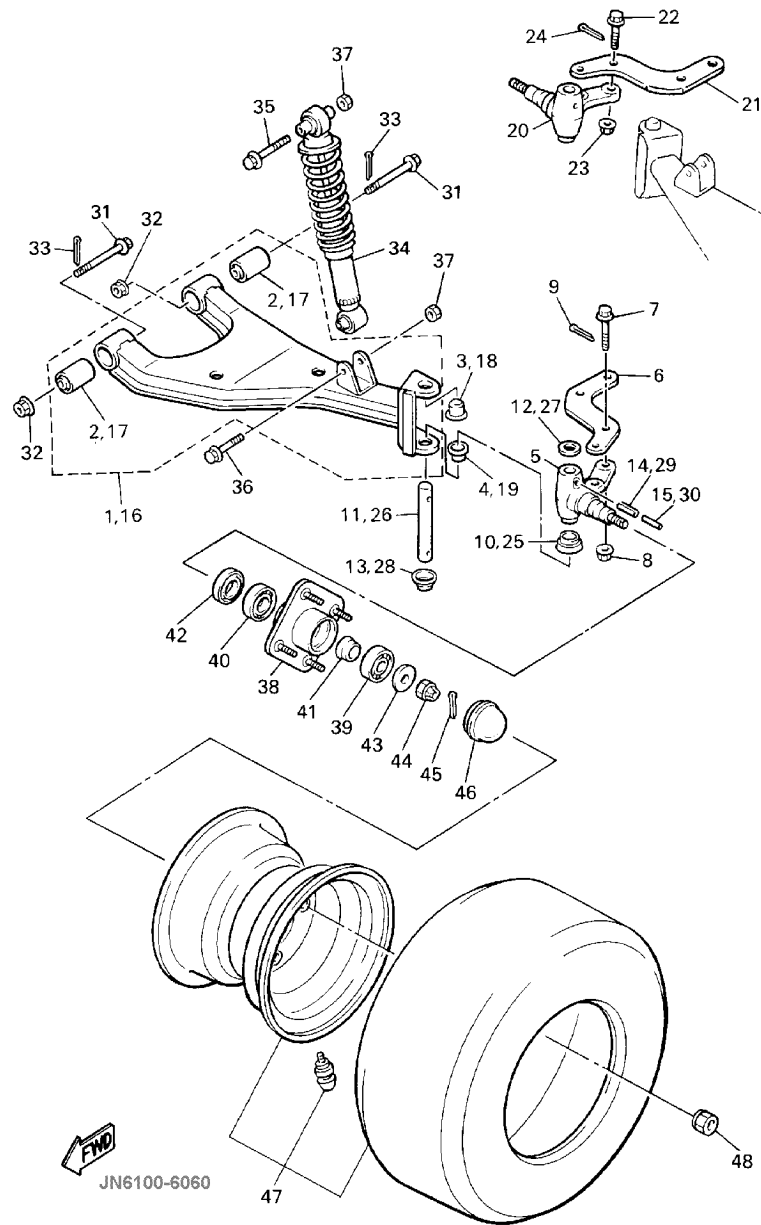

Ref. No.	Part Number	Description	Qty	Remarks
30	91609-35028-00	PIN, SPRING .....	1	
31	90105-10357-00	BOLT, FLANGE .....	4	
32	95617-10200-00	NUT, SELF-LOCKING .....	4	
33	91490-25020-00	PIN, COTTER .....	4	
34	JN3-F3350-00-00	CUSHION ASSEMBLY. ....	2	
35	95807-10065-00	BOLT, FLANGE .....	2	
36	95807-10055-00	BOLT, FLANGE .....	2	
37	95617-10200-00	NUT, SELF-LOCKING .....	4	
38	JG5-WF511-00-00	HUB .....	2	
39	93306-204X0-00	BEARING .....	2	
40	93306-005Y3-00	BEARING .....	2	
41	90387-241M7-00	COLLAR .....	2	
42	93102-30083-00	SEAL, OIL .....	2	
43	90209-32271-00	WASHER .....	2	
44	95607-14100-00	NUT, U .....	2	
45	91490-25020-00	PIN, COTTER .....	2	
46	J17-25118-00-00	COVER, HUB DUST .....	2	
47	*---	FRONT WHEEL ASSEMBLY ..	2	
48	90179-12262-00	NUT .....	8	

# STEERING

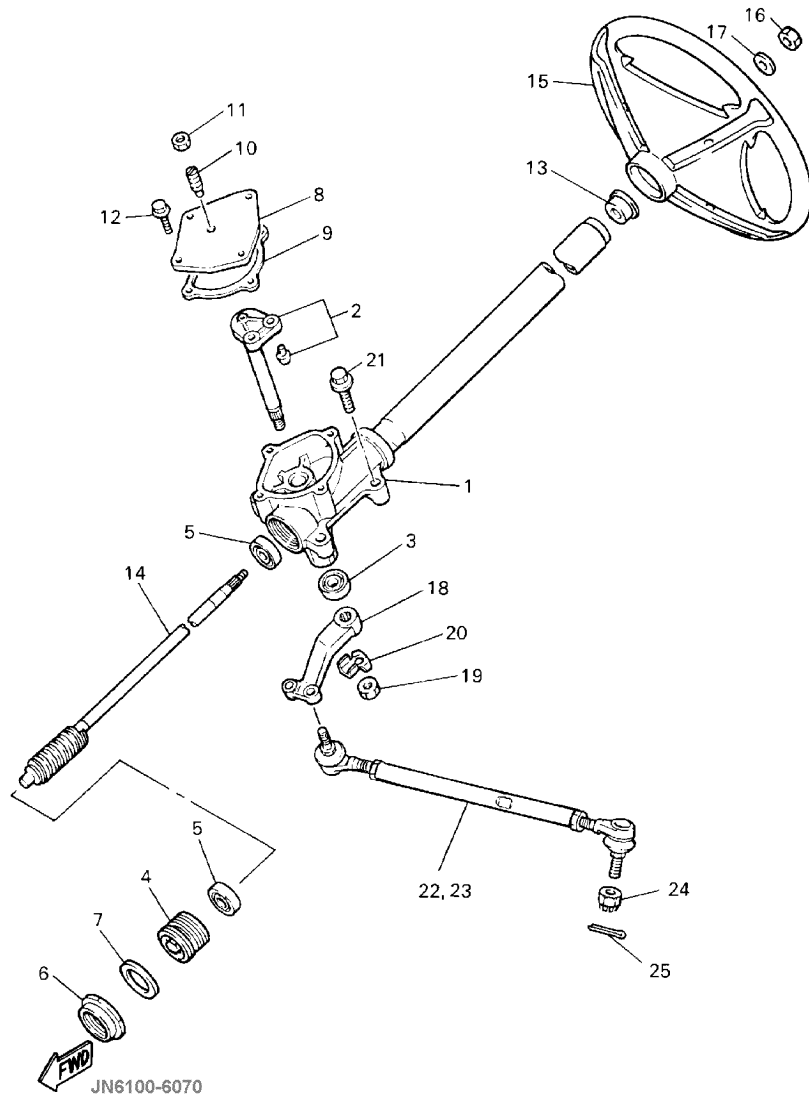

Ref. No.	Part Number	Description	Qty	Remarks
1	JG5-F3811-00-00	COLUMN, STEERING .....	1	
2	J38-23816-00-00	ARM, PITMAN .....	1	
3	93102-22314-00	SEAL, OIL .....	1	
4	J55-F3876-00-00	BOLT .....	1	
5	93332-000Y2-00	BEARING .....	2	
6	J10-23877-00-00	NUT .....	1	
7	J10-23444-00-00	WASHER .....	1	
8	JN3-F3818-00-00	COVER, STEERING .....	1	
9	J38-23462-00-00	SEAL, STEERING (J38-23462-01-00) .....	1	
10	J10-23459-00-00	BOLT .....	1	
11	90170-08024-00	NUT, HEX. ....	1	
12	95817-06020-00	BOLT, FLANGE .....	4	
13	JN3-F3814-00-00	HOLDER, HANDLE .....	1	
14	J10-23840-00-00	STEERING SHAFT .....	1	
15	JN3-F3838-00-00	WHEEL, STEERING .....	1	
16	90185-12119-00	NUT, SELF-LOCKING .....	1	
17	92907-12200-00	WASHER, PLAIN .....	1	
18	J38-23826-01-00	ARM, IDLER .....	1	
19	95707-16300-00	NUT, NYLON .....	1	
20	90215-16252-00	WASHER, TONGUE .....	1	
21	90105-100A4-00	BOLT, FLANGE .....	4	
22	JN3-F3830-00-00	TIE ROD ASSEMBLY, LEFT ...	1	
23	JN3-F3850-00-00	TIE ROD ASSEMBLY, RIGHT ..	1	
24	95617-10200-00	NUT, SELF-LOCKING .....	4	
25	91490-25020-00	PIN, COTTER .....	4	

# FUEL TANK

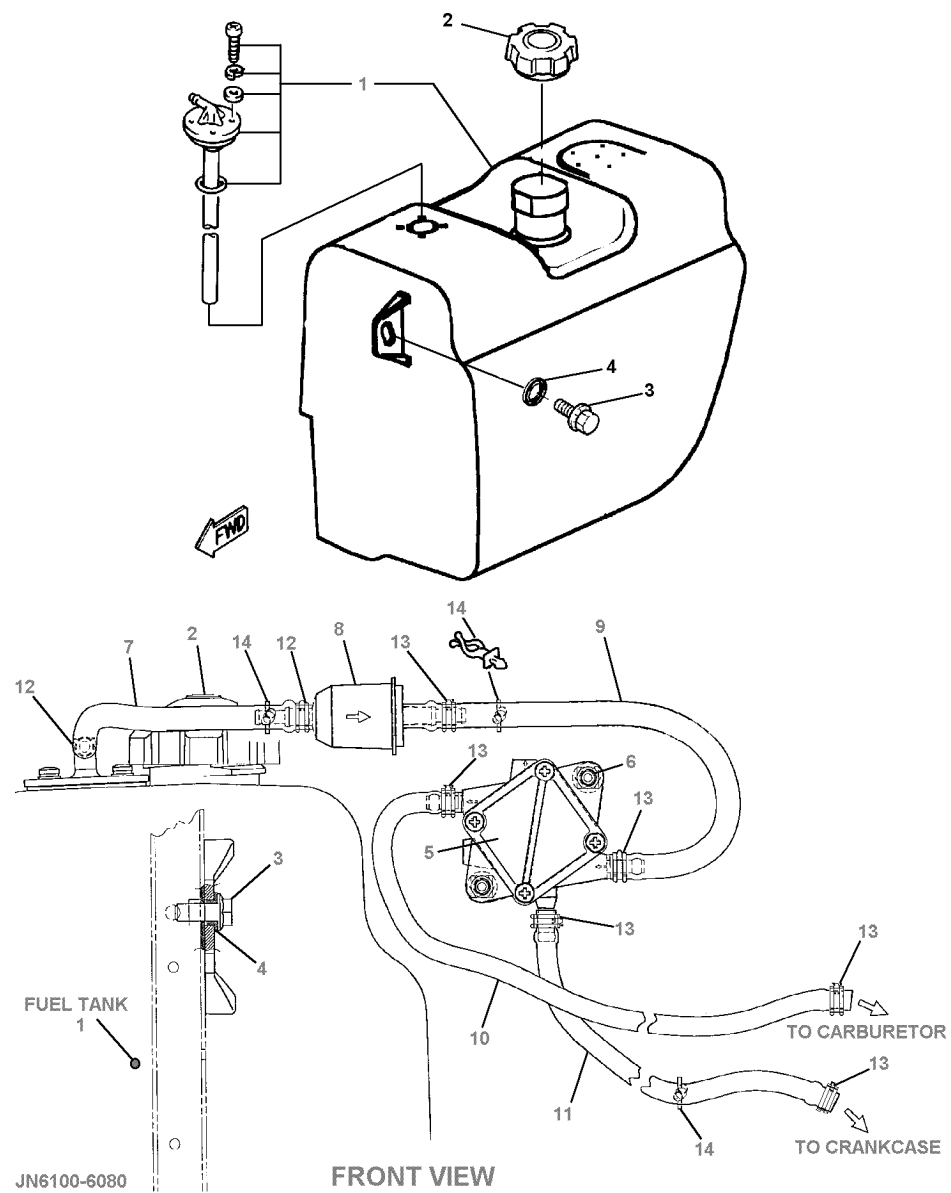

Ref. No.	Part Number	Description	Qty	Remarks
1	JN6-F4110-00-00	FUEL TANK COMP .....	1	
2	JN6-F4610-00-00	CAP ASSEMBLY. ....	1	
3	95807-08020-00	BOLT, FLANGE .....	2	
4	90560-08066-00	SPACER .....	2	
5	JN6-F4410-00-00	FUEL PUMP ASSEMBLY .....	1	
6	95817-06016-00	BOLT, FLANGE .....	2	
7	JN6-F4312-00-00	PIPE, .....	1	
8	JN3-F4560-00-00	FILTER ASSEMBLY. ....	1	
9	JN6-F4311-00-00	PIPE, FUEL .....	1	
10	JN6-F4313-00-00	PIPE, .....	1	
11	JN6-F4314-00-00	PIPE, .....	1	
12	90467-12845-00	CLIP .....	2	RED
13	90467-10846-00	CLIP .....	6	GREEN
14	90464-11816-00	CLAMP .....	3	

# BRAKE 1

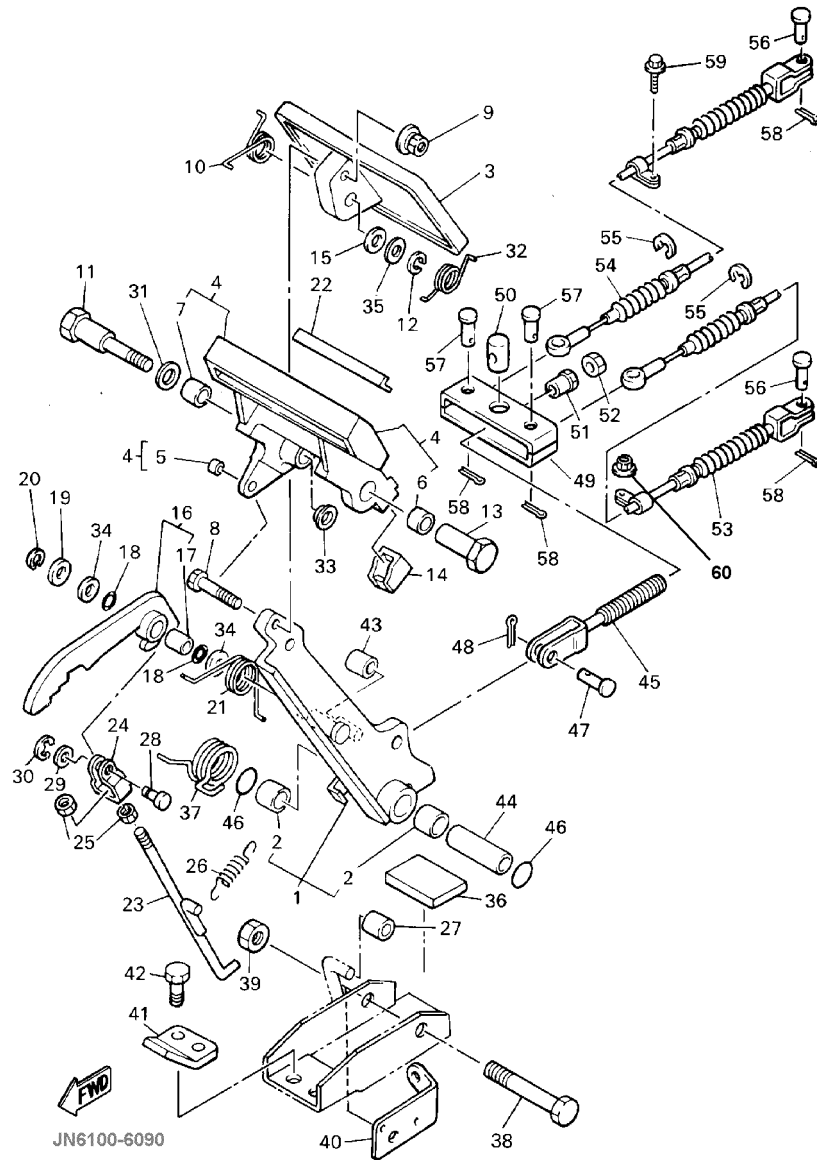

Ref. No.	Part Number	Description	Qty	Remarks
1	J46-27250-03-00	BRAKE ARM COMP	1	
2	90384-14080-00	. BUSH, BIMETAL	2	
3	J10-27211-00-00	PEDAL, BRAKE	1	
4	J17-25670-01-00	PARKING PEDAL COMP.	1	
5	90384-05163-00	. BUSH, BIMETAL	1	
6	90384-12164-00	. BUSH, BIMETAL	1	
7	90380-12051-00	. BUSH, SOLID	1	
8	90101-06555-00	BOLT, HEX.	1	
9	90179-07564-00	NUT	1	
10	90508-23542-00	SPRING, TORSION	1	
11	90109-08669-00	BOLT	1	
12	92907-08100-00	WASHER, SPRING	1	
13	90179-08378-00	NUT	1	
14	J17-25679-01-00	DAMPER	2	
15	92907-08200-00	WASHER	1	
16	J17-W2561-02-00	SECTOR, PARKING BRAKE	1	
17	90384-10162-00	. BUSH, BIMETAL	1	
18	J17-27221-00-00	SEAL, SHAFT	2	
19	92907-10600-00	WASHER, PLATE	1	
20	99080-07600-00	CIRCLIP (E)	1	
21	90508-14548-00	SPRING, TORSION	1	
22	J17-25672-01-00	PAD, PARKING	1	
23	J17-27231-03-00	ROD, BRAKE	1	
24	J17-27232-00-00	END, ROD	1	
25	95317-06700-00	NUT	2	
26	90506-12277-00	SPRING, TENSION	1	
27	J17-25673-00-00	DAMPER, BRAKE	1	
28	J17-27228-00-00	PIN, LINK JOINT	1	
29	92907-05600-00	WASHER, PLATE	1	

CONTINUED ON NEXT FRAME ►

# BRAKE 1

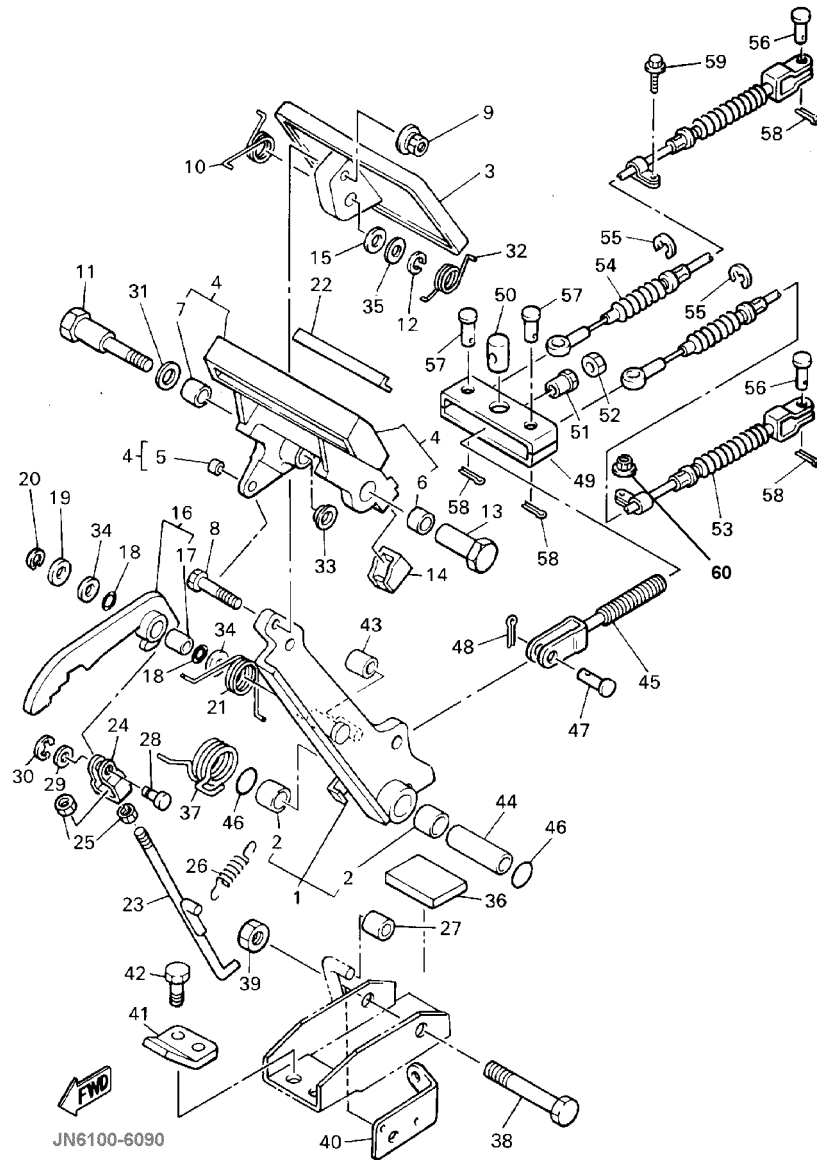

Ref. No.	Part Number	Description	Qty	Remarks
30	99080-04600-00	CIRCLIP (E)	1	
31	90201-123F2-00	WASHER, PLAIN	1	
32	90508-26557-00	SPRING, TORSION	1	
33	90380-12105-00	BUSH, SOLID	1	
34	90201-104G8-00	WASHER, PLAIN	2	
35	J55-27226-00-00	WASHER, LINK	1	
36	JN3-F7245-00-00	PAD, BRAKE PEDAL	1	
37	90508-405A9-00	SPRING, TORSION	1	
38	90101-10447-00	BOLT, HEX.	1	
39	95617-10200-00	NUT, SELF-LOCKING	1	
40	J55-2252M-00-00	BRACKET,	1	
41	J17-27246-00-00	NAIL, BRAKE	1	
42	95807-08020-00	BOLT, FLANGE	2	
43	J17-25673-00-00	DAMPER, BRAKE	1	
44	90387-107F8-00	COLLAR	1	
45	JN6-F5685-00-00	ROD	1	
46	93210-132A8-00	O-RING	2	
47	91701-10022-00	PIN	1	
48	91490-30020-00	PIN, COTTER	1	
49	JN6-F5681-00-00	EQUALIZER, BRAKE	1	
50	90249-14129-00	PIN	1	
51	90179-08261-00	NUT	1	
52	95317-08700-00	NUT	1	
53	JN6-F6341-00-00	WIRE, BRAKE	1	
54	JF2-F6351-10-00	WIRE, BRAKE	1	
55	99001-09600-00	CIRCLIP	4	
56	91701-08018-00	PIN	2	
57	91701-08026-00	PIN	2	
58	91490-25020-00	PIN, COTTER	4	

CONTINUED ON NEXT FRAME ►

# BRAKE 1

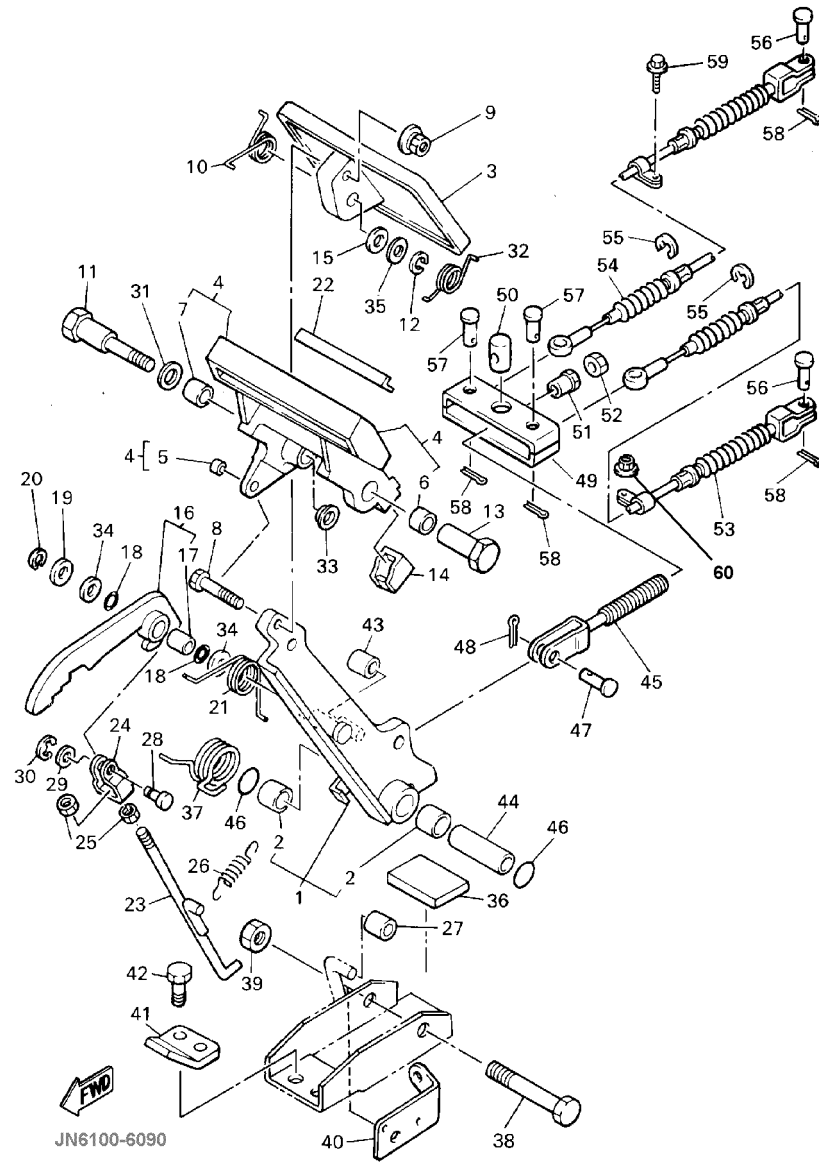

Ref. No.	Part Number	Description	Qty	Remarks
59	95817-06016-00	BOLT, FLANGE .....	2	
60	95617-08200-00	NUT, SELF-LOCKING (95607-08200-00) .....	1	

# BRAKE 2

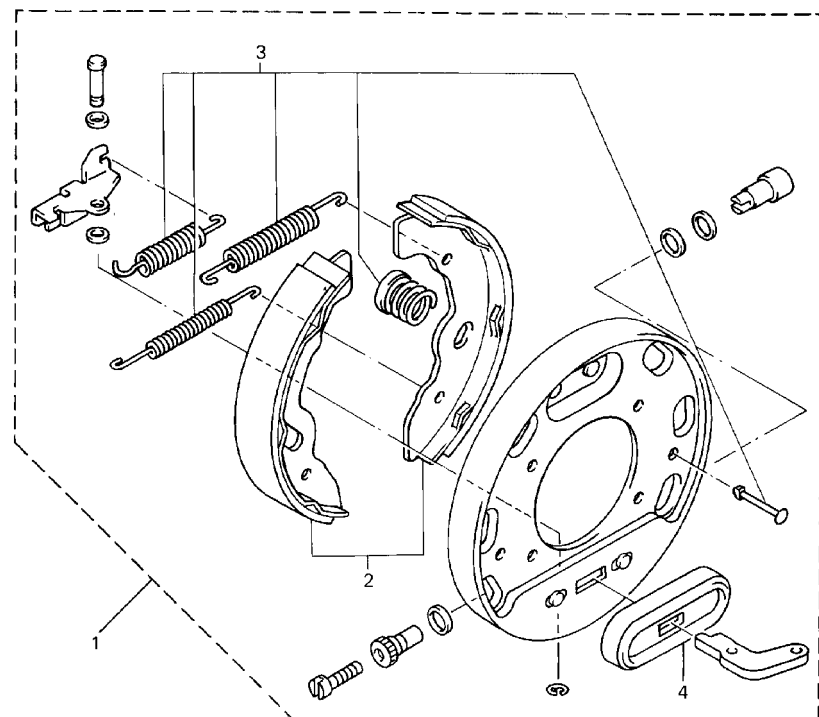

Ref. No.	Part Number	Description	Qty	Remarks
1	JN3-F7280-00-00	BACKING PLATE, (RH)	1	FOR RIGHT WHEEL ONLY
2	JN3-F5340-00-00	. SHOE, BRAKE SET	1	
3	JG5-F819G-00-00	. REPAIR PARTS KIT	1	
4	JG5-F7286-00-00	. COVER, DUST	1	



JN4100-5060

## BRAKE 3

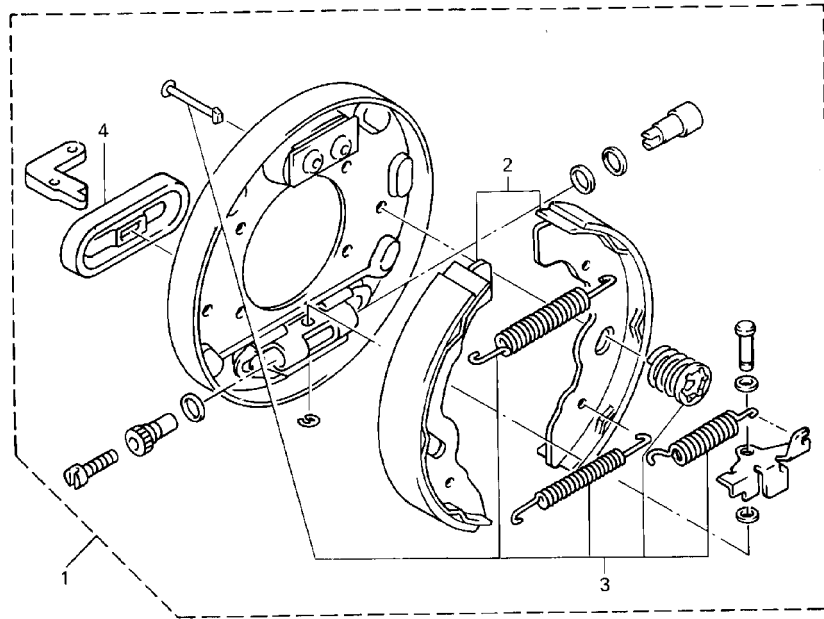

Ref. No.	Part Number	Description	Qty	Remarks
1	JN3-F7290-00-00	BACKING PLATE, LEFT	1	FOR LEFT WHEEL ONLY
2	JN3-F5330-00-00	. SHOE, BRAKE SET	1	
3	JG5-F819G-00-00	. REPAIR PARTS KIT	1	
4	JG5-F7286-00-00	. COVER, DUST	1	



JN4100-5070

# ACCELERATOR

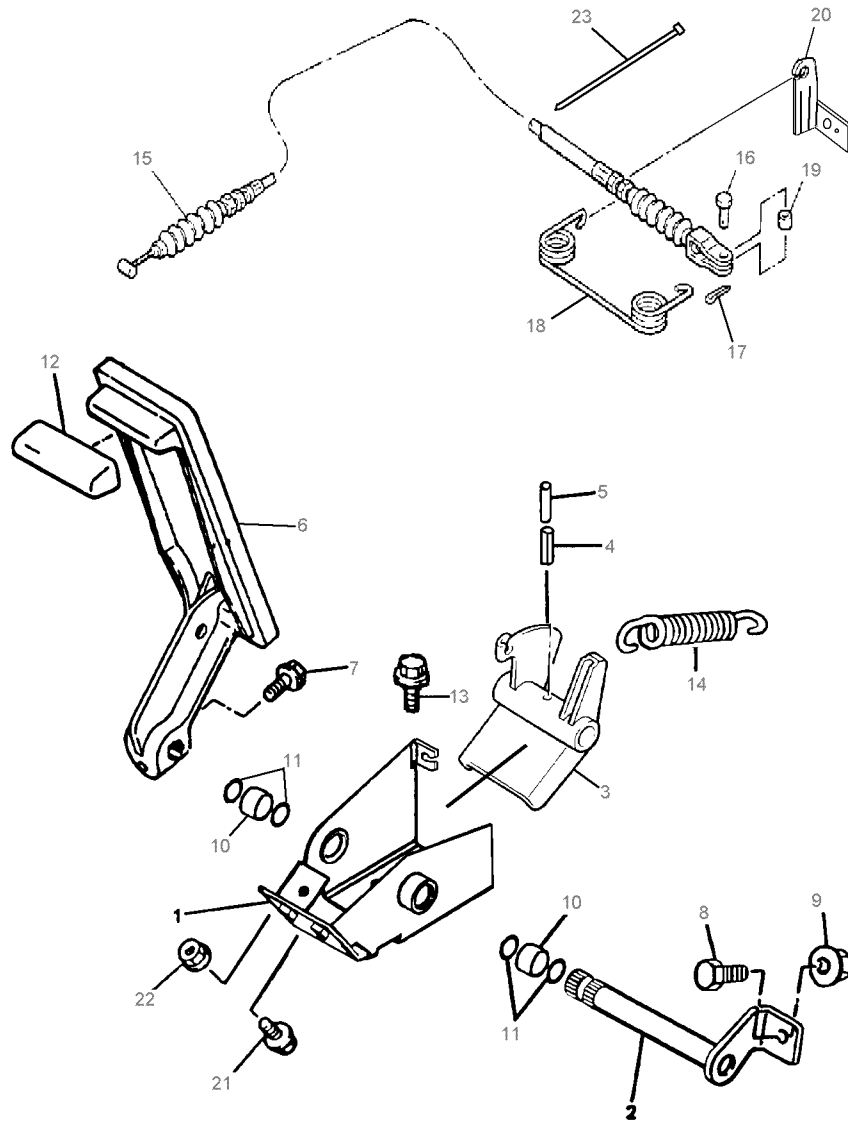

Ref. No.	Part Number	Description	Qty	Remarks
1	JN6-F7874-00-00	BRACKET, PEDAL .....	1	
2	J17-27853-01-00	SHAFT, PEDAL .....	1	
3	J38-27872-00-00	ARM, ACCELERATOR .....	1	
4	91609-60028-00	PIN, SPRING .....	1	
5	91609-35028-00	PIN, SPRING .....	1	
6	JF3-27871-00-00	PEDAL, ACCELERATOR .....	1	
7	95817-06025-00	BOLT, FLANGE .....	1	
8	90106-08040-00	BOLT, RD. HEX .....	1	
9	95707-08500-00	NUT, FLANGE .....	1	
10	90384-14080-00	BUSH, BIMETAL .....	2	
11	93210-14104-00	O-RING .....	4	
12	JN3-F7854-00-00	COVER, PEDAL .....	1	
13	95817-08016-00	BOLT, FLANGE .....	3	
14	90506-26282-00	SPRING, TENSION .....	1	
15	JN3-F6311-00-00	WIRE, THROTTLE .....	1	
16	91702-05012-00	PIN .....	1	
17	90468-10050-00	CLIP .....	1	
18	90508-16460-00	SPRING, TORSION .....	1	
19	90560-05001-00	SPACER .....	1	
20	JN3-G6556-00-00	BRACKET, .....	1	
21	95817-06025-00	BOLT, FLANGE .....	1	
22	95707-06500-00	NUT, FLANGE .....	1	
23	90601-200U1-00	BAND .....	2	



JN6100-6120

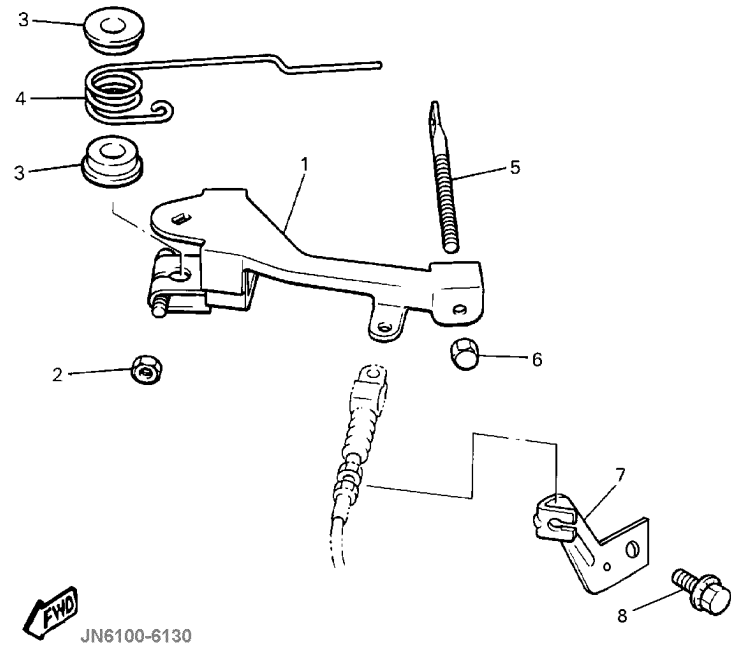

# GOVERNOR

Ref. No.	Part Number	Description	Qty	Remarks
1	J38-27951-00-00	LEVER, SPEED .....	1	
2	95317-06600-00	NUT (95307-06600-00) .....	1	
3	90386-08141-00	BUSH .....	2	
4	90508-40678-00	SPRING, TORSION .....	1	
5	J38-27959-00-00	SCREW, ADJUSTING .....	1	
6	95607-06200-00	NUT, SELF U-FLANGE .....	1	
7	JN3-G6555-00-00	BRACKET .....	1	
8	90105-08859-00	BOLT, FLANGE .....	1	

# PRIMARY CLUTCH

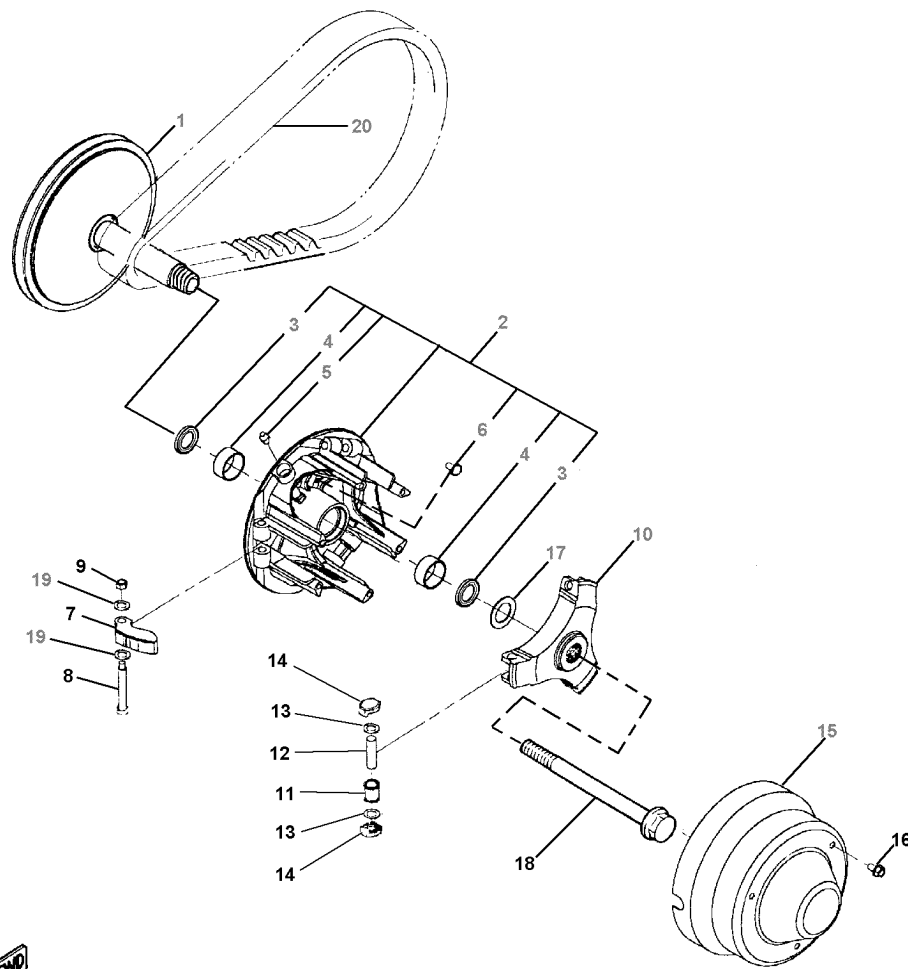

Ref. No.	Part Number	Description	Qty	Remarks
1	JN6-G6210-00-00	PRIMARY FIXED SHEAVE	1	
2	JN6-G6220-00-00	PRIMARY SLIDING SHEAVE	1	
3	93101-28831-00	. SEAL, OIL	2	
4	90384-27823-00	. BUSH, BIMETAL	2	
5	93700-06810-00	. NIPPLE, GREASE	1	
6	90338-04840-00	. PLUG	3	
7	JN6-G6232-00-00	WEIGHT,	3	
8	90109-06860-00	BOLT	3	
9	90185-06834-00	NUT, SELF-LOCKING	3	
10	JN6-G6251-00-00	SPIDER	1	
11	JN6-G6258-00-00	COLLAR, ROLLER	3	
12	93610-358A3-00	PIN, DOWEL	3	
13	90201-098J1-00	WASHER, PLAIN	6	
14	JN6-G6253-00-00	SLIDER	6	
15	JN6-G6231-00-00	CAP	1	
16	90105-06861-00	BOLT, FLANGE	3	
17	90201-228K5-00	WASHER, PLAIN	1	
18	JN6-G6249-00-00	BOLT	1	
19	JN6-G621F-00-00	SHIM, THRUST	6	
20	J55-G6241-00-00	BELT	1	

FWD  
JN6100-6140

# SECONDARY SHEAVE

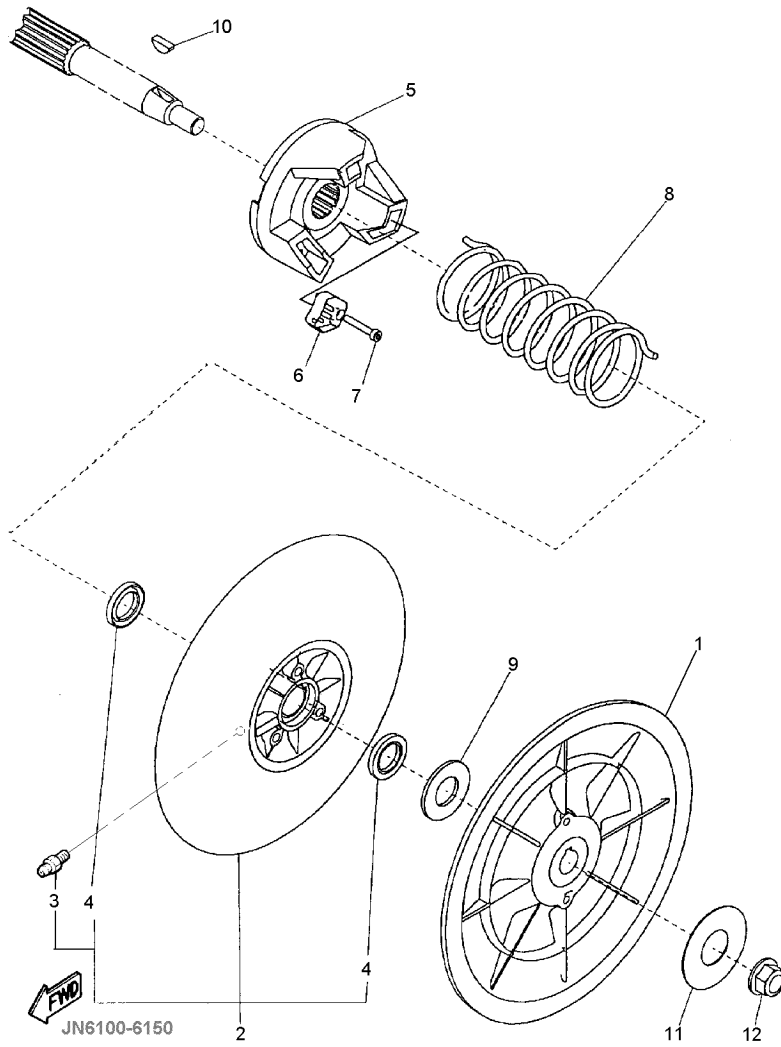

Ref. No.	Part Number	Description	Qty	Remarks
1	JN6-G6260-00-00	SECONDARY FIXED SHEAVE .	1	
2	JN6-G6270-00-00	SECONDARY SLIDING SHEAVE	1	
3	93700-06809-00	. NIPPLE, GREASE . . . . .	1	
4	93102-20309-00	. SEAL, OIL . . . . .	2	
5	JN6-G6280-00-00	SECONDARY SPRING SEAT ..	1	
6	JN6-E7688-00-00	. SHOE, RAMP . . . . .	3	
7	90110-04834-00	. BOLT, HEX. SOCKET . . . . .	3	
8	90508-45844-00	SPRING, TORSION . . . . .	1	L=100.5
9	90202-20130-00	WASHER, PLAIN . . . . .	1	
10	90280-05022-00	KEY, WOODRUFF . . . . .	1	
11	90201-12588-00	WASHER, PLATE . . . . .	1	
12	95617-12200-00	NUT, SELF-LOCKING . . . . .	1	

# TRANSMISSION 1

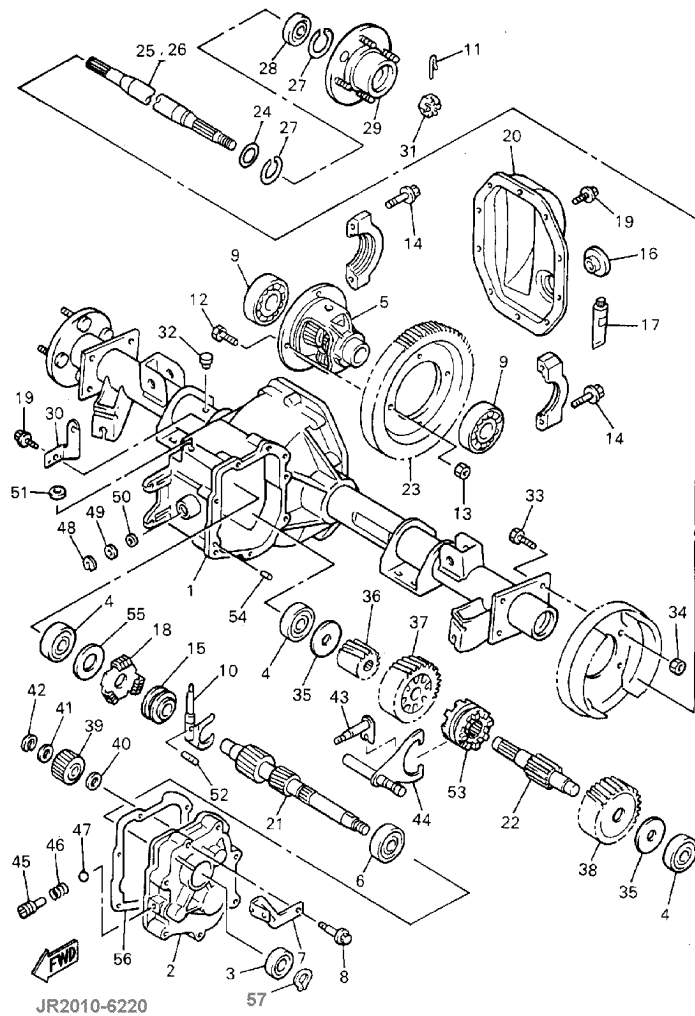

Ref. No.	Part Number	Description	Qty	Remarks
1	JN3-G6290-00-00	CASE ASSEMBLY .....	1	
2	JN3-G6313-00-00	COVER, TRANSMISSION .....	1	
3	93102-25868-00	SEAL, OIL .....	1	
4	93306-303Y6-00	BEARING .....	3	
5	JN3-G6410-00-00	DIFFERENTIAL ASSEMBLY. ..	1	
6	93306-005Y4-00	BEARING .....	1	
7	JN6-G6555-00-00	BRACKET, .....	1	
8	90105-08859-00	BOLT, FLANGE .....	7	
9	93306-007Y0-00	BEARING .....	2	
10	JN3-G633E-00-00	BAR, .....	1	
11	91490-25030-00	PIN, COTTER .....	2	
12	90101-10854-00	BOLT, HEX. ....	4	
13	90170-10840-00	NUT, HEX. ....	4	
14	90105-10840-00	BOLT, FLANGE .....	4	
15	JN3-G6368-00-00	COLLAR, IDLER .....	1	
16	JN3-G6432-00-00	STOPPER .....	1	
17	ACC-QUICK-GS-KT	SEALANT .....	1	JH7-G6136-00
18	JN3-G6336-00-00	PLATE, 1 .....	1	
19	90101-08856-00	BOLT, HEX. ....	11	
20	JN3-G6314-00-00	COVER, TRANSMISSION .....	1	
21	JN3-G6321-00-00	SHAFT, INPUT .....	1	
22	JN3-G633G-00-00	SHAFT .....	1	
23	JN3-G6355-00-00	GEAR, PRIMARY .....	1	
24	93101-24822-00	SEAL, OIL .....	2	
25	JN3-G6511-00-00	SHAFT, RR. AXLE .....	1	
26	JN3-G6512-00-00	SHAFT, RR. AXLE .....	1	
27	93420-44805-00	CIRCLIP .....	4	
28	93306-004X5-00	BEARING .....	2	
29	JN3-G6514-00-00	HUB, RR. AXLE .....	2	

CONTINUED ON NEXT FRAME ►

# TRANSMISSION 1

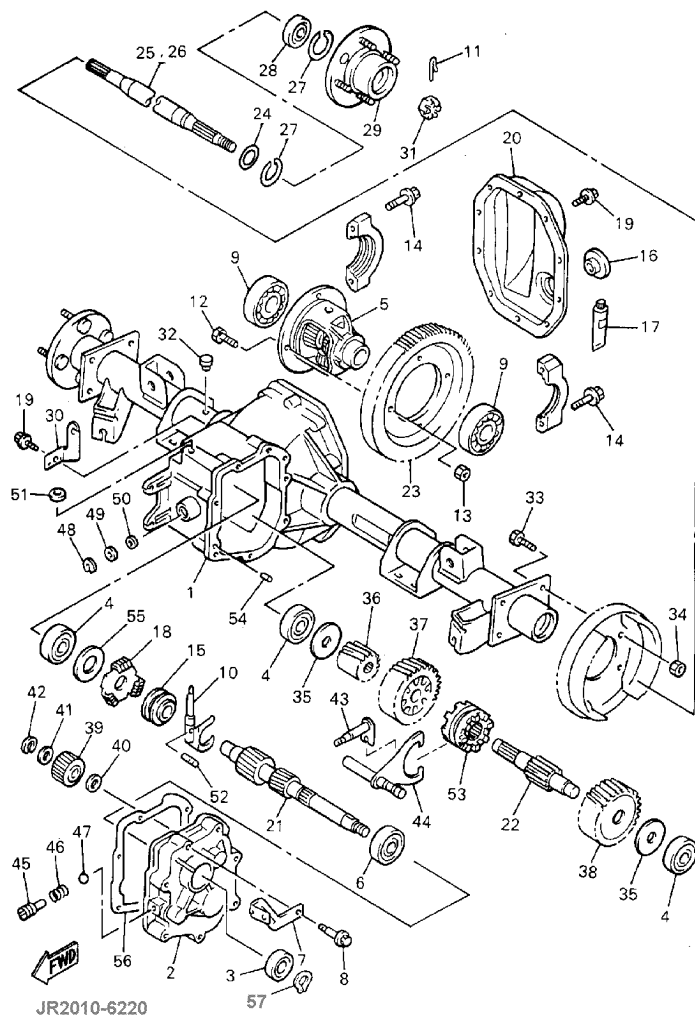

Ref. No.	Part Number	Description	Qty	Remarks
30	JN3-G6556-00-00	BRACKET, .....	1	
31	90185-16833-00	NUT, SELF-LOCKING .....	2	
32	JH7-G5619-00-00	CAP .....	1	
33	90101-08855-00	BOLT, HEX. ....	8	
34	90170-08841-00	NUT, HEX. ....	8	
35	90201-178H8-00	WASHER, PLAIN .....	2	
36	JN3-G6316-00-00	GEAR, PINION .....	1	
37	JN3-G6326-00-00	GEAR, WHEEL .....	1	
38	JN3-G6327-00-00	GEAR, WHEEL .....	1	
39	JN3-G6356-00-00	GEAR, IDLER .....	1	
40	90201-208H9-00	WASHER, PLAIN .....	1	
41	90201-208J0-00	WASHER, PLAIN .....	1	
42	93440-20813-00	CIRCLIP .....	1	
43	JN3-G638A-00-00	BAR, SHIFT .....	1	
44	JN3-G638E-00-00	BAR, SHIFT .....	1	
45	90113-08803-00	BOLT, SET .....	1	
46	90501-10852-00	SPRING, COMPRESSION .....	1	
47	93500-06826-00	BALL .....	1	
49	90202-12807-00	WASHER, PLAIN .....	1	
50	93104-11829-00	SEAL, OIL .....	1	
51	93104-09828-00	SEAL, OIL .....	1	
52	JN3-G6249-00-00	BOLT .....	1	
53	JN3-G6153-00-00	COLLAR, GUIDE .....	1	
54	93606-10842-00	PIN, DOWEL .....	2	
55	JN3-G6344-00-00	SHIM .....	1	0.76 (0.030)
	JN3-G6344-10-00	SHIM .....	1	0.90 (0.035)
	JN3-G6344-20-00	SHIM .....	1	1.0ä (0.040)
	JN3-G6344-30-00	SHIM .....	1	1.14 (0.045)
	JN3-G6344-40-00	SHIM .....	1	1.27 (0.050)

CONTINUED ON NEXT FRAME ►

# TRANSMISSION 1

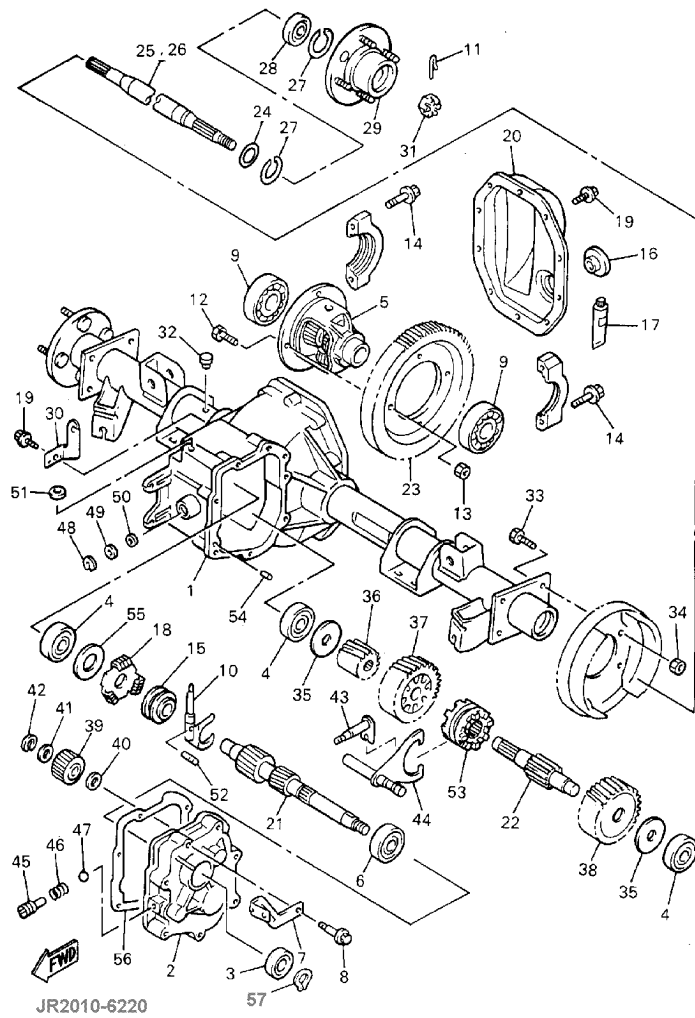

Ref. No.	Part Number	Description	Qty	Remarks
55	JN3-G6344-50-00	SHIM .....	1	1.39 (0.055)
	JN3-G6344-60-00	SHIM .....	1	1.52 (0.060)
	JN3-G6344-70-00	SHIM .....	1	1.65 (0.065)
	JN3-G6344-80-00	SHIM .....	1	0.38 (0.015)
56	JN3-G6319-00-00	GASKET .....	1	
57	93410-25017-00	CIRCLIP .....	1	

# REAR AXLE - WHEEL

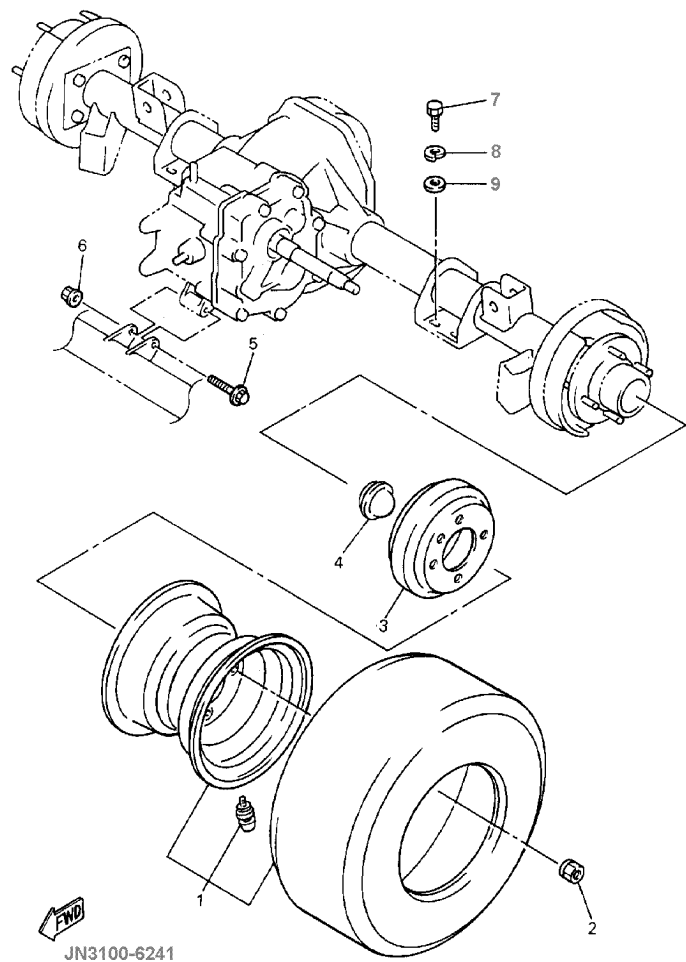

Ref. No.	Part Number	Description	Qty	Remarks
1	*---	FRONT WHEEL ASSEMBLY	2	
2	90179-12262-00	NUT	8	
3	J55-G6521-00-00	DRUM	2	
4	J17-25118-00-00	COVER, HUB DUST	2	
5	95817-08075-00	BOLT, FLANGE	1	
6	95707-08500-00	NUT, FLANGE	1	
7	97017-10020-00	BOLT	8	
8	92907-10100-00	WASHER, SPRING	8	
9	90201-102G9-00	WASHER, PLATE	8	

# SHIFTER - CABLES

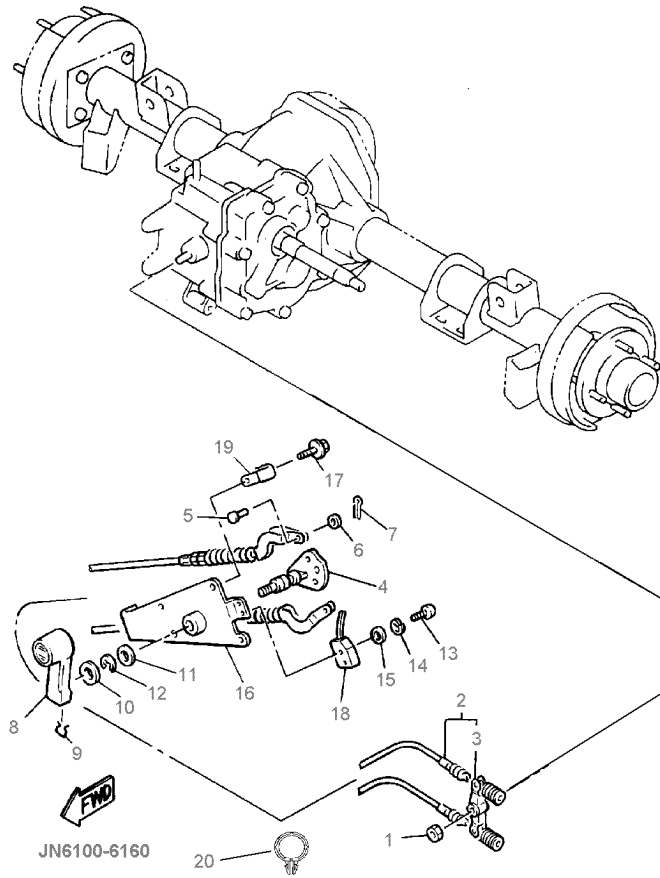

Ref. No.	Part Number	Description	Qty	Remarks
1	95617-08100-00	NUT, U .....	1	
2	JN3-G8330-00-00	CABLE, SHIFT .....	2	
3	J55-G6383-00-00	LEVER, SHIFT .....	1	
4	JF2-46382-00-00	LEVER, SHIFT .....	1	
5	91702-06014-00	PIN .....	2	
6	92907-06600-00	WASHER, PLATE .....	2	
7	91490-20025-00	PIN, SPLIT .....	2	
8	JN3-G6381-00-00	KNOB, SHIFT .....	1	
9	JN3-G6376-00-00	SPRING SET .....	1	
10	90201-201L9-00	WASHER, PLAIN .....	1	
11	90201-19551-00	WASHER, PLAIN .....	1	
12	99009-19400-00	CIRCLIP .....	1	
13	98507-04016-00	SCREW, PAN HEAD .....	2	
14	92907-04100-00	WASHER, SPRING .....	2	
15	92907-04600-00	WASHER .....	2	
16	JN3-G6372-00-00	BRACKET, SHIFT .....	1	
17	95817-06016-00	BOLT, FLANGE .....	4	
18	JN3-82617-00-00	SWITCH .....	1	
19	90465-06038-00	CLAMP .....	1	
20	90464-19815-00	CLAMP .....	1	

# BUMPER

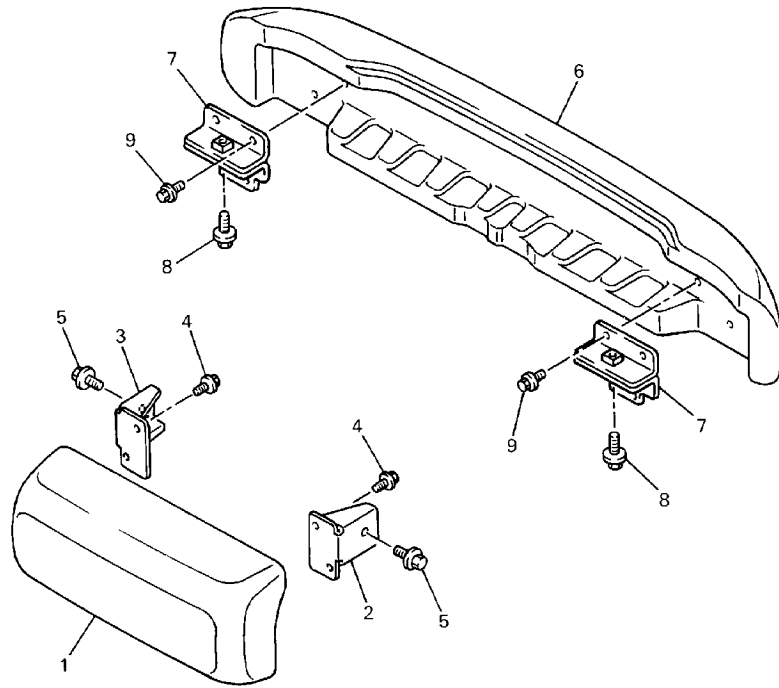

Ref. No.	Part Number	Description	Qty	Remarks
1	JN3-K7510-00-00	FRONT BUMPER COMP. ....	1	
2	JN3-K8164-00-00	STAY, FR. BUMPER .....	1	
3	JN3-K8165-00-00	STAY, FR. BUMPER .....	1	
4	95817-06016-00	BOLT, FLANGE .....	4	
5	95817-08016-00	BOLT, FLANGE .....	2	
6	JN3-K7540-00-00	REAR BUMPER .....	1	
7	JN3-K8174-00-00	STAY, RR. BUMPER .....	2	
8	95817-10020-00	BOLT, FLANGE .....	2	
9	95817-06016-00	BOLT, FLANGE .....	4	

 JN6100-6170

# BODY 1

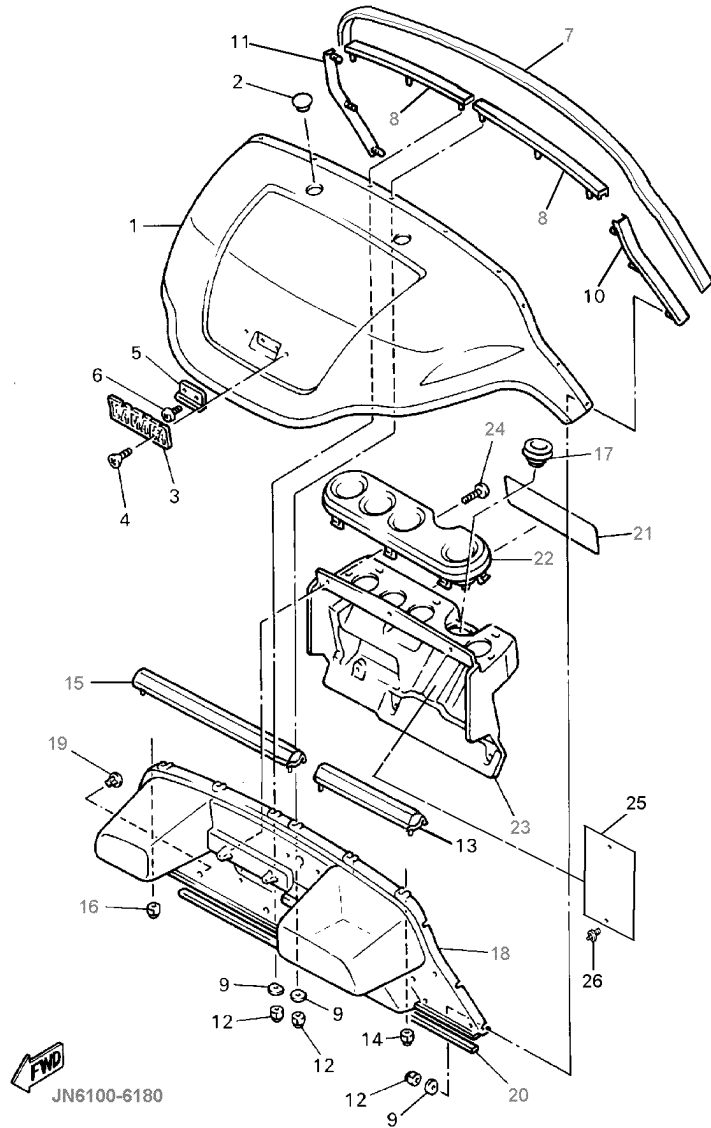

Ref. No.	Part Number	Description	Qty	Remarks
1	JN3-K8115-00-00	COWL, FRONT .....	1	IVORY WHITE (09E)
	JN3-K8115-10-00	COWL, FRONT .....	1	SUNFEST RED (391)
	JN3-K8115-20-00	COWL, FRONT .....	1	KINGSTON GRAY (483)
	JN3-K8115-30-00	COWL, FRONT .....	1	COASTA TEAL (519)
2	JN3-K818E-00-00	CAP, PROTECTOR .....	2	
3	JN6-F4161-00-00	EMBLEM, .....	1	
4	90162-04002-00	SCREW, OVAL C .....	2	
5	JF2-K811G-00-00	BOLT, COWL FITTING .....	1	
6	98980-06016-00	SCREW, BINDING .....	2	
7	JF2-K811V-00-00	PROTECTOR, .....	1	
8	JF2-K8261-00-00	PLATE, BODY PROTECTOR ..	2	
9	JN3-K8117-00-00	PLATE, .....	12	
10	JF2-K8262-00-00	PLATE, BODY PROTECTOR ..	1	
11	JF2-K8263-00-00	PLATE, BODY PROTECTOR ..	1	
12	90185-06836-00	NUT, SELF LOCKING .....	12	
13	JN6-K8264-00-00	PLATE, BODY PROTECTOR ..	1	
14	95607-06200-00	NUT, SELF U-FLANGE .....	2	
15	JN6-K8265-00-00	PLATE, BODY PROTECTOR ..	1	
16	95607-06200-00	NUT, SELF U-FLANGE .....	2	
17	JN3-K8273-00-00	COVER, HOLE .....	1	
18	JF2-K8114-02-00	PANEL, FRONT .....	1	
19	90269-08069-00	RIVET .....	3	
20	JN3-K815G-00-00	SEAL, FRONT STORAGE ....	1	
21	JN3-K7768-00-00	LABEL, WARNING .....	1	UR
22	JN3-K835E-00-00	HOLDER, BEVERAGE .....	1	
23	JN3-K835G-00-00	HOUSING, HOLDER .....	1	
24	97707-60130-00	SCREW, PAN HEAD .....	6	
25	JN6-K8182-00-00	PLATE, .....	1	

CONTINUED ON NEXT FRAME ►

# BODY 1

Ref. No.	Part Number	Description	Qty	Remarks
26	90267-63047-00	RIVET, BLIND .....	2	

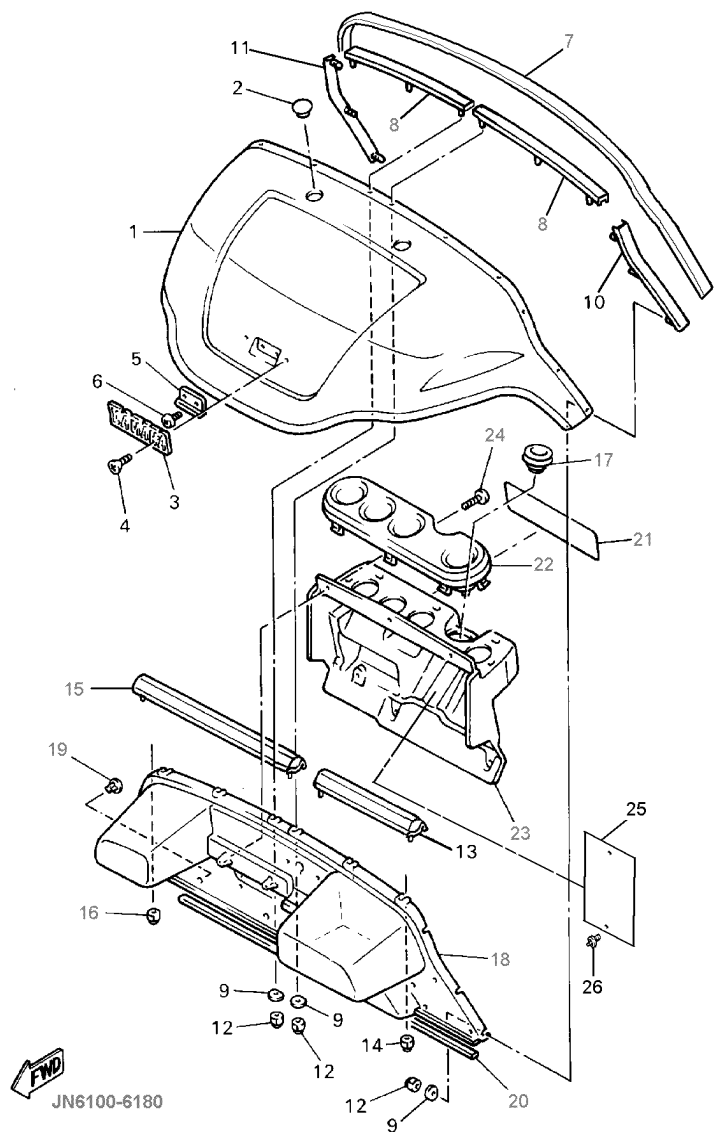

## BODY 2

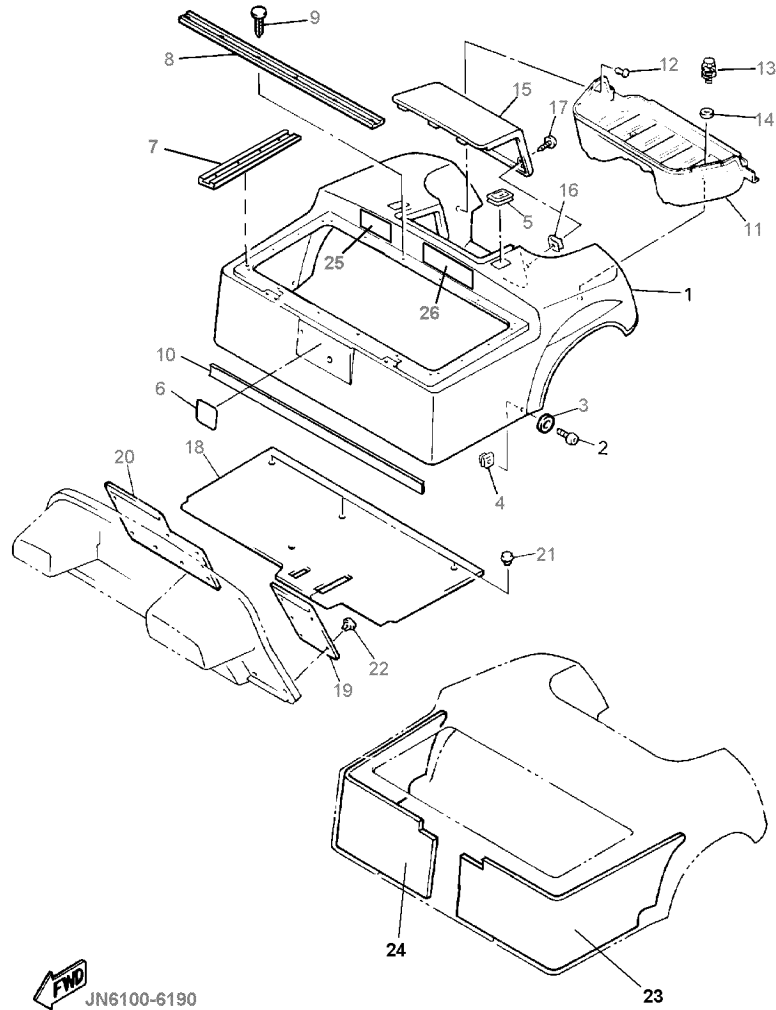

Ref. No.	Part Number	Description	Qty	Remarks
1	JN6-K8142-00-00	PANEL, REAR BODY .....	1	IVORY WHITE (09E)
	JN6-K8142-10-00	PANEL, REAR BODY .....	1	SUNFEST RED (391)
	JN6-K8142-20-00	PANEL, REAR BODY .....	1	KINGSTON GRAY (483)
	JN6-K8142-30-00	PANEL, REAR BODY .....	1	COASTA TEAL (519)
2	90110-06200-00	BOLT, HEXAGON SOCKET HEAD .....	2	
3	90201-068H0-00	WASHER, PLAIN .....	2	
4	90183-06811-00	NUT, SPRING .....	2	
5	JN3-K8363-00-00	PROTECTOR .....	2	
6	JN3-K7741-00-00	INDICATOR, .....	1	
7	JN3-K8425-00-00	SEAL, SEAT .....	2	
8	JN3-K842A-00-00	SEAL, SEAT .....	2	
9	90338-05834-00	PLUG .....	20	
10	JN6-K824E-00-00	TRIM, REAR BODY .....	1	
11	JF2-K8237-00-00	COVER, REAR FLOOR .....	1	
12	90269-08069-00	RIVET .....	7	
13	90119-06823-00	BOLT, HEX. W/WASHER .....	2	
14	90201-068G7-00	WASHER, PLAIN .....	2	
15	JN3-K8151-00-00	PANEL, INSPECTION .....	1	
16	90183-06035-00	NUT, SPRING .....	2	
17	90160-05805-00	SCREW, ROUND TAPPING ...	2	
18	JN6-K8233-00-00	MAT, MAIN FLOOR 3 .....	1	
19	JN6-K8231-00-00	MAT, MAIN FLOOR .....	1	
20	JN6-K8232-00-00	MAT, MAIN FLOOR .....	1	
21	90269-08813-00	RIVET .....	4	
22	90267-63047-00	RIVET, BLIND .....	10	
23	JN6-K8251-00-00	PAD, SILENCER .....	1	
24	JN6-K8252-00-00	PAD, SILENCER .....	1	

CONTINUED ON NEXT FRAME ►

# BODY 2

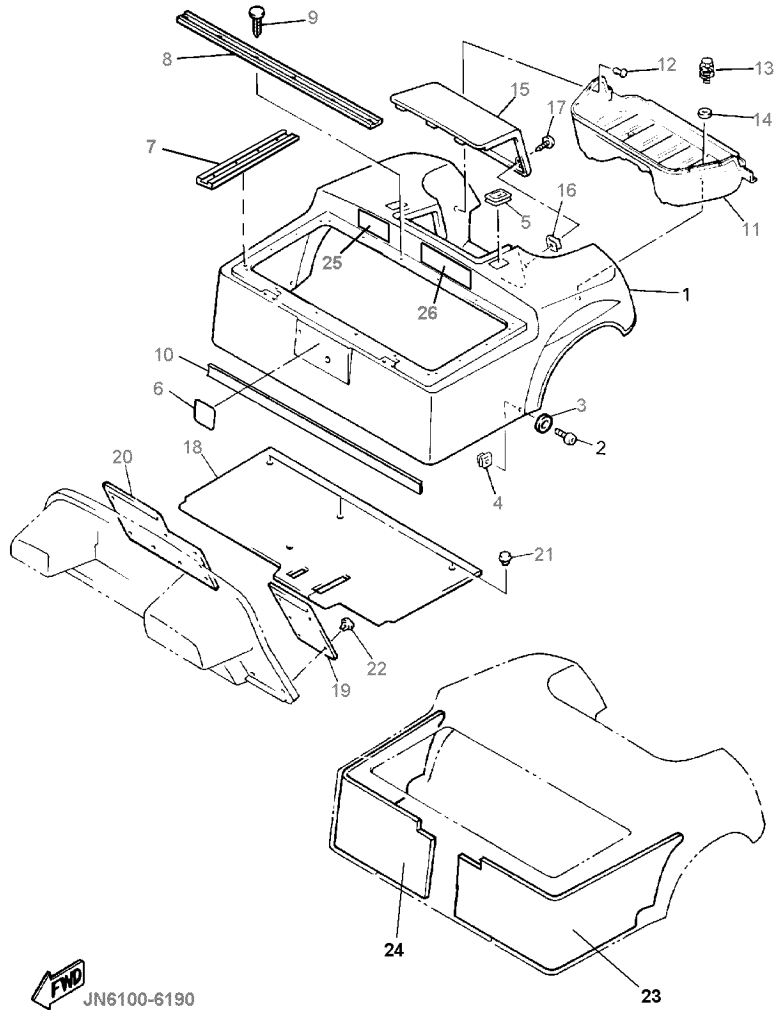

Ref. No.	Part Number	Description	Qty	Remarks
25	JN3-K8297-00-00	PLATE, CAUTION .....	1	
26	JN3-K8299-00-00	PLATE, CAUTION .....	1	

## BODY FITTING

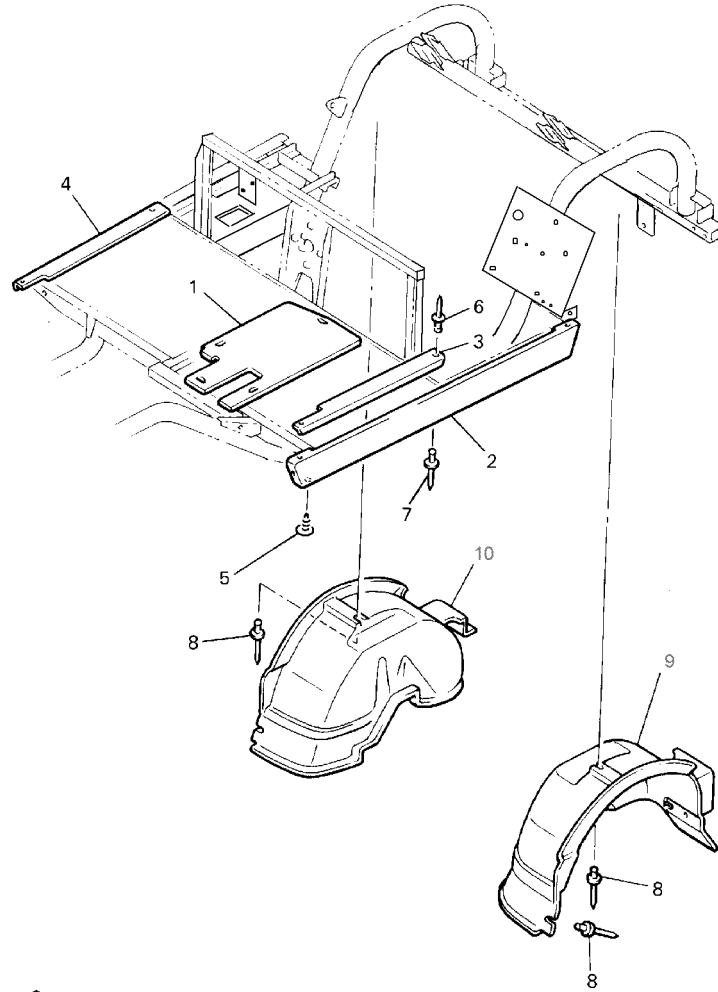

Ref. No.	Part Number	Description	Qty	Remarks
1	JN6-K8271-00-00	SERVICE LID .....	1	
2	JF2-K818A-00-00	PROTECTOR, SIDE .....	2	
3	JF2-K8215-10-00	PLATE, SIDE TRIM .....	1	
4	JF2-K821F-10-00	PLATE, SIDE TRIM .....	1	
5	90338-05829-00	PLUG .....	6	
6	90267-48154-00	RIVET, BLIND .....	4	
7	90267-48831-00	RIVET, BLIND (90267-48101-00) .....	4	
8	90267-48086-00	RIVET, BLIND .....	4	
9	JF2-K8191-00-00	PANEL, REAR FENDER .....	1	
10	JF2-K8192-00-00	PANEL, REAR FENDER .....	1	

 JN6100-6200

# CARRIER

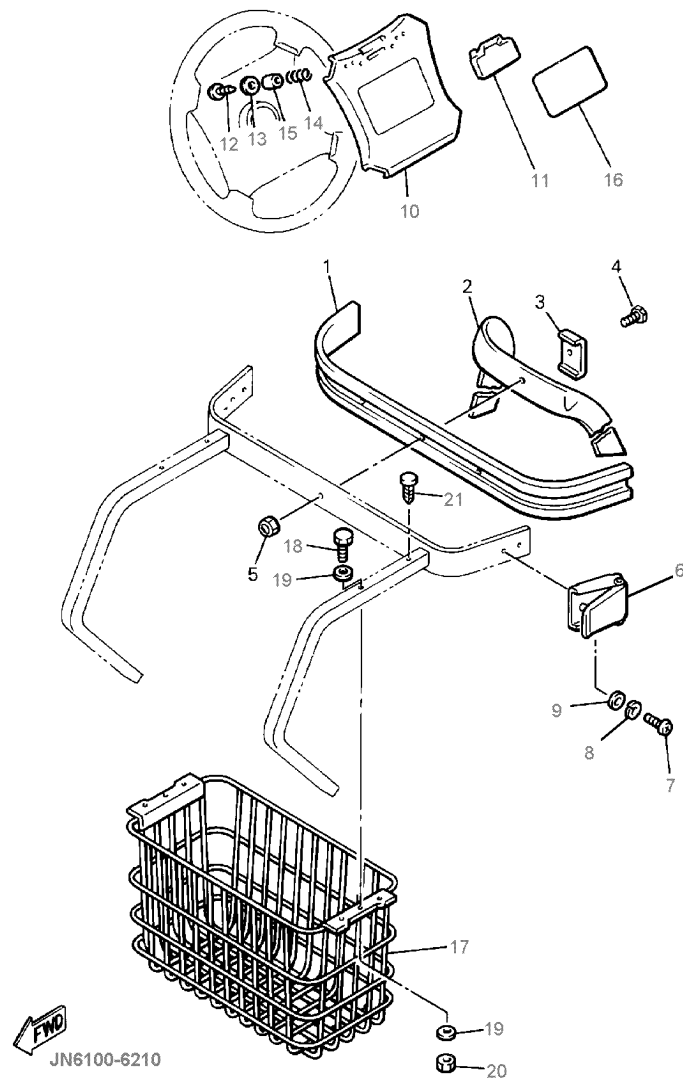

Ref. No.	Part Number	Description	Qty	Remarks
1	JF2-K8356-00-00	PAD, BAG SUPPORT .....	1	
	JN3-K832U-00-00	ENCLOSURE .....	1	
2	JF2-K8355-00-00	BAND .....	1	
3	J38-78367-00-00	PLATE, ANCHOR .....	1	
4	90101-06865-00	BOLT, HEX. ....	1	
5	90185-06836-00	NUT, SELF LOCKING .....	1	
6	JN6-K8380-00-00	LOCK ASSEMBLY. ....	2	
7	98580-06010-00	SCREW, PAN HEAD (92503-06010) .....	4	
8	92995-06100-00	WASHER, SPRING .....	4	
9	92990-06200-00	WASHER .....	4	
10	JN3-K8357-00-00	HOLDER, .....	1	
11	JN6-K8358-00-00	HOLDER, .....	1	
12	97707-40625-00	SCREW, TAPPING .....	2	
13	90201-044H9-00	WASHER, PLAIN .....	2	
14	90502-10013-00	SPRING, CONICAL .....	2	
15	90387-046N7-00	COLLAR .....	2	
16	JN3-K7762-01-00	LABEL, WARNING .....	1	
17	JN3-K8340-00-00	LUGGAGE RACK .....	1	
18	90111-08803-00	BOLT, HEX. SOCKET .....	2	
19	90201-08103-00	WASHER, PLAIN .....	4	
20	90185-08832-00	NUT, SELF-LOCKING .....	2	
21	90338-09828-00	PLUG .....	2	

# SEAT

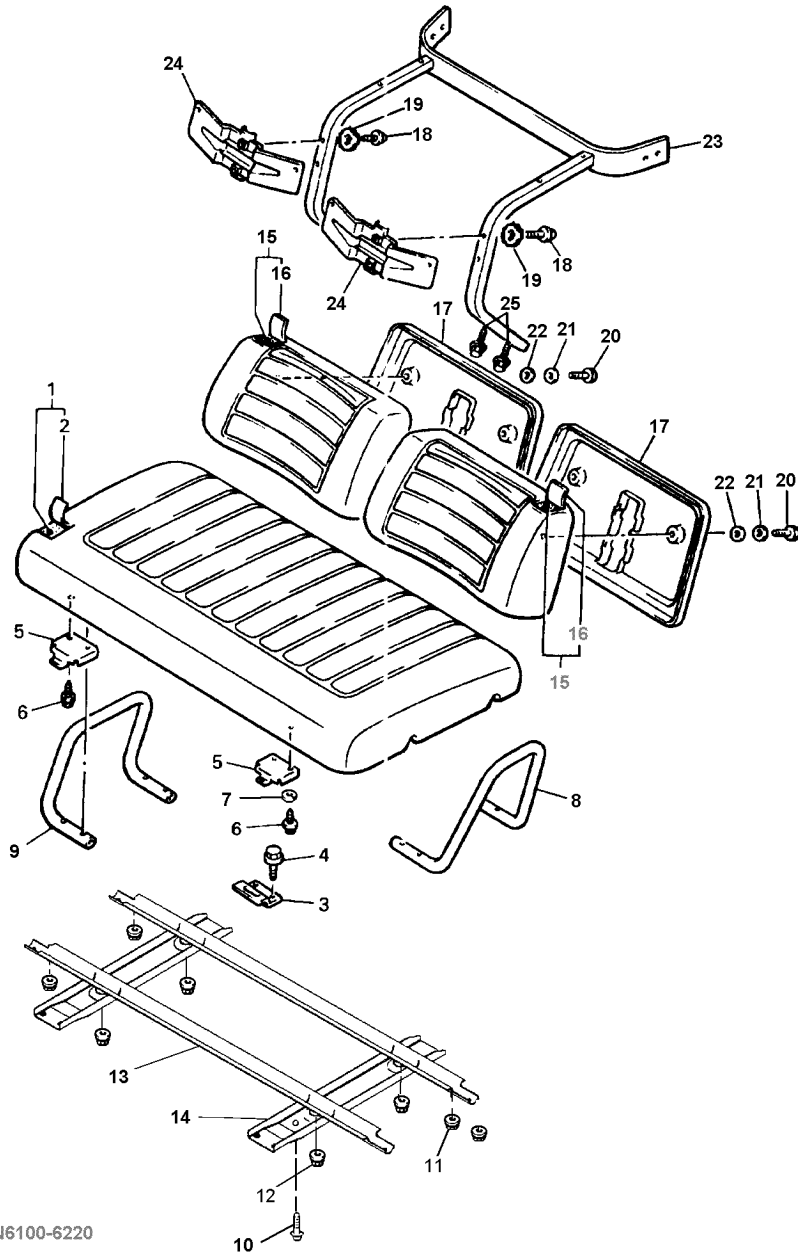

Ref. No.	Part Number	Description	Qty	Remarks
1	JN6-K8401-00-00	CUSHION SEAT .....	1	
2	JN6-K8404-09-00	. COVER, SEAT .....	1	
3	JF2-K8427-00-00	HINGE, SEAT FEMALE .....	2	
4	90105-06903-00	BOLT, WASHER BASED .....	4	
5	JN3-K8426-00-00	HINGE, SEAT MALE .....	2	
6	97395-05012-00	BOLT HEX. HEAD .....	4	
7	92990-05100-00	WASHER, SPRING .....	4	
8	JN3-K8361-00-00	ARM REST .....	1	
9	JN6-K8362-00-00	ARMREST .....	1	
10	90167-04815-00	SCREW, P/H TAPPING .....	4	
11	90185-08839-00	NUT, SELF LOCKING .....	8	
12	95617-08200-00	NUT, SELF-LOCKING (95607-08200-00) .....	4	
13	JN6-K8121-00-00	REINFORCEMENT .....	2	
14	JN6-K8122-00-00	REINFORCEMENT .....	2	
15	JN3-K8402-00-00	BACK, SEAT SUB. ....	2	
16	JN3-K841G-09-00	. COVER, SEAT BACK .....	1	
17	JN3-K8413-00-00	COVER, SEAT BACK .....	2	
18	90119-08820-00	BOLT, HEX. W/WASHER .....	4	
19	90201-098J4-00	WASHER, PLAIN .....	4	
20	95880-06025-00	BOLT, FLANGE .....	4	
21	90201-068G0-00	WASHER, PLAIN .....	4	
22	90201-068G6-00	WASHER, PLAIN .....	4	
23	JN3-K8423-00-00	SUPPORT, SEAT BACK .....	1	
24	JN3-K842H-00-00	RETAINER, SEAT .....	2	
25	95817-08045-00	BOLT, FLANGE .....	4	

# STARTER GENERATOR

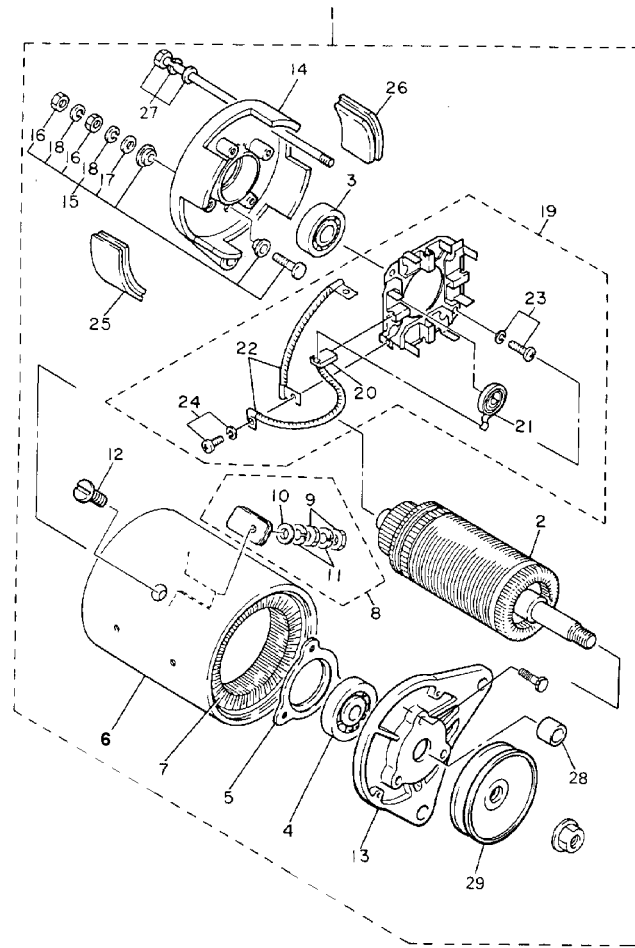

Ref. No.	Part Number	Description	Qty	Remarks
1	JN6-H1100-00-00	STARTER GENERATOR	1	
2	JN3-81150-00-00	. ARMATURE ASSEMBLY	1	
3	J10-81157-10-00	. BEARING 1 (6202 SD)	1	
4	J10-81158-10-00	. BEARING 2 (6203 SD)	1	
5	JN3-81159-00-00	. HOLDER, BEARING	1	
6	J38-81110-10-00	. STATOR ASSEMBLY	1	
7	J38-81160-10-00	. FIELD COIL ASSEMBLY	1	
8	J10-81148-10-00	. SCREW	2	
9	95380-06600-00	. NUT	4	
10	92990-06600-00	. WASHER, PLATE	2	
11	92995-06100-00	. WASHER, SPRING	4	
12	J10-81146-10-00	. SCREW	4	
13	JN3-81165-00-00	. BRACKET, STARTER GENERATOR 1	1	
14	JN3-81166-00-00	. BRACKET, STARTER GENERATOR 2	1	
15	JN3-81147-00-00	. SCREW 3	2	
16	95380-06600-00	. NUT	4	
17	92990-06600-00	. WASHER, PLATE	2	
18	92995-06100-00	. WASHER, SPRING	4	
19	JN3-81119-00-00	. BRUSH HOLDER ASSEMBLY	1	
20	JF2-81111-00-00	. BRUSH	4	
21	JN3-81113-00-00	. SPRING, BRUSH	4	
22	J10-81115-10-00	. WIRE, LEAD	2	
23	98580-05016-00	. SCREW, PAN HEAD	2	
24	98580-04010-00	. SCREW, PAN HEAD	4	
25	J10-81129-10-00	. COVER, BRUSH	3	
26	J10-81129-10-00	. COVER, BRUSH	1	
27	J10-81145-10-00	. SCREW	2	

CONTINUED ON NEXT FRAME ►



JN6100-6230

# STARTER GENERATOR

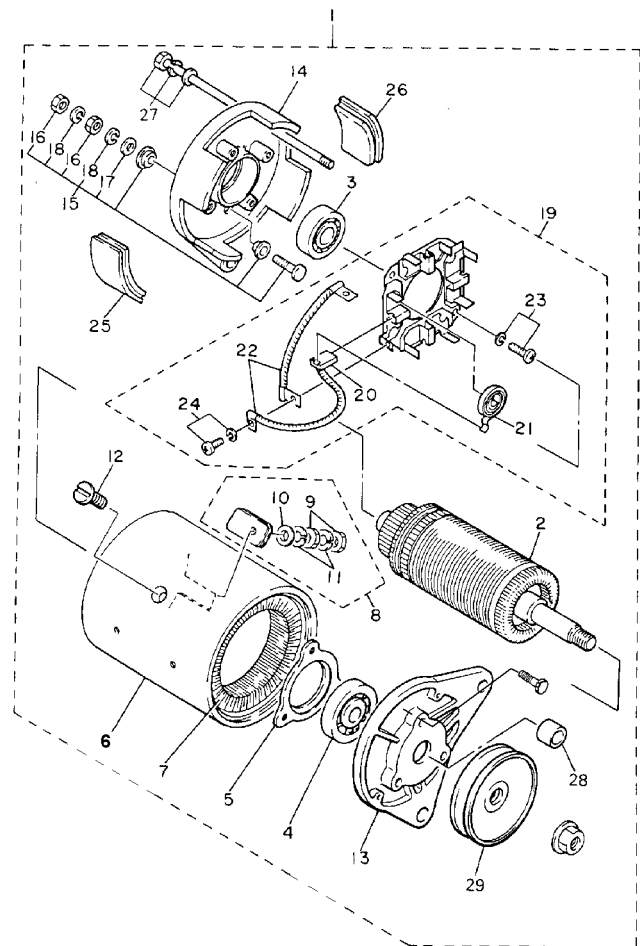

Ref. No.	Part Number	Description	Qty	Remarks
28	JN3-81661-00-00	. SPACER .....	1	
29	JN3-81161-00-00	. PULLEY .....	1	



JN6100-6230

# ELECTRICAL 1

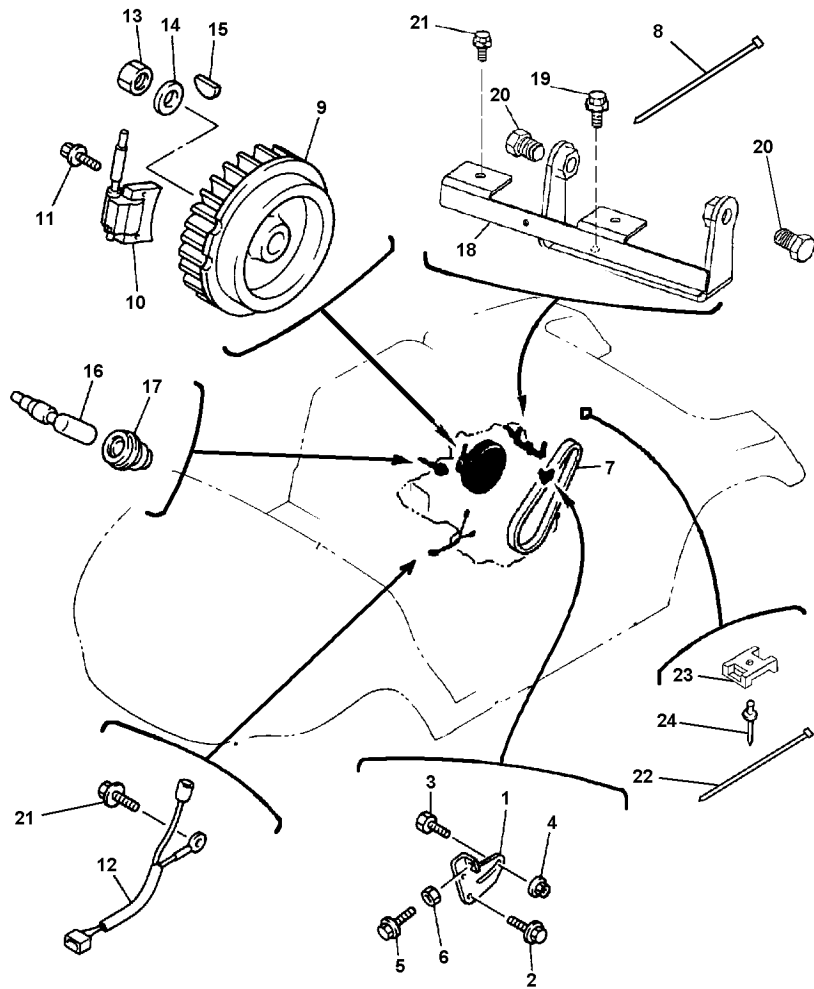

JN6100-6240

Ref. No.	Part Number	Description	Qty	Remarks
1	JN2-81170-00-00	TENSIONER ASSEMBLY .....	1	
2	95827-08020-00	BOLT, FLANGE .....	2	
3	90109-087A5-00	BOLT .....	1	
4	95707-08500-00	NUT, FLANGE .....	1	
5	90101-06478-00	BOLT, HEX. ....	1	
6	95317-06600-00	NUT (95307-06600-00) .....	1	
7	JN6-H1173-00-00	BELT .....	1	
8	90464-09823-00	CLAMP .....	1	
9	JN6-85650-00-00	ROTOR ASSEMBLY. ....	1	
10	JN6-85640-00-00	T.C.I. UNIT .....	1	
11	95817-06025-00	BOLT, FLANGE .....	2	
12	JN6-82318-00-00	WIRE, SUB-LEAD .....	1	
13	95307-18600-00	NUT, HEX. ....	1	
14	90201-18620-00	WASHER, PLAIN .....	1	
15	90280-04052-00	KEY, WOODRUFF .....	1	
16	8K1-82370-20-00	PLUG CAP ASSEMBLY (WITH RESISTOR) .....	1	
17	JE8-82372-00-00	SEAL, PLUG CAP .....	1	
18	JN6-H1171-00-00	BRACKET, STARTER GENERATOR .....	1	
19	95827-08020-00	BOLT, FLANGE .....	2	
20	95827-12025-00	BOLT, FLANGE .....	2	
21	95807-06016-00	BOLT, FLANGE .....	3	
22	90464-40825-00	CLAMP .....	2	
23	90207-05800-00	WASHER, FINISH .....	1	
24	90267-48838-00	RIVET .....	1	

# ELECTRICAL 2

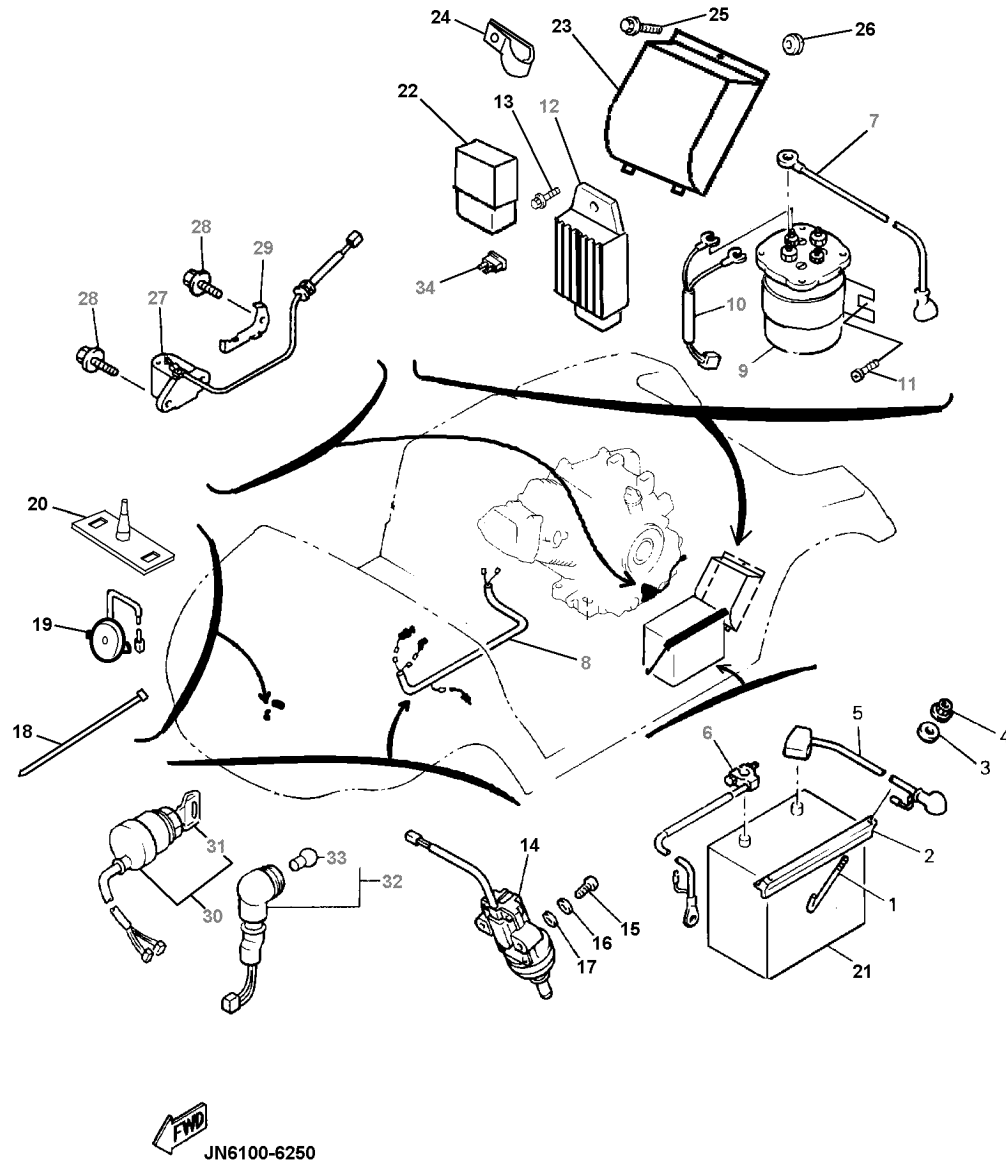

Ref. No.	Part Number	Description	Qty	Remarks
1	JN3-H2133-00-00	SCREW, FITTING	2	
2	J55-H2136-00-00	PLATE, BATTERY	1	
3	92907-06200-00	WASHER	2	
4	95707-06500-00	NUT, FLANGE	2	
5	JN6-H2115-00-00	WIRE, PLUS LEAD	1	
6	JN6-H2116-00-00	WIRE, MINUS LEAD	1	
7	JN6-H2117-00-00	WIRE, LEAD	1	
8	JN6-H2590-00-00	WIRE HARNESS	1	WITH REF. #34 (FUSE)
9	JF2-H1950-00-00	RELAY ASSEMBLY.	1	
10	JN6-H2105-00-00	HARNESS, WIRE	1	
11	90163-06005-00	SCREW, HEX. T	2	
12	JF2-81910-01-00	VOLTAGE REGULATOR	1	
14	JF7-82817-20-00	SWITCH, ACCELERATOR STOP	1	
15	98507-05025-00	SCREW, PAN HEAD	2	
16	92907-05100-00	WASHER, SPRING	2	
17	92907-05600-00	WASHER, PLATE	2	
18	90464-31827-00	CLAMP	4	
19	JR1-H3383-00-00	BUZZER	1	
20	JN6-H3386-00-00	STAY, BUZZER	1	
21	*---	FRONT WHEEL ASSEMBLY	1	
22	4U8-81950-02-00	RELAY ASSEMBLY. (4U8-81950-00)	1	
23	JN6-H1942-00-00	COVER	1	
24	90461-16802-00	CLAMP	1	
25	95817-06016-00	BOLT, FLANGE	2	
26	90480-25856-00	GROMMET	1	
27	JN6-85720-10-00	OIL LEVEL GAUGE	1	
28	95817-06012-00	BOLT, FLANGE	4	
29	JN6-85724-00-00	CLAMP, OIL LEVEL	1	

CONTINUED ON NEXT FRAME ►

# ELECTRICAL 2

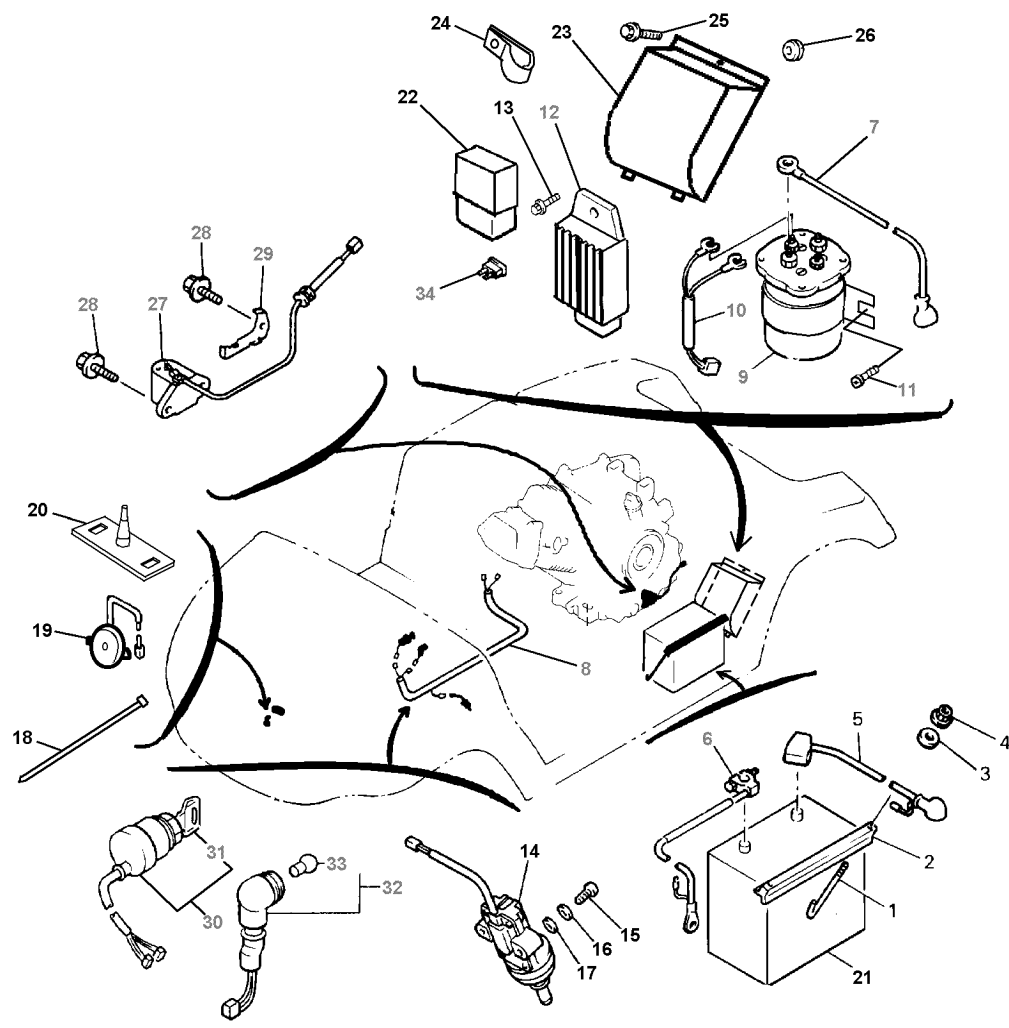

Ref. No.	Part Number	Description	Qty	Remarks
30	JN8-82510-00-00	MAIN SWITCH .....	1	
31	J44-82511-00-YY	. KEY, MAIN SWITCH (J44825110000) .....	1	
32	JN6-83530-00-00	PILOT LAMP A .....	1	
33	123-83516-21-XX	. BULB, (12V-3. 4W) .....	1	
34	42X-82151-00-00	FUSE (10A-BL) .....	1	

 JN6100-6250

## SEAT ADJUSTER (OPTIONAL)

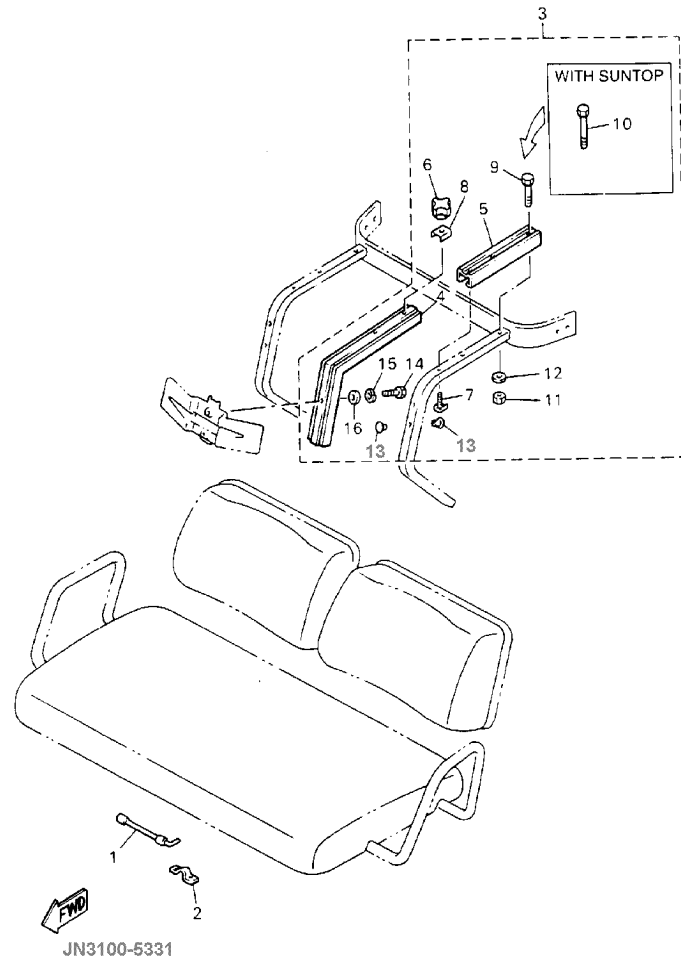

Ref. No.	Part Number	Description	Qty	Remarks
1	JN3-K8421-00-00	SUPPORT, SEAT .....	1	
2	JF2-K8422-00-00	BRACKET, SEAT SUPPORT ..	1	
3	JN3-K8450-00-00	SEAT ADJUSTER ASSEMBLY .	1	
4	JN3-K845A-00-00	. MEMBER, SLIDE SEAT .....	1	
5	JN3-K8451-00-00	. FRAME, SLIDE SEAT .....	1	
6	JN3-K8452-00-00	. SEAT-ADJUSTER .....	1	
7	JN3-K8459-00-00	. REINFORCEMENT, .....	1	
8	JN3-K845E-00-00	. REINFORCEMENT, .....	1	
9	97004-08045-00	. BOLT, HEXAGON .....	2	
10	97004-08070-00	. BOLT, HEXAGON .....	2	
11	95680-08100-00	. NUT, U .....	2	
13	90338-09828-00	. PLUG .....	4	
14	97004-08020-00	. BOLT, HEX. HEAD .....	2	
15	92990-08100-00	. WASHER .....	2	
16	92990-08600-00	. WASHER, PLATE .....	2	

# HUB CAPS (OPTIONAL)

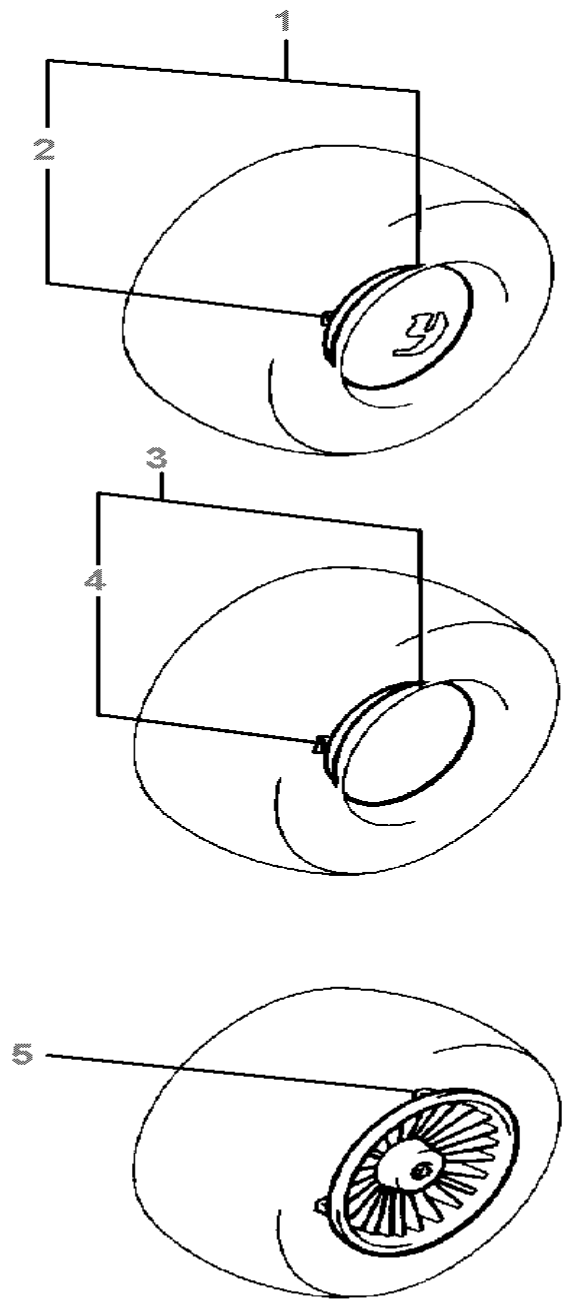

Ref. No.	Part Number	Description	Qty	Remarks
1	JG5-F512K-00-00	HUB-CAP, YAMAHA LOGO ...	4	
2	JG5-F512N-00-00	. CLIP, HUB CAP .....	3	
3	JG5-F512L-00-00	HUB-CAP, PLAIN .....	4	
4	JG5-F512N-00-00	. CLIP, HUB CAP .....	3	
5	JG5-F512M-00-00	HUB-CAP, MAG-STYLE .....	4	COMES WITH CLIPS

 JN6100-6260

## DRAW BAR (OPTIONAL)

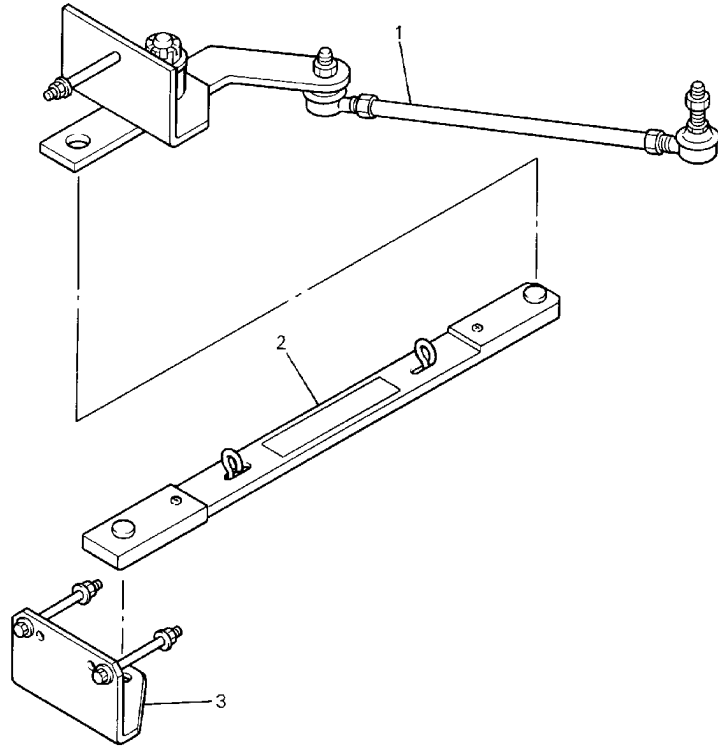

Ref. No.	Part Number	Description	Qty	Remarks
1	JG5-F389K-00-00	ARM, PIVOT ASSEMBLY. ....	1	
2	JG5-F389J-00-00	DRAW BAR ASSEMBLY. ....	1	
3	JG5-F3802-00-00	REAR HITCH ASSEMBLY. ....	1	



JN6100-6270

# WINDSHIELD (OPTIONAL)

Ref. No.	Part Number	Description	Qty	Remarks
1	JN3-K7200-00-00	WINDSHIELD ASSEMBLY. (CLEAR)	1	UR AP
	JN3-K7200-10-00	WINDSHIELD ASSEMBLY. (TINTED)	1	UR AP
2	JN3-K7210-00-00	. WINDSHIELD COMP (CLEAR)	1	UR
3	JN3-K7238-00-00	. . DAMPER, WINDSHIELD	1	
4	JN3-K838C-00-00	. HOLDER SHIELD	2	
5	JN3-K722A-00-00	. FASTENER	2	
6	JN3-K7200-20-00	WINDSHIELD ASSEMBLY. (HINGED, CLEAR)	1	UR AP (CLEAR)
	JN3-K7200-30-00	WINDSHIELD ASSEMBLY. (HINGED, TINTED)	1	UR AP (TINTED)
7	UNA-VAILA-BL-EI 00			
8	JN3-K7238-00-00	. DAMPER, WINDSHIELD	6	
9	90480-10854-00	. GROMMET	2	
10	JN3-K7223-00-00	. FASTENER	2	
11	JN3-K838A-00-00	. RETAINER	2	
12	JN3-K722A-00-00	. FASTENER	1	
13	JN3-K7222-00-00	. BRACKET, WINDSHIELD	2	
14	JN3-K7721-00-00	. BRACKET,	2	

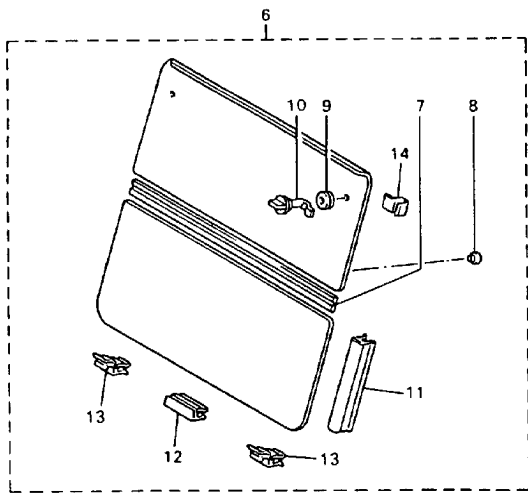
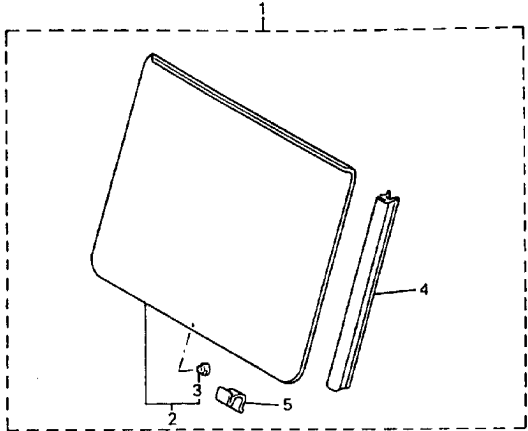

JN3100-6370

## SUN ROOF (OPTIONAL)

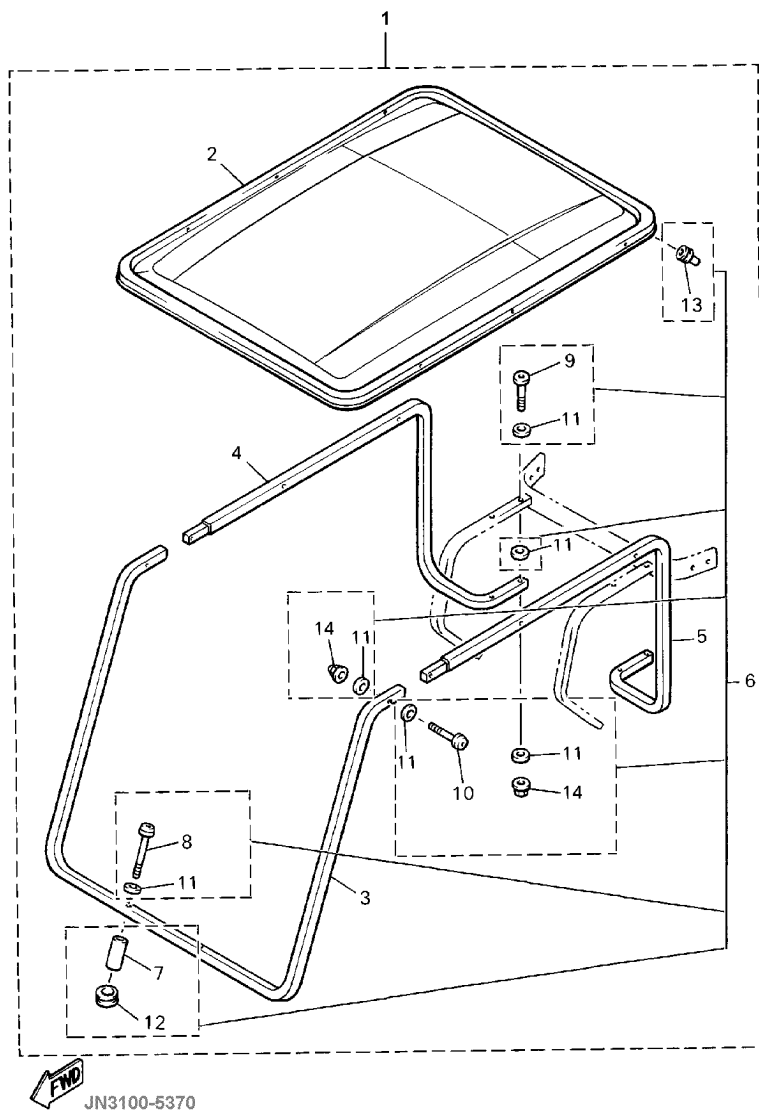

Ref. No.	Part Number	Description	Qty	Remarks
1	JN3-K8310-10-00	SUN ROOF ASSEMBLY .....	1	
2	JN3-K8314-00-00	. COVER, SUNROOF .....	1	
3	JN3-K8312-00-00	. SUPPORT, ROOF .....	1	
4	JN3-K831A-00-00	. SUPPORT, ROOF .....	1	
5	JN3-K8313-00-00	. SUPPORT, ROOF .....	1	
6	ABA-JN398-99-00	. SUN ROOF ASSEMBLY HARDWARE .....	1	
7	90387-088J4-00	.. COLLAR .....	2	
8	92017-08085-00	.. BOLT, HEX .....	2	
9	92017-08070-00	.. BOLT, HEX .....	4	
10	92017-08045-00	.. BOLT, HEX .....	6	
11	90201-087F0-00	.. WASHER, PLATE .....	24	
12	JN3-K832F-00-00	.. GROMMET, ROOF .....	2	
13	JN3-K832G-00-00	.. GROMMET, ROOF .....	2	
14	90185-08089-00	.. NUT, SELF-LOCKING .....	10	

## SPIKE GUARD (OPTIONAL)

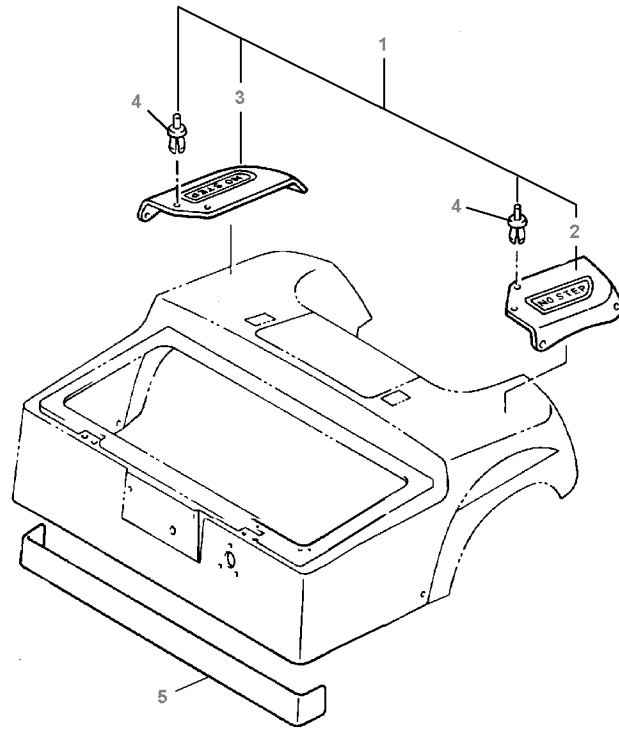

Ref. No.	Part Number	Description	Qty	Remarks
1	SPI-KEGRD-KI-T0	SPIKE GUARD SET .....	1	
2	JN3-K8243-00-00	. MAT, BODY SIDE LEFT .....	1	
3	JN3-K8244-00-00	. MAT, BODY SIDE RIGHT .....	1	
4	90269-07810-00	. RIVET .....	10	
5	JN3-K814N-00-00	PLATE, ORNAMENT .....	1	



JN6100-6290

# FLEET NUMBERS (OPTIONAL)

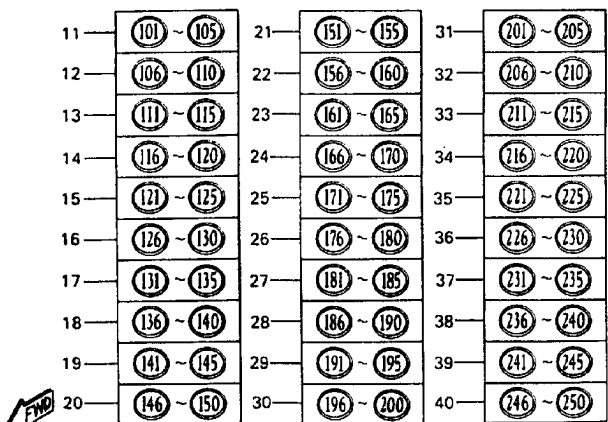
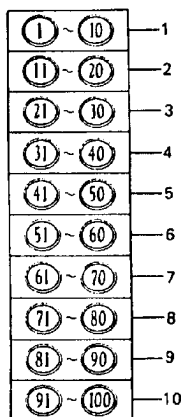
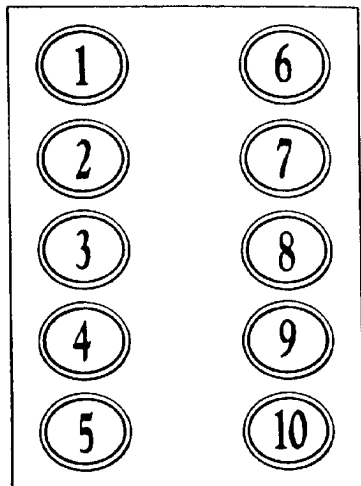

JN3100-6400

Ref. No.	Part Number	Description	Qty	Remarks
1	JG5-K810T-10-00	FLEET, NUMBER .....	1	
2	JG5-K810T-20-00	FLEET, NUMBER .....	1	
3	JG5-K810T-30-00	FLEET, NUMBER .....	1	
4	JG5-K810T-40-00	FLEET, NUMBER .....	1	
5	JG5-K810T-50-00	FLEET, NUMBER .....	1	
6	JG5-K810T-60-00	FLEET, NUMBER .....	1	
7	JG5-K810T-70-00	FLEET, NUMBER .....	1	
8	JG5-K810T-80-00	FLEET, NUMBER .....	1	
9	JG5-K810T-90-00	FLEET, NUMBER .....	1	
10	JG5-K810T-00-00	FLEET, NUMBER .....	1	
11	JG5-K810U-A0-00	FLEET, NUMBER .....	1	
12	JG5-K810U-10-00	FLEET, NUMBER .....	1	
13	JG5-K810U-E0-00	FLEET, NUMBER .....	1	
14	JG5-K810U-20-00	FLEET, NUMBER .....	1	
15	JG5-K810U-F0-00	FLEET, NUMBER .....	1	
16	JG5-K810U-30-00	FLEET, NUMBER .....	1	
17	JG5-K810U-G0-00	FLEET, NUMBER .....	1	
18	JG5-K810U-40-00	FLEET, NUMBER .....	1	
19	JG5-K810U-H0-00	FLEET, NUMBER .....	1	
20	JG5-K810U-50-00	FLEET, NUMBER .....	1	
21	JG5-K810U-J0-00	FLEET, NUMBER .....	1	
22	JG5-K810U-60-00	FLEET, NUMBER .....	1	
23	JG5-K810U-K0-00	FLEET, NUMBER .....	1	
24	JG5-K810U-70-00	FLEET, NUMBER .....	1	
25	JG5-K810U-L0-00	FLEET, NUMBER .....	1	
26	JG5-K810U-80-00	FLEET, NUMBER .....	1	
27	JG5-K810U-M0-00	FLEET, NUMBER .....	1	
28	JG5-K810U-90-00	FLEET, NUMBER .....	1	
29	JG5-K810U-N0-00	FLEET, NUMBER .....	1	

CONTINUED ON NEXT FRAME ➤

# FLEET NUMBERS (OPTIONAL)

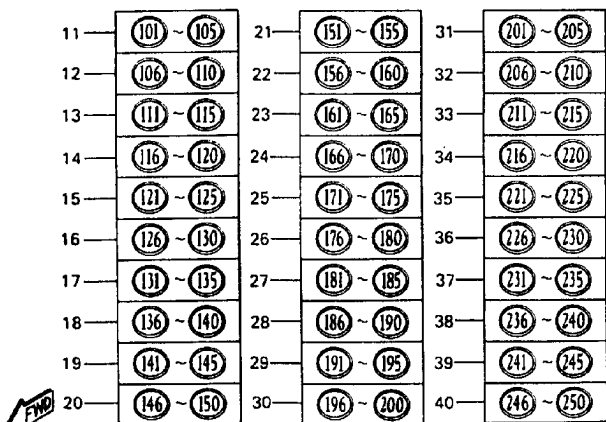
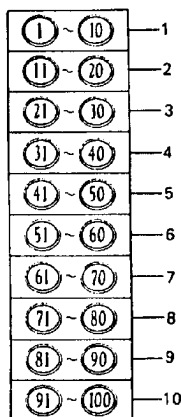
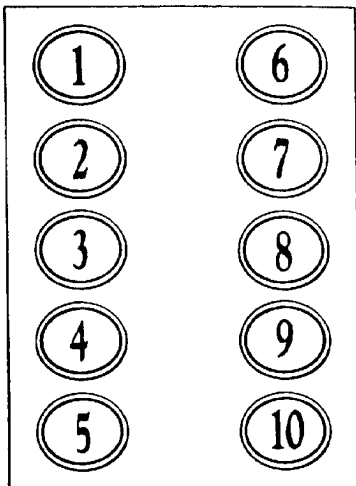

JN3100-6400

Ref. No.	Part Number	Description	Qty	Remarks
30	JG5-K810U-00-00	FLEET, NUMBER .....	1	
31	JG5-K810V-A0-00	FLEET, NUMBER .....	1	
32	JG5-K810V-10-00	FLEET, NUMBER .....	1	
33	JG5-K810V-E0-00	FLEET, NUMBER .....	1	
34	JG5-K810V-20-00	FLEET, NUMBER .....	1	
35	JG5-K810V-F0-00	FLEET, NUMBER .....	1	
36	JG5-K810V-30-00	FLEET, NUMBER .....	1	
37	JG5-K810V-G0-00	FLEET, NUMBER .....	1	
38	JG5-K810V-40-00	FLEET, NUMBER .....	1	
39	JG5-K810V-H0-00	FLEET, NUMBER .....	1	
40	JG5-K810V-50-00	FLEET, NUMBER .....	1	

# SAND BOTTLE - RAKE (OPTIONAL)

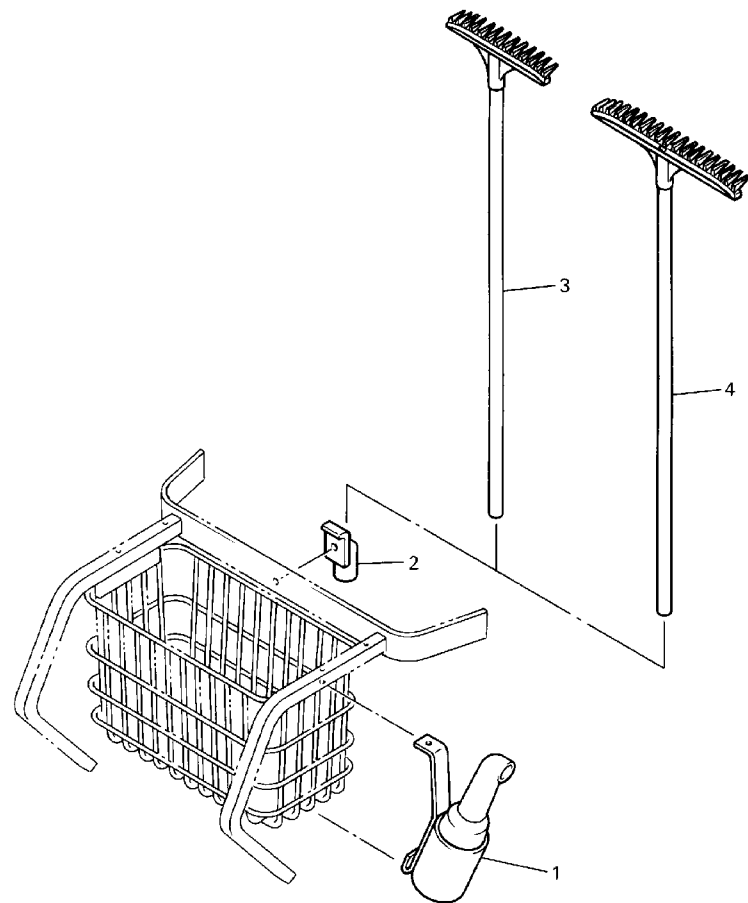

Ref. No.	Part Number	Description	Qty	Remarks
1	JN3-K8309-00-00	SAND BOTTLE ASSEMBLY ...	1	
2	JG5-K834G-00-00	HOLDER, RAKE .....	1	
3	JG5-K834H-00-00	RAKE, SAND .....	1	
4	JG5-K834J-00-00	RAKE, SAND .....	1	

 JN3100-5400

## LIGHT KIT (OPTIONAL)

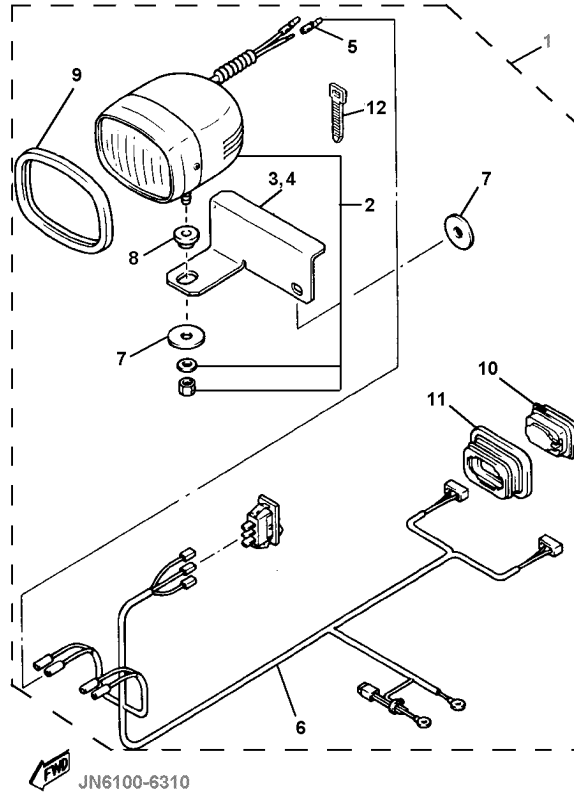

Ref. No.	Part Number	Description	Qty	Remarks
1	JN6-H430A-00-00	LIGHT KIT ASSEMBLY. ....	1	
2	JN3-H4300-00-00	. HEAD LIGHT UNIT .....	2	
3	JN3-H4118-00-00	. STAY, HEAD LIGHT .....	1	
4	JN3-H4119-00-00	. STAY, HEAD LIGHT .....	1	
5	90890-05159-00	. TERMINAL, WIRE (9E2121040100) .....	2	
6	JN6-H4159-00-00	. CORD, HEAD LIGHT .....	1	
7	90201-108G2-00	. WASHER, PLAIN .....	4	
8	JN3-H4366-00-00	. DAMPER, HEAD .....	2	
9	JN3-K7165-00-00	. TRIM, .....	2	
10	JN3-H4700-00-00	. TAIL LIGHT ASSEMBLY .....	2	
11	JN3-H4718-00-00	. GROMMET, TAIL .....	2	
12	90464-14806-00	. CLAMP .....	25	

# ENCLOSURE (OPTIONAL)

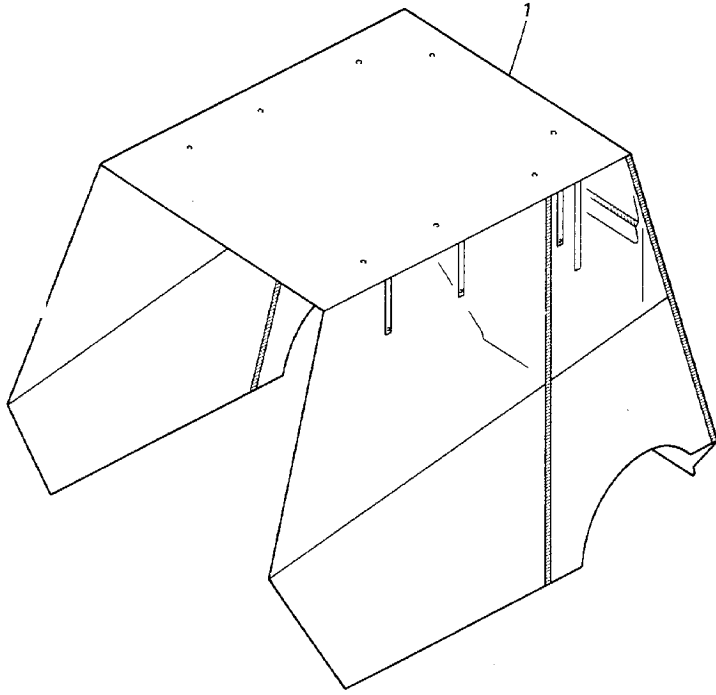

Ref. No.	Part Number	Description	Qty	Remarks
1	JN3-K832U-00-00	ENCLOSURE .....	1	



JN3100-6440

# YAMAHA Service News

May 1996

Volume 2 Issue 10

News YOU can USE..



## G19E MAC charger technical assistance

**T**he G19E is a nifty new car that also has a nifty new type of battery charger. It's a programmed constant voltage / constant current charger that will take the worry out of golf car battery charging.

For questions regarding what the LED lights are trying to tell you, feel free to call us at Golf Car Service at 800-345-5545. If you have any questions about technical aspects of the unit or need to order any parts, feel free to call MAC representatives and speak with them directly.

MAC Chargers  
(Motor Appliance Corporation)

800-622-3406

Tom Lloyd	Service Manager
Robert Welsh	Technician
Glen Robertson	Technician

### INSIDE

- New secondary clutch for G16A
- New primary clutch for G16A
- Fuel tank pick-up parts available
- G16A/E and G19E Service Manuals
- G19E Controller plug
- G16A Engine breather hose clamps
- Warranty parts; Tag 'em or trash 'em
- G16A Fuel system changes

## G14 Floor mat changes

**W**hen ordering floor mats for a G14 or for a 1993 or later G8 (JF2-K8233-10), order two additional new rivets (90269-08813-00) for each mat from YPAD.

The new lower floor mat you receive, JF2-K8233-11, is the same mat, but with two additional places to install rivets.

The new rivets are the reusable type, to ease removal for opening the service lid. Rivet holes are already in the floorpan, so installation is quick and easy.

**NOTE:** If you wish to install the new rivets in the existing center locations, drill out the two floorpan holes from 7.0mm to 8.0mm and order 4 of the new rivets, instead of 2. Don't forget to apply rust proof paint to the new edges of the drilled holes.

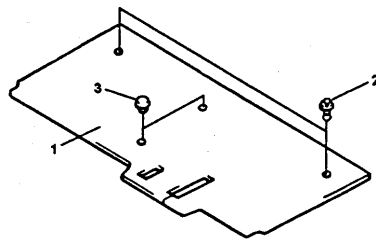

Ref No.	Part No.	Description	Qty	Remarks
1	JF2-K8233-11-00	Mat, main floor	3	Replaces *-10" mat
2	90269-08813-00	Rivet	2	New rivets for 2 corner locations
3	90269-07809-00	Rivet	2	Standard for 2 center locations

Later production G14's are fitted with the new mat and four rivets. The floor panels, mat holes and rivets have been commonized so that one type of rivet is used.

Page 2

## New secondary clutch for G16A

**O**ur new secondary clutch sheaves are made in Canada by guys that are real savvy about belt clutches.

The most obvious change is the aluminum fixed sheave.

The material for both sheaves was changed to a much harder aluminum material. And, with the harder material came a "modular" mold, capable of handling the harder material on a very consistent basis. The result is that the sheaves require no additional finish machining, leaving the hard "as cast" chilled layer that minimizes friction and wear.

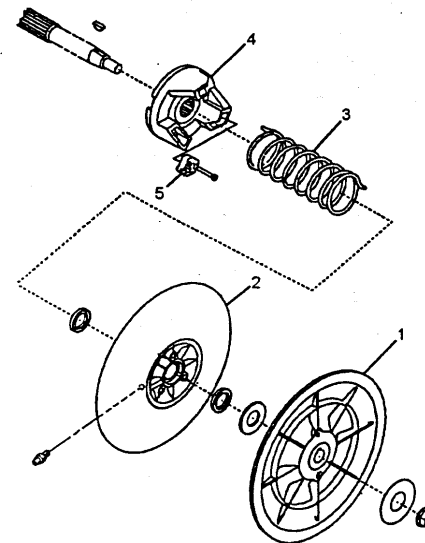

Ref No.	Part No.	Description	Qty
1	JN6-G6260-00-00	Secondary Fixed Sheave	1
2	JN6-G6270-00-00	Secondary Sliding Sheave	1
3	90508-45844-00	Spring, Torsion	1
4	JN6-G6280-00-00	Secondary Spring Seat	1
5	JN6-E7688-00-00	Ramp Shoe	3

See microfiche and the upcoming Country Club Parts Books for complete parts listings for primary and secondary clutches.

News YOU can USE..



## New primary clutch for G16A

**M**ade by Comet to exacting YAMAHA specifications, this new clutch is American made, has less moving parts and increased reliability.

The sliding sheave bushings and seals appear almost identical to the previous models, but are improved. Greasing maintenance (grease the fitting once a year) stays the same. The sliding sheave is a new much harder material, just like the new secondary clutch.

The new Spider assembly slides into the sliding sheave and the assembly threads onto the fixed sheave. A special tool is required for Spider removal. (U.S. dealers will receive a letter and the tools this spring.)

Component service and exchange is simplified. Use engine assembly grease (like Lubriplate™) to ease assembly of spider weights and rollers. Use Teflon™ spray on the slider surfaces.

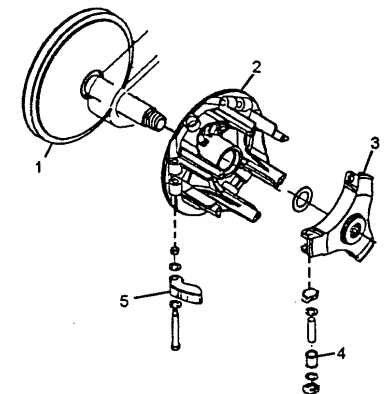

Ref No.	Part No.	Description	Qty
1	JN6-G6210-00-00	Primary Fixed sheave	1
2	JN6-G6220-00-00	Primary Sliding Sheave	1
3	JN6-G6251-00-00	Spider	1
4	JN6-G6258-00-00	Roller Collar	3
5	JN6-G6232-00-00	Weight 1	3

News YOU can USE..



## Fuel tank pickup tube parts now available for G14A/16A

Individual parts are available if needed to replace the fuel pick-up tube, O-ring or hardware. Future parts lists will include this information. For now you get it here, or you can find it in the G16A Parts Catalog, in the Optional Fuel Gauge section, Figure 44.



Ref No.	Part No.	Description	Qty
1	JN3-F4300-00-00	Fuel pipe joint	1
2	93210-228C4-00	O-ring	1
3	98507-05014-00	Screw, pan head	4
4	92907-05100-00	Washer, lock	4
5	92907-05600-00	Washer, plain	4

## G16A/E and G19E Service Manuals

"The longer we have to work on them, the better the manuals will be." This is always true with new products.

We took the cars apart and put them back together. We did things to them and then asked our service personnel to fix them (Boy, that was fun).

Look for these new Service Manual Supplements by the first of May. They will be provided in a separate binder that will go along side your G14A/E manual. Mr. Ed will provide details to you by letter very soon.

## G19E controller plug

Trouble shooting the G19 is an easy proposition if you understand that the control unit performs more functions than any previous model. For instance, the control unit now controls the forward/reverse switching and the reverse buzzer functions. The key to isolating problems is eliminating other components and wiring connections during your troubleshooting tests.

You may need to disconnect the large multiple connector at the control unit to verify circuits.

**CAUTION:** The female terminals inside the wire harness side of the connector are easily damaged by probing with common tester pins. You can easily create new electrical problems in the system by damaging one of these connectors.

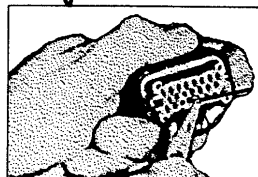
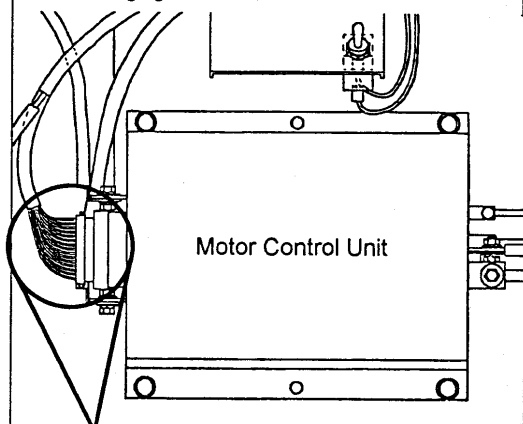

Use care when probing the controller connectors. Do not push tester pins into the slots. Instead, carefully touch the ends with a fine wire

attached to a test clip as shown. A little extra time during these tests is well spent in the long run in preventing future problems.

Before reinstalling the connector, check for presence of light mechanical lubricant in the connectors. If dry, lubricate the plug terminals and pins with STONER E805 Lubricant (800-227-5538) or equivalent.

News YOU can USE..



## Hose clamps added to G16A engine breather hose

We added two hose clamps to the breather hose that connects the valve cover to the front side of the new air cleaner case.

The purpose of the hose is to allow the engine to breathe and direct any crankcase fumes back into the engine, via the air cleaner case.

We noticed that the hose is a snug fit anyway, but we feel the clamps are good insurance. Someone may think that a hose without a clamp must not be that important, which is certainly *not* the case. If the hose is not connected, two bad things happen. The engine breathes into the environment. And, our engine gets a gulp of unfiltered air from the hole opened up in the air cleaner case hose fitting. Both situations are bad news.

Several early production G16A cars (JN3-000101~006700) were designed, produced and delivered without the hose clamps. Cars from JN3-006701 have the clamps installed.

*It is not necessary to run out and add the hose clamps to cars you have already delivered, or add them to current vehicles you may have.* Warranty repair or update is not required. However, during future service we recommend that you update those cars by adding the hose clamps.

Part Number	Description
90464-13847-00	Clamp

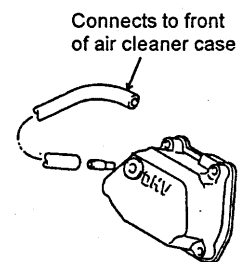
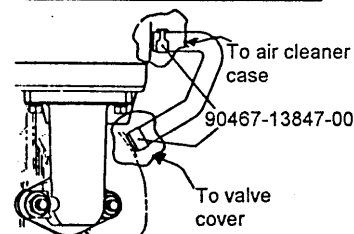

## Warranty parts; Tag 'em or trash 'em

It takes time for you to locate warranty claim parts, box them up and get them to the Post Office. Once they get here, they are extremely valuable to us in showing our engineers how a part failed. They say a picture is worth a thousand words...You can just imagine what an actual failed part can do.

The most critical component of a sample part, however, is the warranty parts tag. It tells us many things vital to our investigation. The serial number alone tells us when the car was produced, sold, which batch the part came in so we know when it was made, etc. The rounds/hours on the car tell us how the part held up compared to our test units...We could go on and on. What's important to you is that without the tag the warranty request may not get paid. It is not necessary to tag individual parts from the same claim. Just secure all the parts for a single claim in one bag and tag the bag!

Warranty parts tags are free so order some today.

LIT-13795-00-92 G/C Warr Parts Tag 25 pack

## G16A Fuel system changes

The air cleaner case is much simpler to service and acts as a carburetor tamper protector.

The carburetor fuel float height is fixed and needs no adjustment, ever.

The pilot screw is set at 1½ turns out. The jet sizes are different from G14A.

The carburetor body uses gaskets on both sides, as well as another one between the phenolic block and the cylinder head. If you remove the air box assembly for any reason, you release the tension on these gaskets, so check them carefully and replace if damaged!

