



PARTS CATALOGUE

MODEL YEAR 1994

G9-EKP (JH72)

Frame Serial No.	JH7-201801~202066	
PUBLICATION	PART NUMBER	REMARKS
OWNER'S MANUAL	LIT-19626-00-56	
ASSEMBLY	LIT-19666-00-56	
SERVICE MANUAL	LIT-19616-G9-93	
COUNTRY CLUB	LIT-1001J-G9-94	

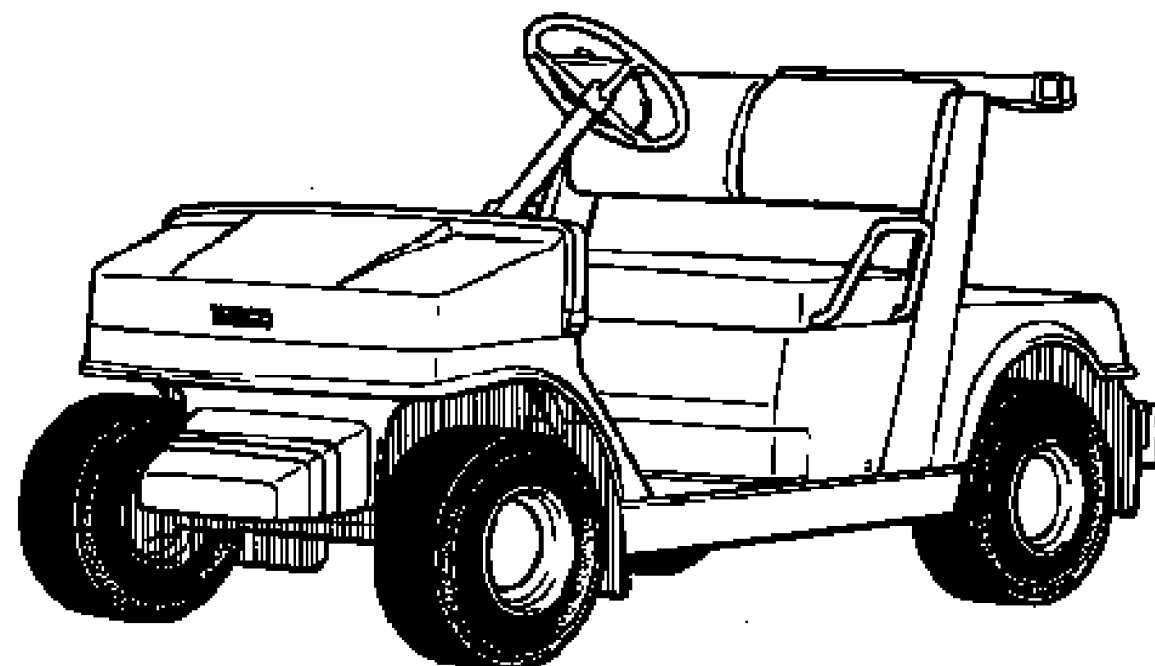

YAMAHA
ONLINE
 Parts & Accessories

A1



REAR ARM - SUSPENSION

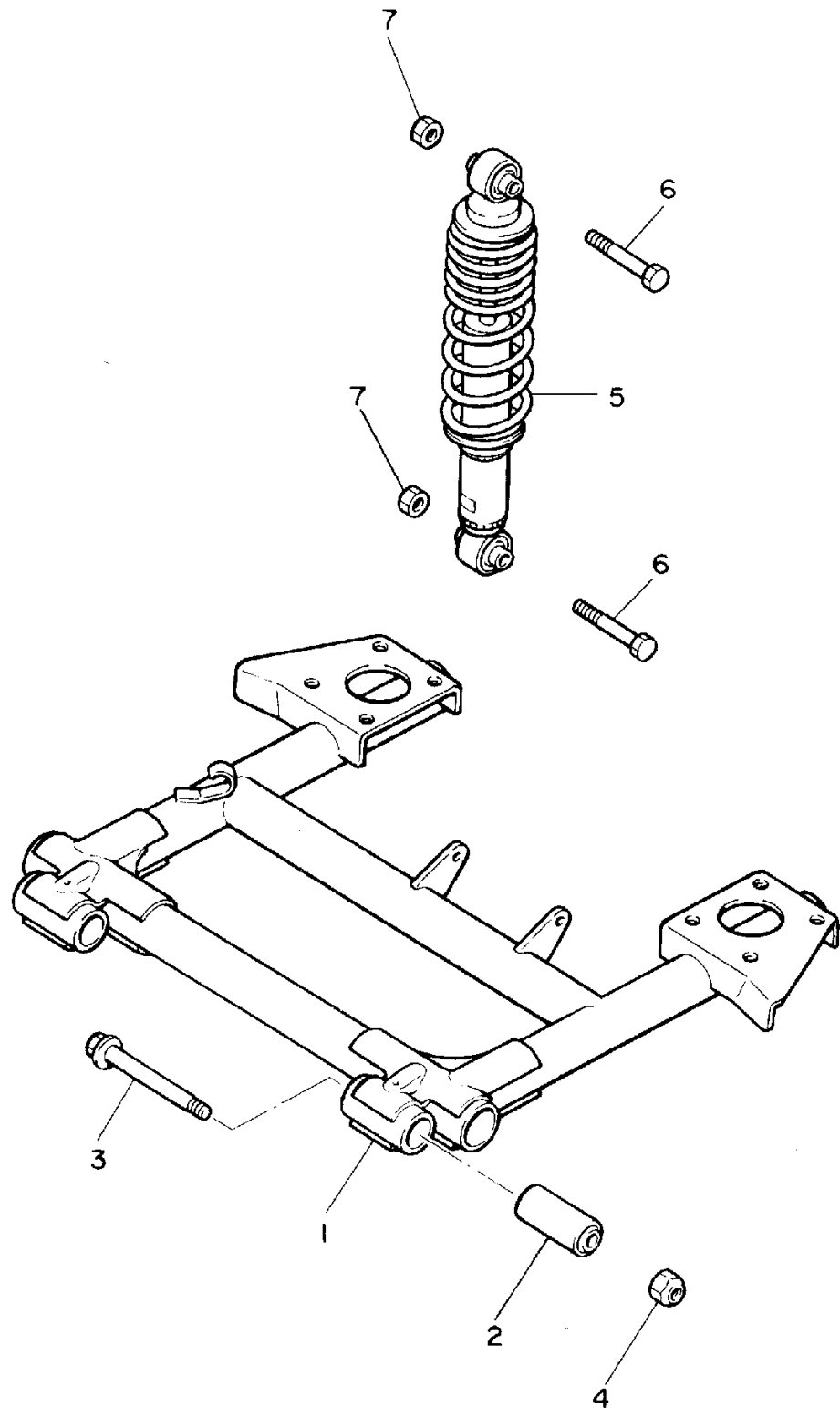

Ref. No.	Part Number	Description	Qty	Remarks
1	J56-F2110-W0-00	REAR ARM COMP. (J56-F2110-00-00)	1	YPAD
2	J10-22123-00-00	BUSH 1	2	
3	90105-10359-00	BOLT, WASHER BASED	2	
4	90185-10115-00	NUT, SELF-LOCKING	2	
5	JG6-F2210-00-00	SHOCK ABSORBER ASSEMBLY, REAR	2	YPAD
6	97022-10055-00	BOLT	4	
7	95601-10100-00	NUT, U (95602-10100-00)	4	

FWD
JH7100-3010

FRAME

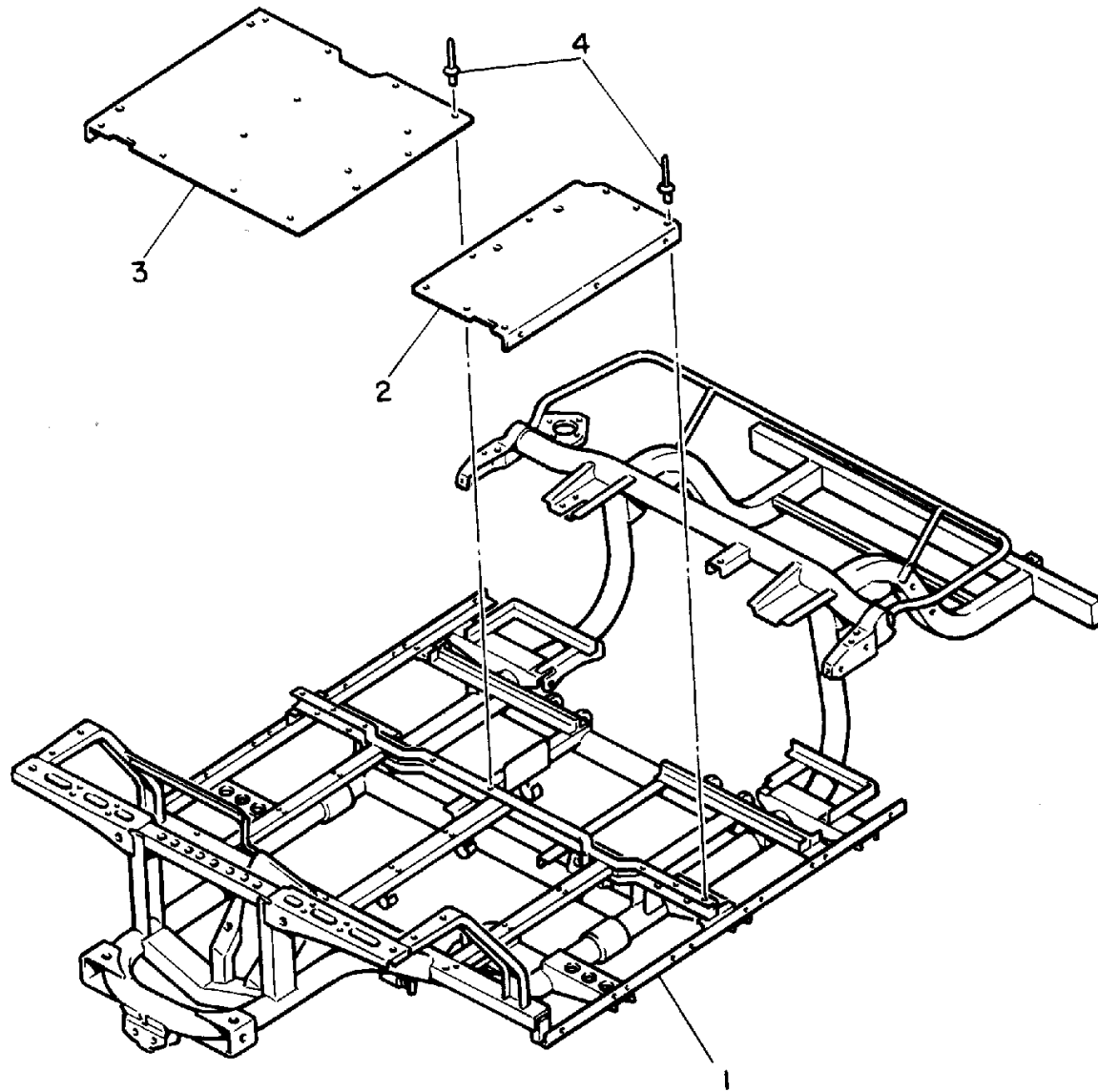

Ref. No.	Part Number	Description	Qty	Remarks
1	JG6-F2501-02-00	FRAME COMP.	1	YPAD
2	J55-F2571-00-00	PANEL 1	1	YPAD
3	J55-F2572-00-00	PANEL 2	1	YPAD
4	90267-40054-00	RIVET, BLIND	20	



JG6100-1020

FRONT SUSPENSION - WHEEL

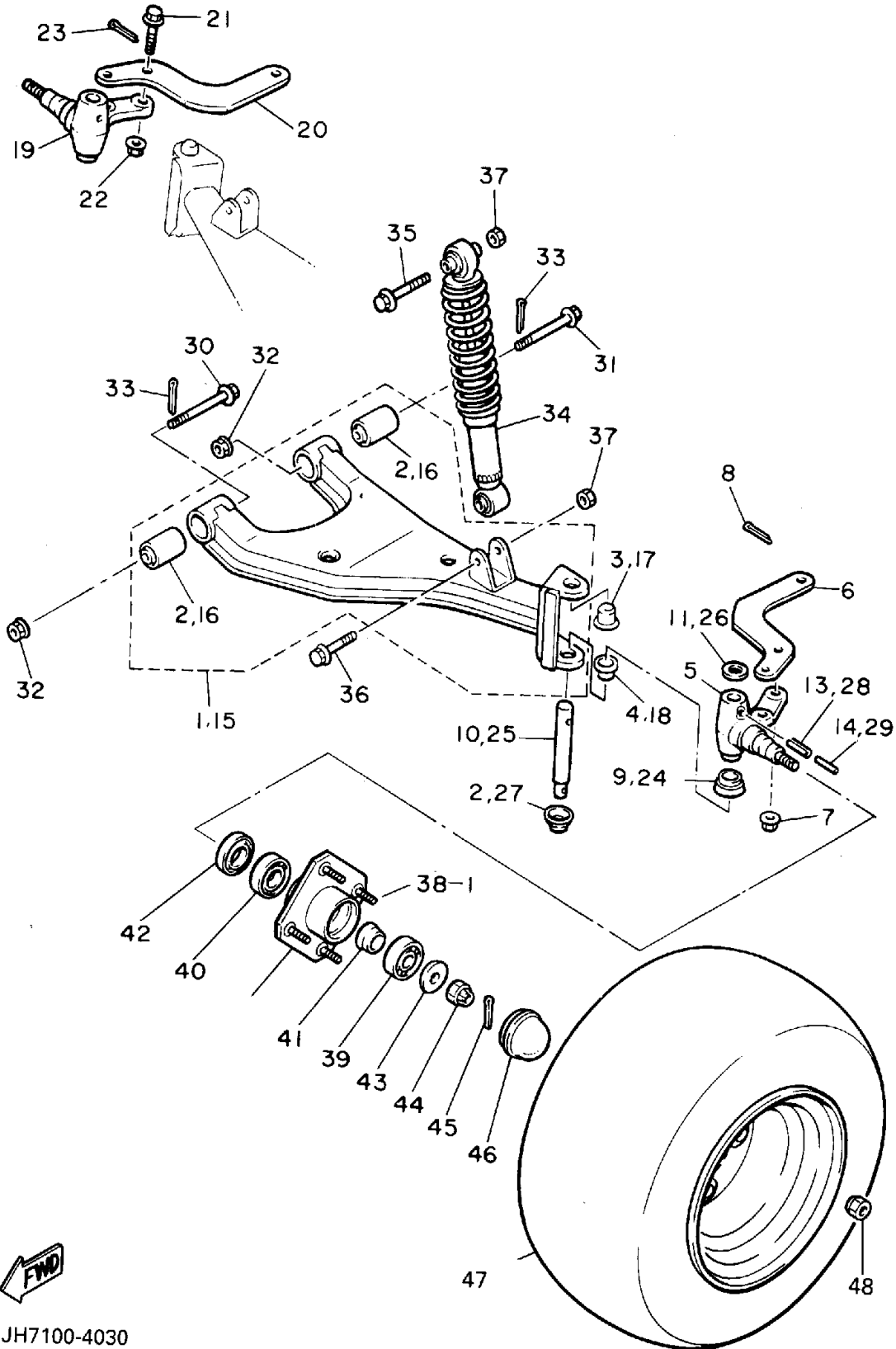

Ref. No.	Part Number	Description	Qty	Remarks
1	J55-F3570-00-00	FRONT LOWER ARM SUB-ASSEMBLY (L.H)	1	YPAD
2	J38-23526-00-00	. BUSH	2	
3	90338-17225-00	PLUG	1	
4	90386-15139-00	BUSH	1	
5	J38-23511-01-00	KNUCKLE, STEERING 1	1	
6	J38-23512-02-00	ARM, KNUCKLE 1	1	
7	90185-10115-00	NUT, SELF-LOCKING	2	
8	91401-25020-00	PIN, COTTER	2	
9	J38-23527-00-00	SEAL, DUST	1	
10	J38-23516-00-00	PIN, STEERING KNUCKLE	1	
11	90201-156J2-00	WASHER, PLAIN	1	
12	J38-23528-00-00	SEAL, DUST	1	
13	91609-60028-00	PIN, SPRING	1	
14	91609-35028-00	PIN, SPRING	1	
15	J55-F3580-00-00	FRONT LOWER ARM SUB-ASSEMBLY (R.H)	1	YPAD
16	J38-23526-00-00	. BUSH	2	
17	90338-17225-00	PLUG	1	
18	90386-15139-00	BUSH	1	
19	J38-23521-01-00	KNUCKLE, STEERING 2	1	
20	J38-23512-02-00	ARM, KNUCKLE 1	1	
21	90105-10360-00	BOLT, FLANGE	4	
22	90185-10115-00	NUT, SELF-LOCKING	2	
23	91401-25020-00	PIN, COTTER	2	
24	J38-23527-00-00	SEAL, DUST	1	
25	J38-23516-00-00	PIN, STEERING KNUCKLE	1	
26	90201-156J2-00	WASHER, PLAIN	1	
27	J38-23528-00-00	SEAL, DUST	1	

CONTINUED ON NEXT FRAME ►



JH7100-4030

FRONT SUSPENSION - WHEEL

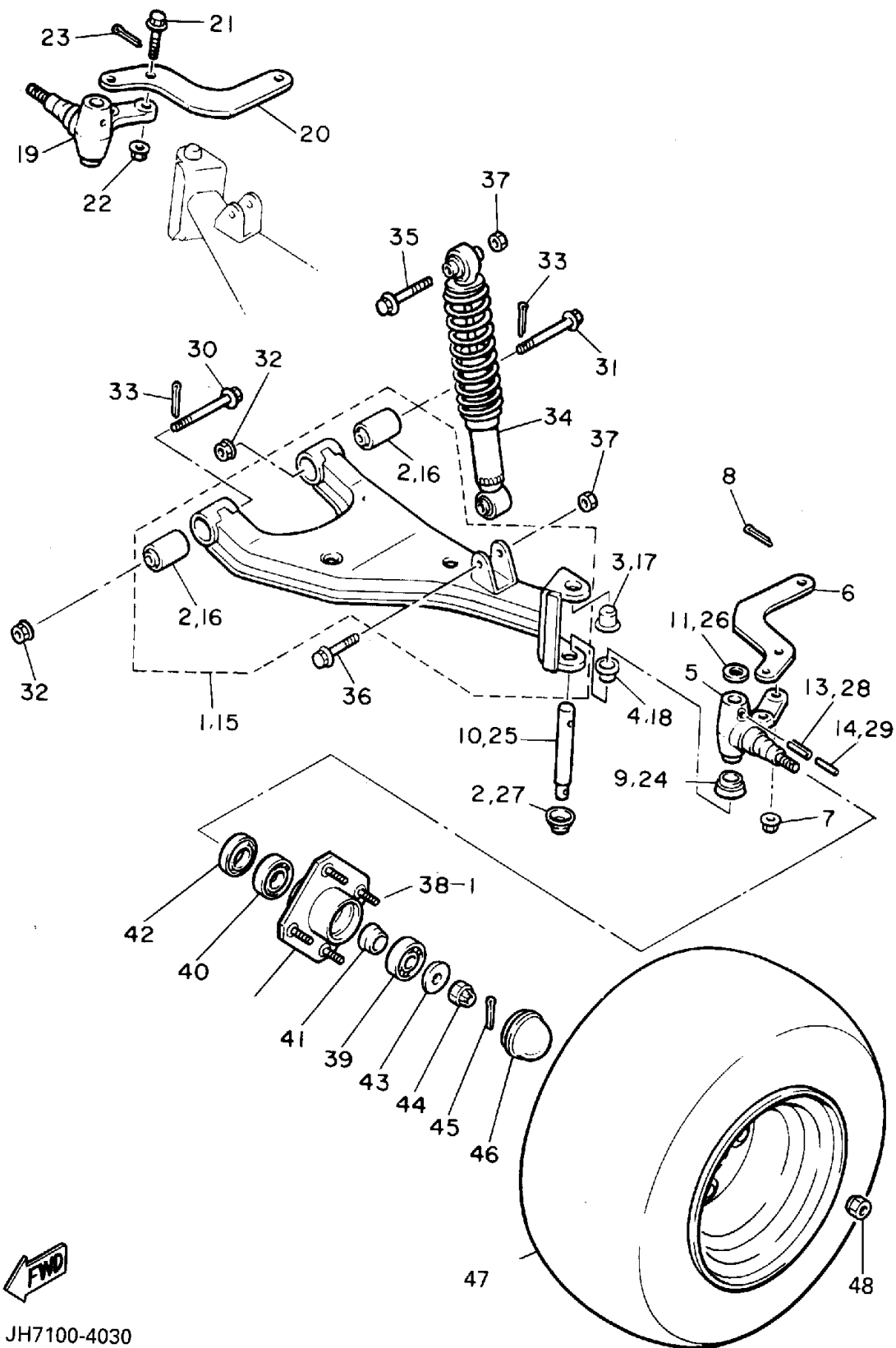

Ref. No.	Part Number	Description	Qty	Remarks
28	91609-60028-00	PIN, SPRING	1	
29	91609-35028-00	PIN, SPRING	1	
30	90105-10357-00	BOLT, FLANGE	2	
31	90105-10357-00	BOLT, FLANGE	2	
32	90185-10115-00	NUT, SELF-LOCKING	4	
33	91401-25020-00	PIN, COTTER	4	
34	JH7-F3350-00-00	SHOCK ABSORBER ASSEMBLY	2	YPAD
35	97002-10065-00	BOLT	2	
36	97012-10050-00	BOLT (97002-10050-00)	2	
37	95601-10100-00	NUT, U (95602-10100-00)	4	
38	JG5-WF511-00-00	HUB	2	YPAD
39	93306-20437-00	BEARING	2	
40	93306-00511-00	BEARING	2	
41	90387-241M7-00	COLLAR	2	
42	93102-30083-00	SEAL, OIL	2	
43	90209-32271-00	WASHER	2	
44	95601-14100-00	NUT, U (95602-14100-00)	2	
45	91401-25020-00	PIN, COTTER	2	
46	J17-25118-00-00	COVER, HUB DUST	2	
47	JG5-F5100-10-00	REAR WHEEL ASSEMBLY ...	2	YPAD
48	90179-12262-00	NUT	8	
38-1	90114-12800-00	. BOLT, RIBBED NECK	4	



JH7100-4030

STEERING

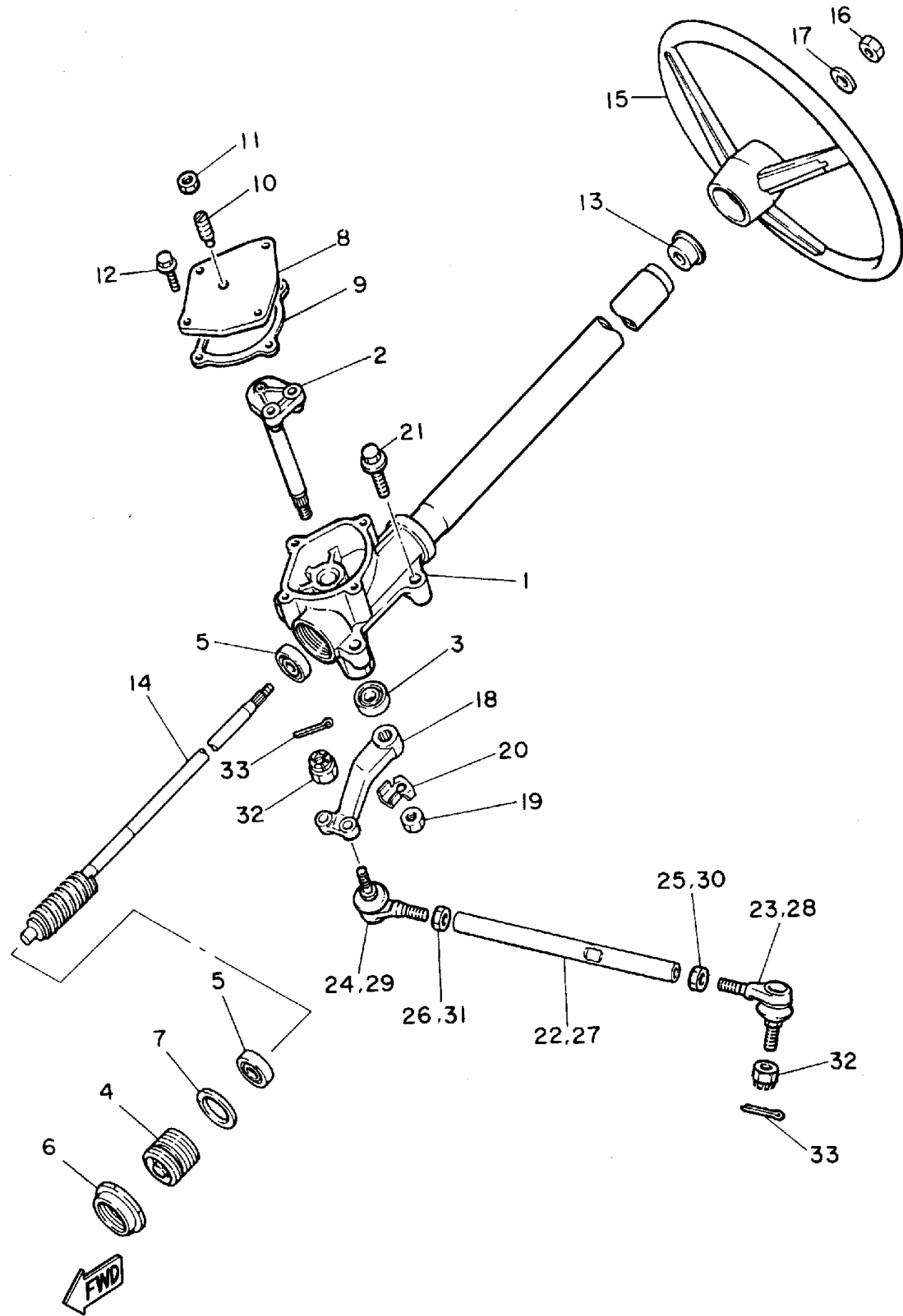

J41110-5040

Ref. No.	Part Number	Description	Qty	Remarks
1	JG5-F3811-00-00	COLUMN, STEERING	1	YPAD
2	J38-23816-00-00	ARM, PITMAN	1	
3	93102-22314-00	SEAL, OIL	1	
4	J55-F3876-00-00	BOLT	1	YPAD
5	93332-00010-00	BEARING	2	
6	J10-23877-00-00	NUT	1	
7	J10-23444-00-00	WASHER	1	
8	J55-23818-00-00	COVER, STEERING	1	
9	J38-23462-00-00	SEAL, STEERING (J38-23462-01-00)	1	
10	J10-23459-00-00	BOLT	1	
11	90170-08024-00	NUT, HEX.	1	
12	95811-06020-00	BOLT, FLANGE	4	
13	J38-23814-00-00	HOLDER, HANDLE UPPER	1	
14	J10-23840-00-00	STEERING SHAFT	1	
15	JF2-F3838-00-00	WHEEL, STEERING	1	YPAD
16	90185-12119-00	NUT, SELF-LOCKING	1	
17	92990-12200-00	WASHER, PLAIN	1	
18	J38-23826-01-00	ARM, IDLER	1	
19	95701-16300-00	NUT, FLANGE	1	
20	90215-16252-00	WASHER, TONGUE	1	
21	95811-10050-00	BOLT, FLANGE (95812-10050-00)	4	
22	J38-23831-02-00	ROD, TIE	1	
23	J38-23841-01-00	JOINT, UNIVERSAL 1	1	
24	J38-23845-01-00	JOINT, UNIVERSAL 2	1	
25	90170-12055-00	NUT	1	
26	90170-12054-00	NUT	1	
27	J38-23837-02-00	ROD, TIE 2	1	

CONTINUED ON NEXT FRAME ►

STEERING

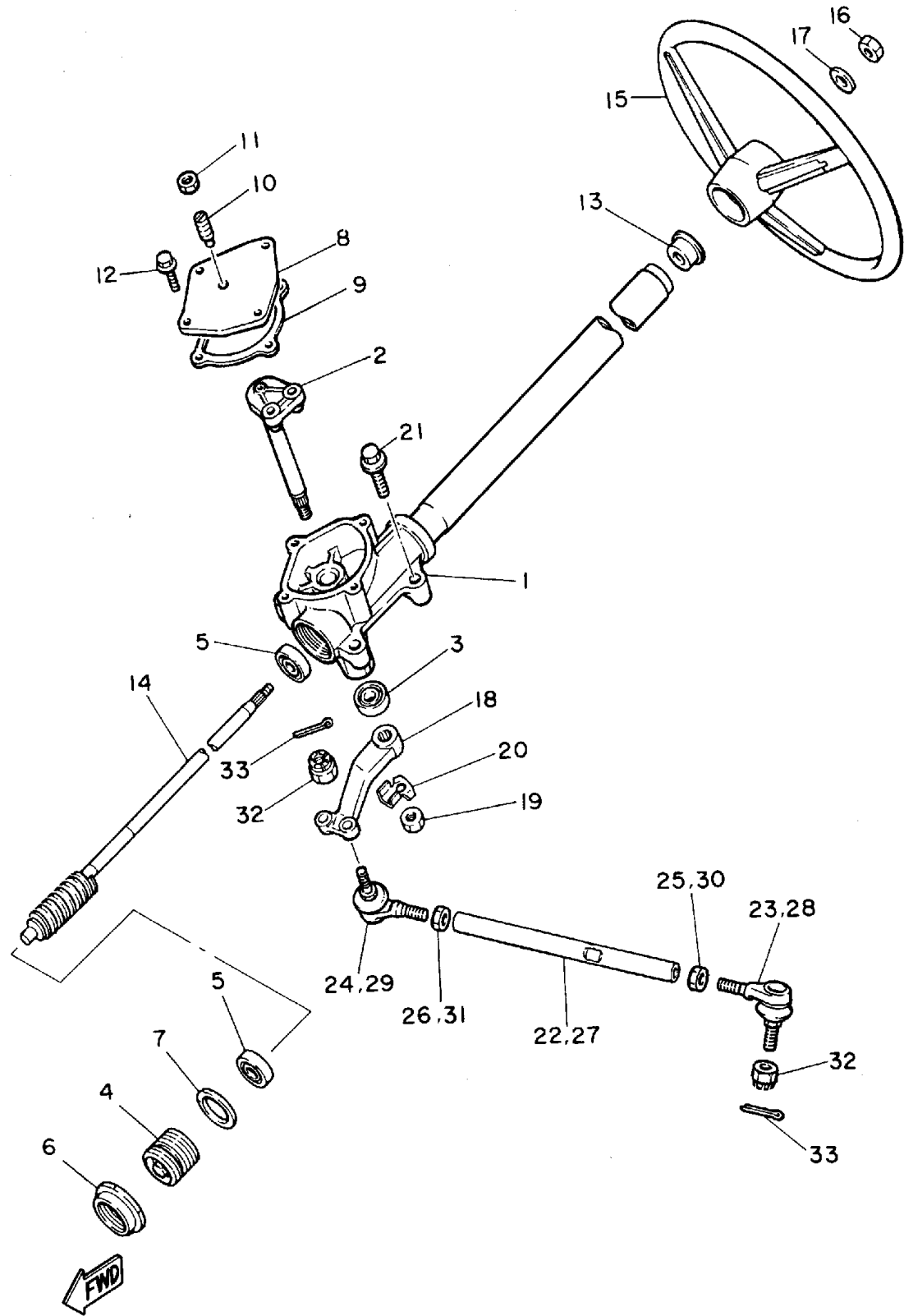

Ref. No.	Part Number	Description	Qty	Remarks
28	J38-23841-01-00	JOINT, UNIVERSAL 1	1	
29	J38-23845-01-00	JOINT, UNIVERSAL 2	1	
30	90170-12055-00	NUT	1	
31	90170-12054-00	NUT	1	
32	95601-10100-00	NUT, U (95602-10100-00)	4	
33	91401-25020-00	PIN, COTTER	4	
	G9E-PARTS-BO-AR	ASSEMBLY, HARDWARE	9	OPTIONAL PART

J41110-5040

BRAKE

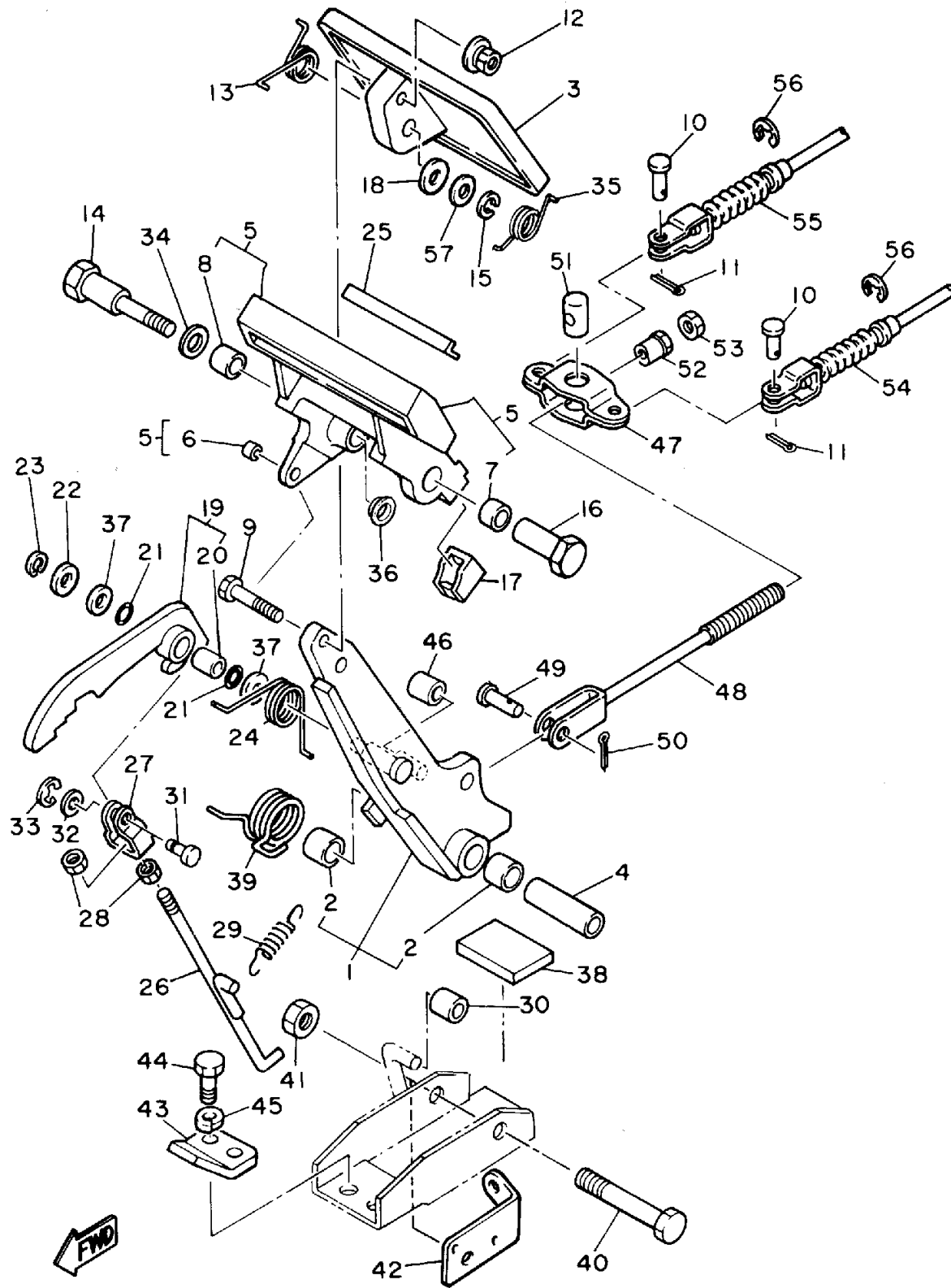

JG5100-1150

Ref. No.	Part Number	Description	Qty	Remarks
1	J17-27250-02-00	BRAKE ARM COMP.	1	
2	90384-14080-00	. BUSH, BIMETAL	2	
3	J10-27211-00-00	PEDAL, BRAKE	1	
4	90387-107F8-00	COLLAR	1	
5	J17-25670-01-00	PARKING PEDAL COMP.	1	
6	90384-05163-00	. BUSH, BIMETAL	1	
7	90384-12164-00	. BUSH, BIMETAL	1	
8	90380-12051-00	. BUSH, SOLID	1	
9	90101-06555-00	BOLT, HEX.	1	
10	91701-08018-00	PIN	4	
11	91490-25020-00	PIN, COTTER	4	
12	90179-07564-00	NUT	1	
13	90508-23542-00	SPRING, TORSION	1	
14	90109-08669-00	BOLT	1	
15	92902-08100-00	WASHER, SPRING	1	
16	90179-08378-00	NUT	1	
17	J17-25679-01-00	DAMPER	2	
18	92990-08200-00	WASHER, PLAIN	1	
19	J17-W2561-00-00	SECTOR, PARKING BRAKE ..	1	
20	90384-10162-00	. BUSH, BIMETAL	1	
21	J17-27221-00-00	SEAL, SHAFT	2	
22	92990-10600-00	WASHER, PLATE	1	
23	99080-07600-00	CIRCLIP (E)	1	
24	90508-14548-00	SPRING, TORSION	1	
25	J17-25672-01-00	PAD, PARKING	1	
26	J17-27231-02-00	ROD, BRAKE	1	
27	J17-27232-00-00	END, ROD	1	
28	95380-06700-00	NUT	2	
29	90506-12277-00	SPRING, TENSION	1	

CONTINUED ON NEXT FRAME ➤

BRAKE

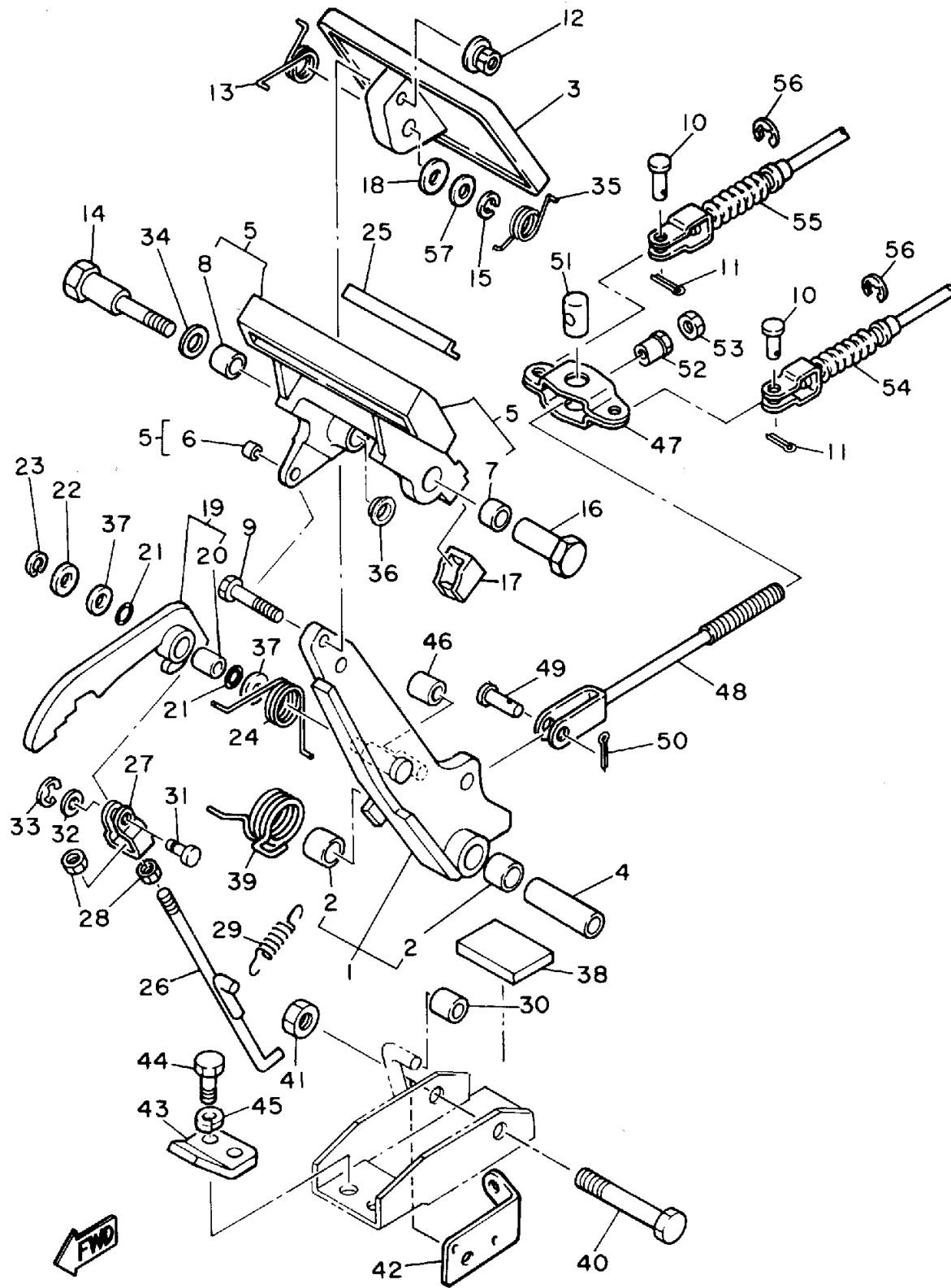

JG5100-1150

Ref. No.	Part Number	Description	Qty	Remarks
30	J17-25673-00-00	DAMPER, BRAKE	1	
31	J17-27228-00-00	PIN, LINK JOINT	1	
32	92901-05600-00	WASHER, PLATE	1	
33	99080-04600-00	CIRCLIP (E)	1	
34	90201-123F2-00	WASHER, PLAIN	1	
35	90508-26557-00	SPRING, TORSION	1	
36	90380-12105-00	BUSH, SOLID	1	
37	90201-104G8-00	WASHER, PLAIN	2	
38	J17-27245-00-00	PAD, BRAKE PEDAL	1	
39	90508-40543-00	SPRING, TORSION	1	
40	90101-10447-00	BOLT, HEX.	1	
41	95601-10100-00	NUT, U (95602-10100-00)	1	
42	J55-2252M-00-00	BRACKET,	1	
43	J17-27246-00-00	NAIL, BRAKE	1	
44	97313-08020-00	BOLT, HEXAGON	2	
45	92902-08100-00	WASHER, SPRING	2	
46	J17-25673-00-00	DAMPER, BRAKE	1	
47	J10-25681-00-00	EQUALIZER, BRAKE	1	
48	J20-25685-00-00	ROD	1	
49	91701-10022-00	PIN	1	
50	91490-30020-00	PIN, COTTER	1	
51	90249-14129-00	PIN	1	
52	90179-08261-00	NUT	1	
53	95303-08700-00	NUT	1	
54	J56-F6341-00-00	CABLE, BRAKE	1	YPAD
55	J56-F6351-00-00	CABLE, BRAKE	1	YPAD
56	99001-09600-00	CIRCLIP	4	
57	J55-27226-00-00	WASHER, LINK	1	

BRAKE 2

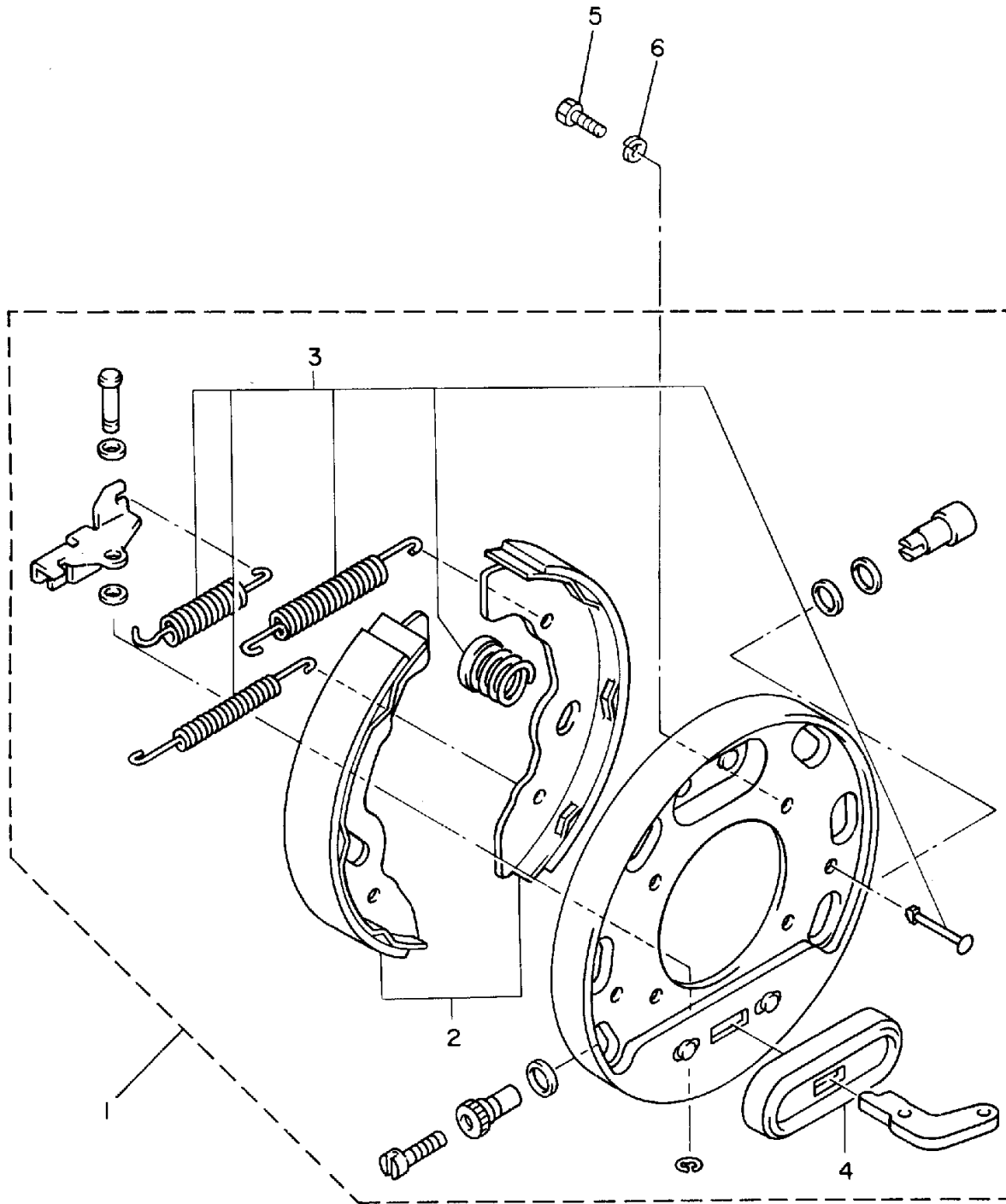

Ref. No.	Part Number	Description	Qty	Remarks
1	JG5-F7280-00-00	BACKING PLATE ASSEMBLY 1 (R.H)	2	YPAD
2	JG5-F5330-00-00	. BRAKE SHOE SET	1	
3	JG5-F819G-00-00	. REPAIR PARTS KIT	1	
4	JG5-F7286-00-00	. COVER, DUST	1	YPAD
5	97011-08016-00	BOLT	4	
6	92902-08100-00	WASHER, SPRING	4	



JG5100-3160

BRAKE 3

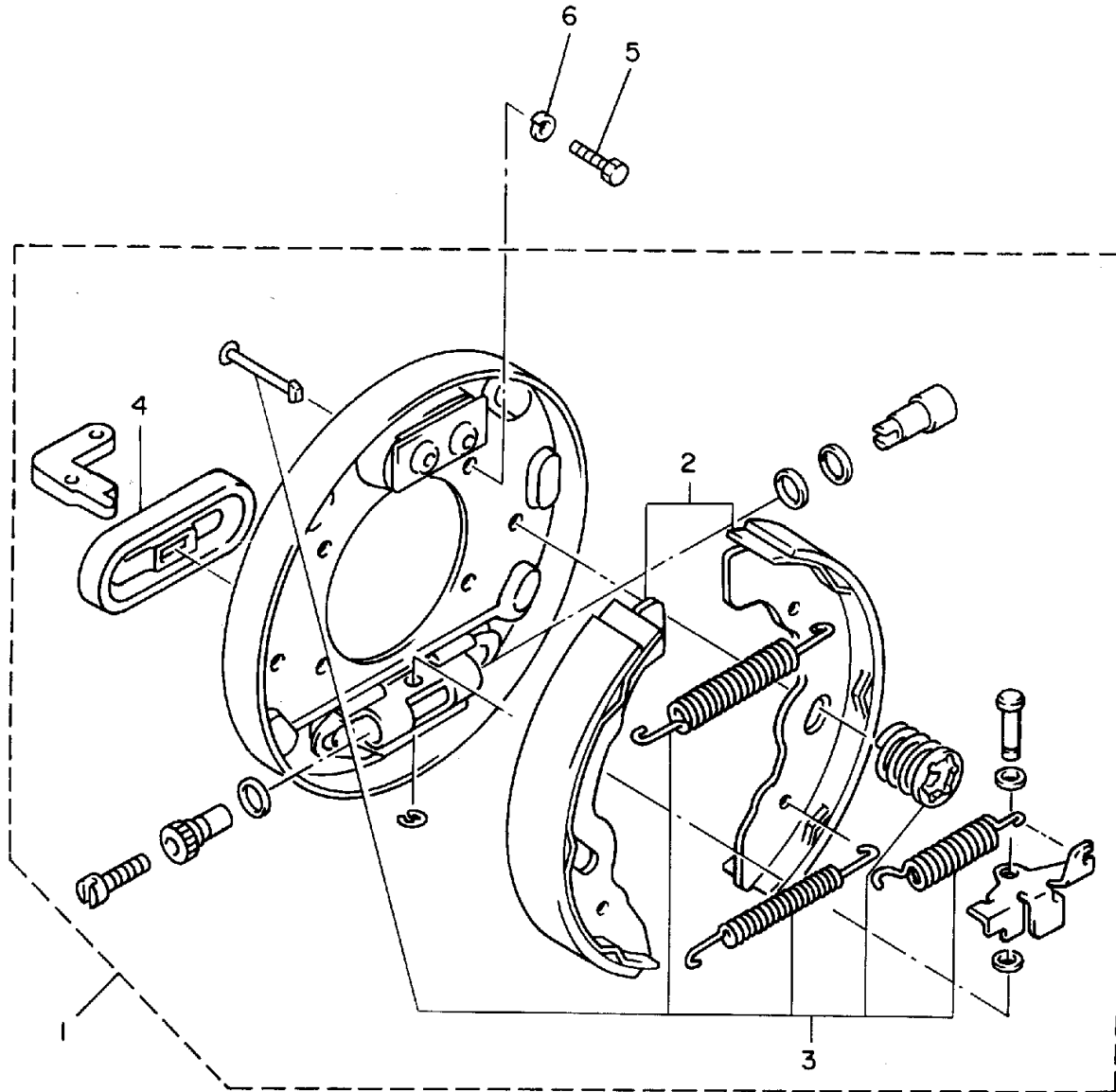

Ref. No.	Part Number	Description	Qty	Remarks
1	JG5-F7290-00-00	BACKING PLATE ASSEMBLY (L.H)	2	YPAD
2	JG5-F5330-00-00	. BRAKE SHOE SET	1	
3	JG5-F819G-00-00	. REPAIR PARTS KIT	1	
4	JG5-F7286-00-00	. COVER, DUST	1	YPAD
5	97011-08016-00	BOLT	4	
6	92902-08100-00	WASHER, SPRING	4	



JG5100-3170

ACCELERATOR

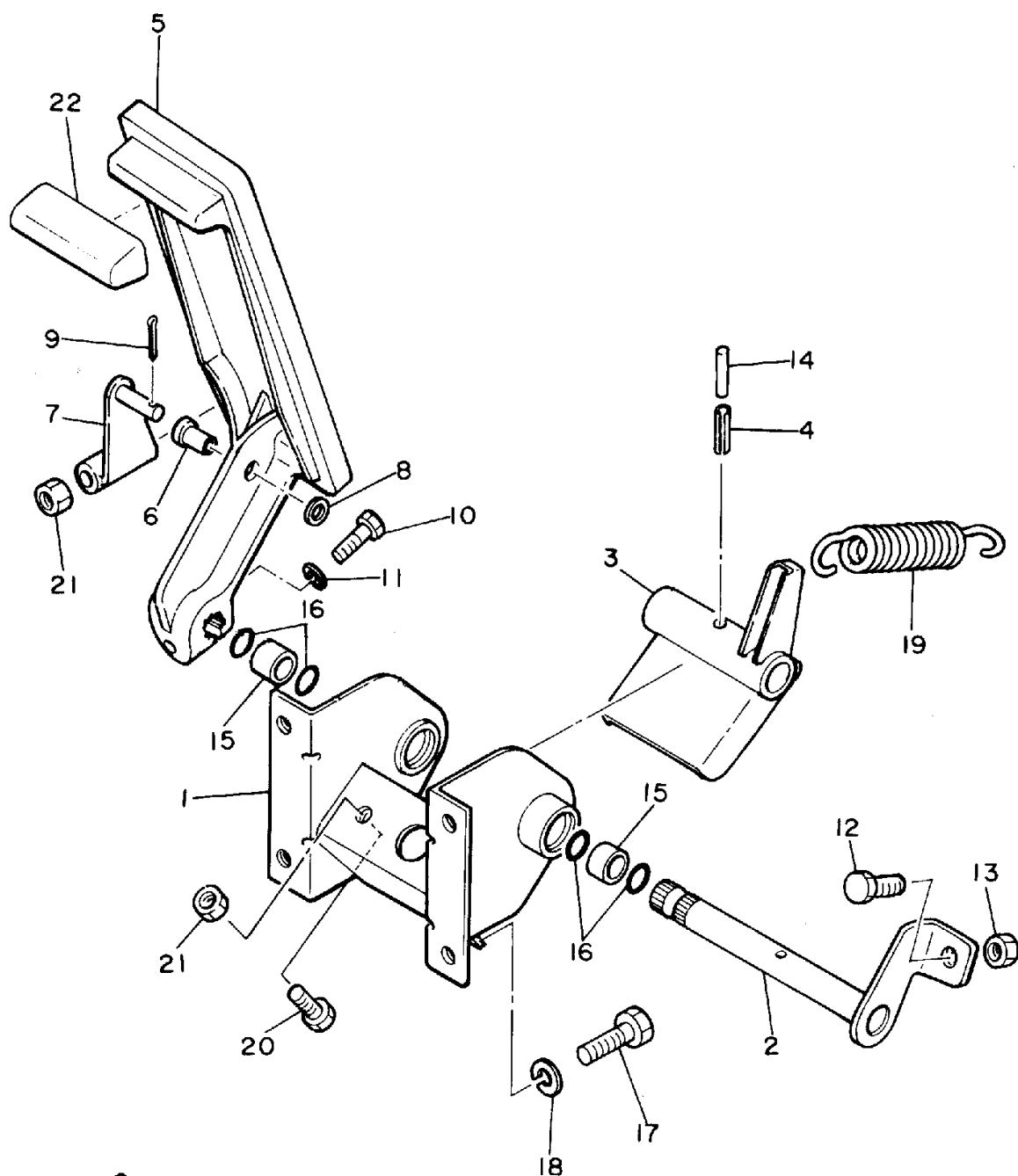

Ref. No.	Part Number	Description	Qty	Remarks
1	J41-27874-00-00	BRACKET, ACCELERATOR		
		PEDAL	1	
2	J17-27853-00-00	SHAFT, PEDAL 1	1	
3	J22-27872-00-00	ARM, ACCELERATOR	1	
4	91609-60028-00	PIN, SPRING	1	
5	JF3-27871-00-00	PEDAL, ACCELERATOR	1	
6	90381-06033-00	BUSH, SOLID	1	
7	J14-27815-00-00	LEVER, CRANK	1	
8	92990-06600-00	WASHER, PLATE	1	
9	91490-20020-00	PIN, COTTER	1	
10	97011-06025-00	BOLT (97001-06025)	1	
11	92995-06100-00	WASHER, SPRING	1	
12	90106-08040-00	BOLT, RD. HEX	1	
13	95303-08700-00	NUT	1	
14	91609-35028-00	PIN, SPRING	1	
15	90384-14080-00	BUSH, BIMETAL	2	
16	93210-14104-00	O-RING	4	
17	97011-06016-00	BOLT	4	
18	92995-06100-00	WASHER, SPRING	4	
19	90506-26282-00	SPRING, TENSION	1	
20	97011-06025-00	BOLT (97001-06025)	1	
21	95380-06700-00	NUT	1	
22	JF2-27854-00-00	COVER, PEDAL	1	



JH7100-3080

TRANSAXLE ASSEMBLY

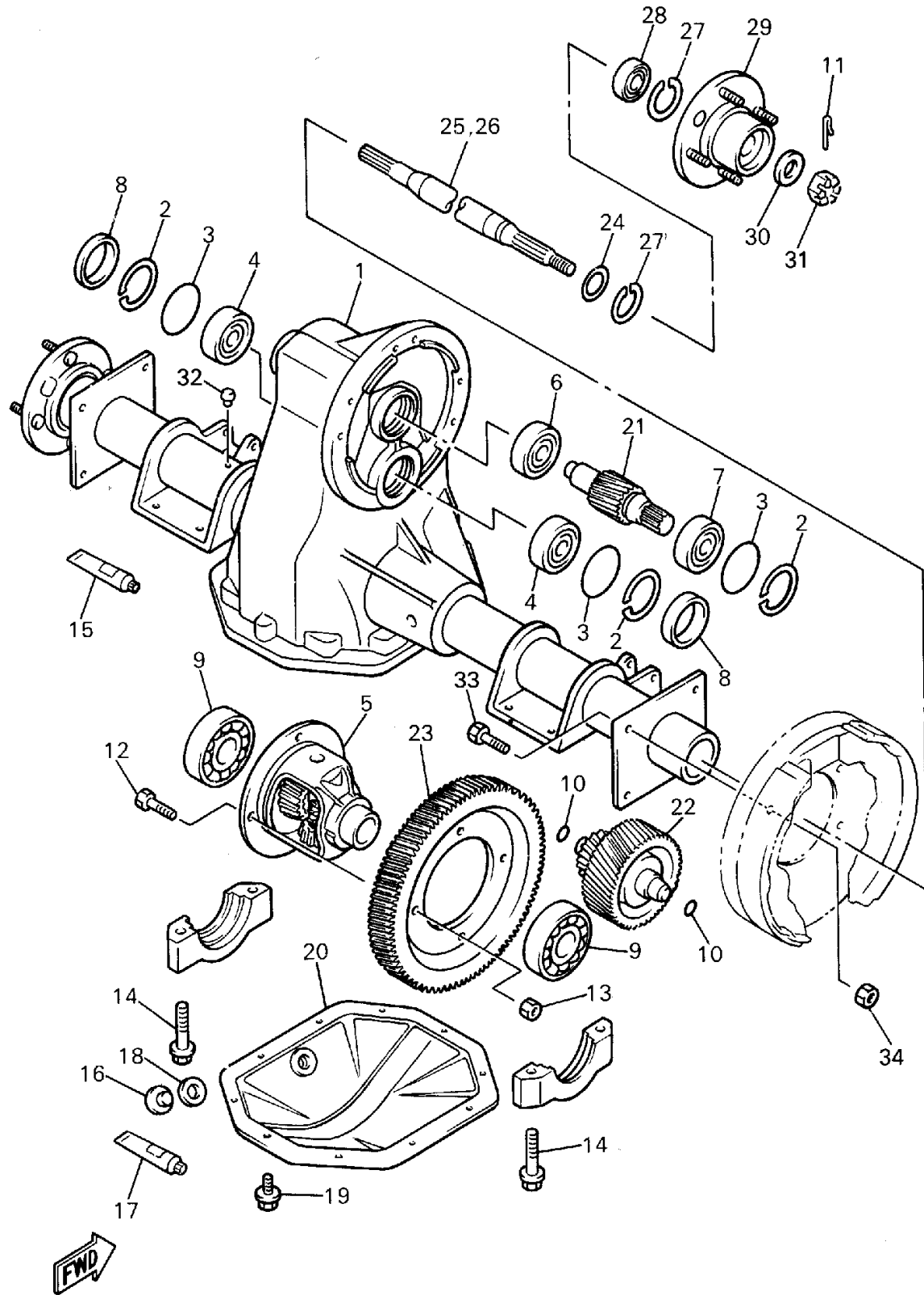

Ref. No.	Part Number	Description	Qty	Remarks
1	JH7-G6310-00-00	CASE ASSEMBLY	1	YPAD SEE NOTE
2	93420-50804-00	CIRCLIP	3	YPAD SEE NOTE
3	93210-478B8-00	RING	3	YPAD SEE NOTE
4	93306-303Y6-00	BEARING	2	YPAD SEE NOTE
5	JH7-G6410-00-00	DIFFERENTIAL ASSEMBLY	1	YPAD SEE NOTE
6	93306-203X1-00	BEARING	1	YPAD SEE NOTE
7	93306-005Y1-00	BEARING	1	YPAD SEE NOTE
8	JH7-G3396-00-00	PLUG, BLIND	2	YPAD SEE NOTE
9	93306-007Y0-00	BEARING	2	YPAD SEE NOTE
10	93210-148B9-00	O-RING	2	YPAD SEE NOTE
11	91490-25030-00	PIN, COTTER	2	YPAD SEE NOTE
12	90101-10854-00	BOLT, HEX.	4	YPAD SEE NOTE
13	90170-10840-00	NUT, HEX.	4	YPAD SEE NOTE
14	90105-10840-00	BOLT, FLANGE	4	YPAD SEE NOTE
15	ACC-11001-31-00	SEALANT 2 (JH7-G6137-00-00)	1	YPAD SEE NOTE
16	JH7-G5341-00-00	PLUG, DRAIN	1	YPAD SEE NOTE
17	ACC-11001-05-01	SEALANT 1 (JH7-G6136-00-00)	1	YPAD SEE NOTE
18	90201-158E0-00	WASHER, PLATE	1	YPAD SEE NOTE
19	90101-08856-00	BOLT, HEX.	10	YPAD SEE NOTE
20	JH7-G6312-00-00	CASE, TRANSMISSION 2	1	YPAD SEE NOTE
21	JH7-G6321-00-00	SHAFT, INPUT	1	YPAD SEE NOTE
22	JH7-G6350-00-00	COUNTER GEAR	1	YPAD SEE NOTE
23	JH7-G6421-00-00	GEAR, RING	1	YPAD SEE NOTE
24	93101-24822-00	SEAL, OIL	2	YPAD SEE NOTE
25	JH7-G6512-00-00	SHAFT, REAR AXLE 2 (RH)	1	YPAD SEE NOTE
26	JH7-G6511-00-00	SHAFT, REAR AXLE 1 (LH)	1	YPAD SEE NOTE
27	93420-44805-00	CIRCLIP	4	YPAD SEE NOTE
28	93306-004X5-00	BEARING	2	YPAD SEE NOTE
29	JH7-G6514-00-00	HUB, REAR AXLE	2	YPAD SEE NOTE

CONTINUED ON NEXT FRAME ➤

JH7110-3220

TRANSAXLE ASSEMBLY

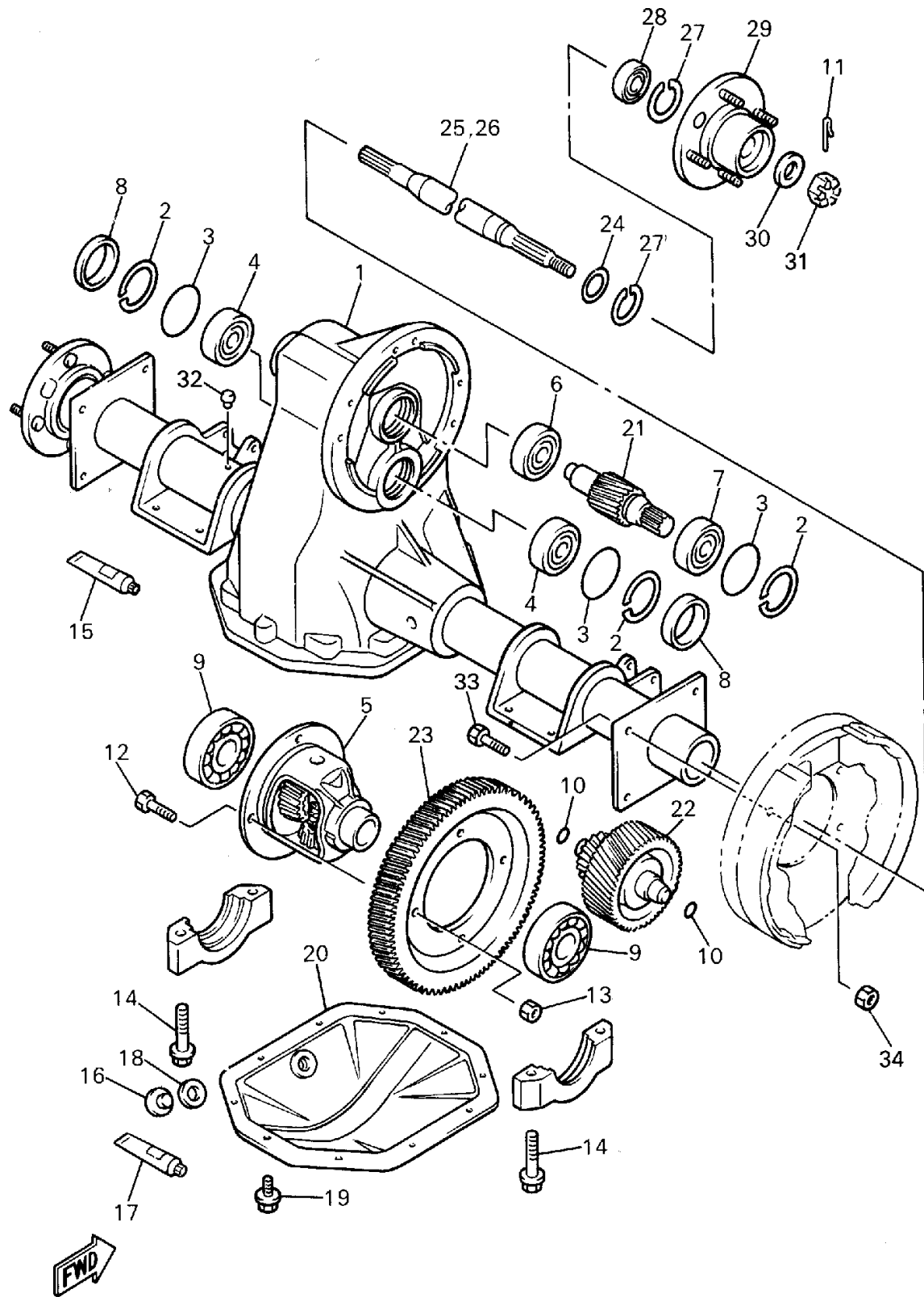

Ref. No.	Part Number	Description	Qty	Remarks
30	90201-198E1-00	WASHER	2	YPAD SEE NOTE
31	90171-16813-00	NUT	2	YPAD SEE NOTE
32	JH7-G5619-00-00	CAP	1	YPAD SEE NOTE
33	90101-08855-00	BOLT, HEX.	8	YPAD SEE NOTE
34	90170-08841-00	NUT, HEX.	8	YPAD SEE NOTE

JH7110-3220

TRANSMISSION 1

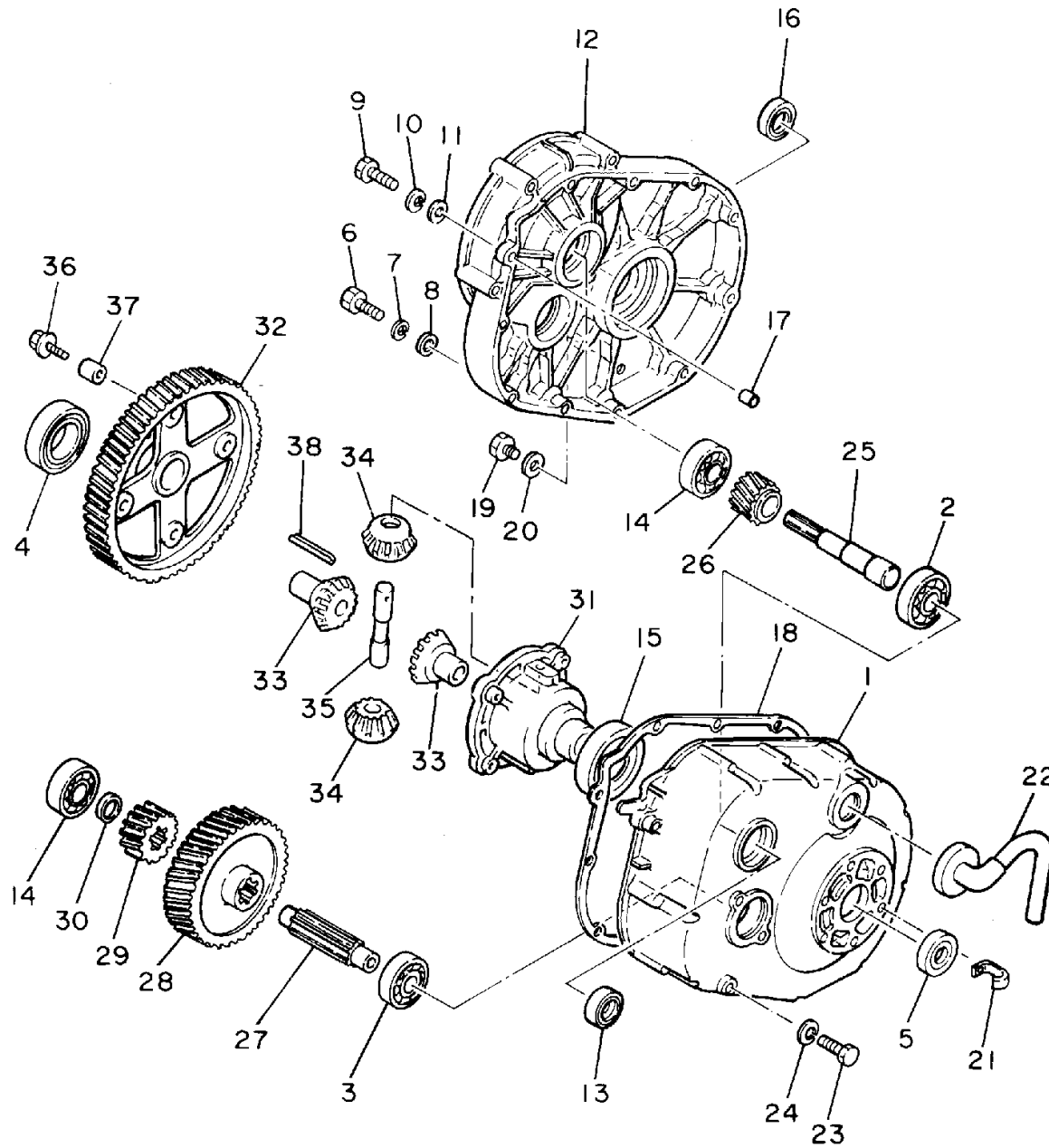

Ref. No.	Part Number	Description	Qty	Remarks
1	J14-46311-00-00	CASE, TRANSMISSION 1	1	SEE NOTE
2	93306-20541-00	BEARING (B6205)	1	SEE NOTE
3	93306-20421-00	BEARING	1	SEE NOTE
4	93306-00803-00	BEARING (B6008)	1	SEE NOTE
5	93102-22189-00	OIL SEAL	1	SEE NOTE
6	97021-08035-00	BOLT	9	SEE NOTE
7	92990-08100-00	WASHER	9	SEE NOTE
8	92901-08600-00	WASHER	9	SEE NOTE
9	97021-08045-00	BOLT	2	SEE NOTE
10	92990-08100-00	WASHER	2	SEE NOTE
11	92901-08600-00	WASHER	2	SEE NOTE
12	J14-46312-02-00	CASE, TRANSMISSION 2	1	SEE NOTE
13	93102-20143-00	OIL SEAL	1	SEE NOTE
14	93306-20421-00	BEARING	2	SEE NOTE
15	93306-00803-00	BEARING (B6008)	1	SEE NOTE
16	93102-22189-00	OIL SEAL	1	SEE NOTE
17	99510-12016-00	PIN, DOWEL	2	SEE NOTE
18	J10-46319-01-00	GASKET	1	SEE NOTE
19	90340-14036-00	PLUG, STRAIGHT SCRW	2	SEE NOTE
20	90430-14043-00	GASKET	2	SEE NOTE
21	90465-06100-00	CLAMP	1	SEE NOTE
22	835-47559-00-00	CAP 2	1	SEE NOTE
23	97011-10020-00	BOLT	2	SEE NOTE
24	92901-10100-00	WASHER, SPRING	2	SEE NOTE
25	J14-46321-01-00	SHAFT, INPUT	1	SEE NOTE
26	J56-46331-00-00	GEAR, INPUT 1	1	SEE NOTE
27	J10-46351-00-00	SHAFT, COUNTER	1	SEE NOTE
28	J56-46361-00-00	GEAR, COUNTER 1	1	SEE NOTE
29	J17-46362-00-00	GEAR, COUNTER 2	1	SEE NOTE

CONTINUED ON NEXT FRAME ➤



JH7100-3090

TRANSMISSION 1

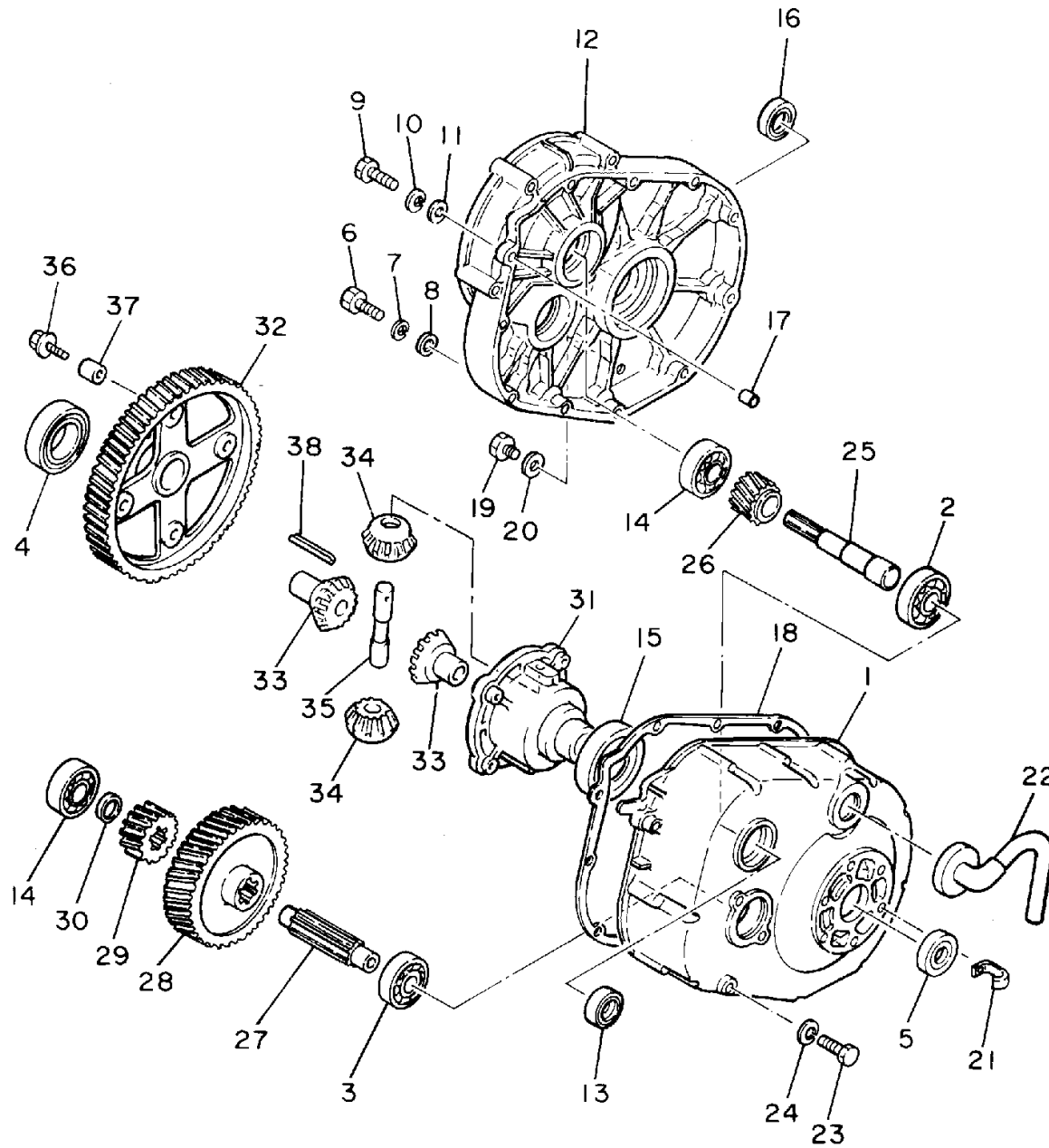

Ref. No.	Part Number	Description	Qty	Remarks
30	90201-20272-00	WASHER, PLATE	1	SEE NOTE
31	J38-46411-01-00	CASE, DIFFERENTIAL	1	SEE NOTE
32	J41-46421-00-00	GEAR, RING	1	SEE NOTE
33	J38-46414-00-00	GEAR, DIFFERENTIAL SIDE ..	2	SEE NOTE
34	J38-46415-00-00	PINION, DIFFERENTIAL	2	SEE NOTE
35	J38-46417-02-00	PIN, DIFFERENTIAL	1	SEE NOTE
36	90105-08390-00	BOLT, WASHER BASED	4	SEE NOTE
37	91812-16001-00	PIN, DOWEL	2	SEE NOTE
38	91609-40040-00	PIN, SPRING	1	SEE NOTE



JH7100-3090

REAR WHEEL

Ref. No.	Part Number	Description	Qty	Remarks
1	J55-G6521-00-00	DRUM	2	YPAD
2	JG5-F5100-10-00	REAR WHEEL ASSEMBLY ...	2	YPAD
3	90179-12262-00	NUT	8	
4	J17-25118-00-00	COVER, HUB DUST	2	

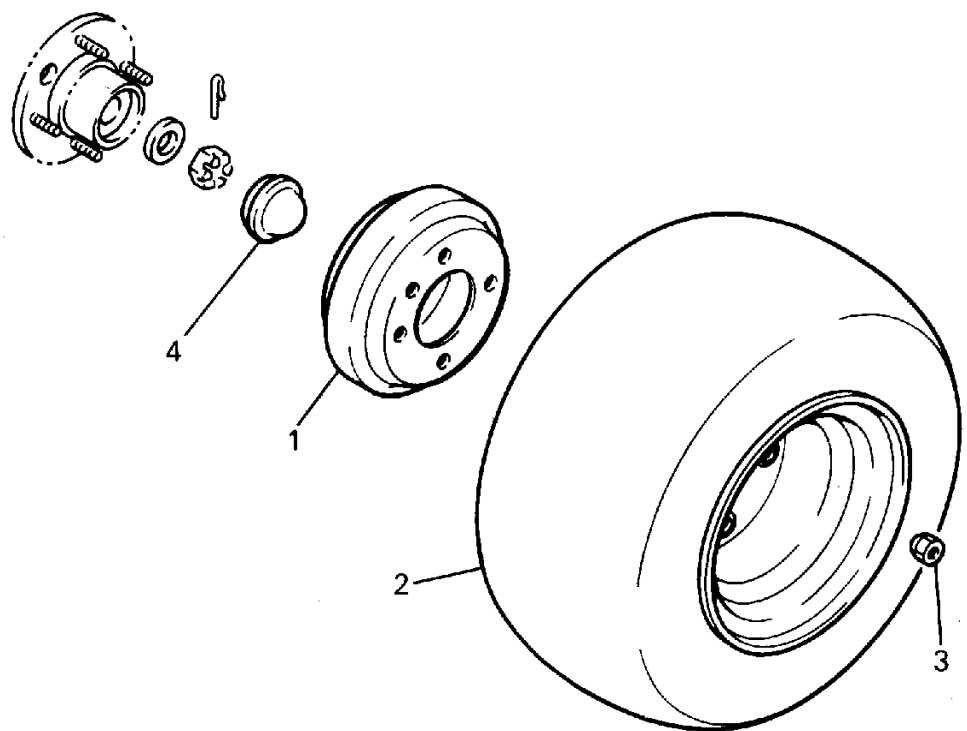

JH7100-4100

REAR AXLE - WHEEL

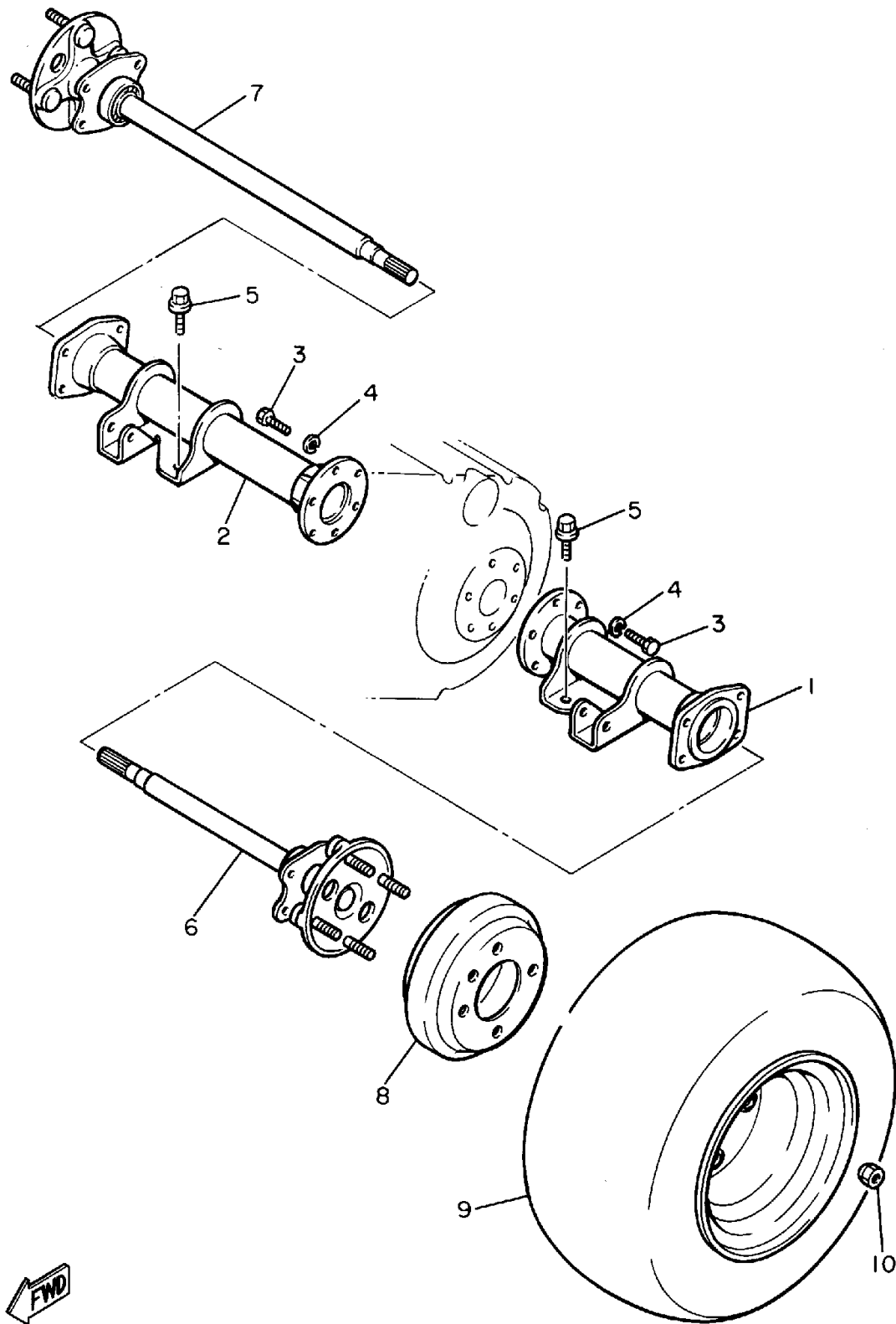

Ref. No.	Part Number	Description	Qty	Remarks
1	J41-46540-01-00	REAR AXLE HOUSING COMP.	1	SEE NOTE
2	J41-46550-01-00	REAR AXLE HOUSING COMP. 2	1	SEE NOTE
3	97011-08025-00	BOLT	12	SEE NOTE
4	92902-08100-00	WASHER, SPRING	12	SEE NOTE
5	95811-10020-00	BOLT, FLANGE (95822-10020-00)	8	SEE NOTE
6	J41-46510-00-00	REAR AXLE SHAFT COMP. ...	1	SEE NOTE
7	J41-46520-00-00	REAR AXLE SHAFT COMP. 2	1	SEE NOTE
8	J55-G6521-00-00	DRUM	2	SEE NOTE
9	JG5-F5100-10-00	REAR WHEEL ASSEMBLY ...	2	SEENOTE
10	90179-12262-00	NUT	8	SEE NOTE
6-1	90114-12004-00	. BOLT, RIBBED NECK	4	SEE NOTE
7-1	90114-12004-00	. BOLT, RIBBED NECK	4	SEE NOTE



J41100-7090

BUMPER

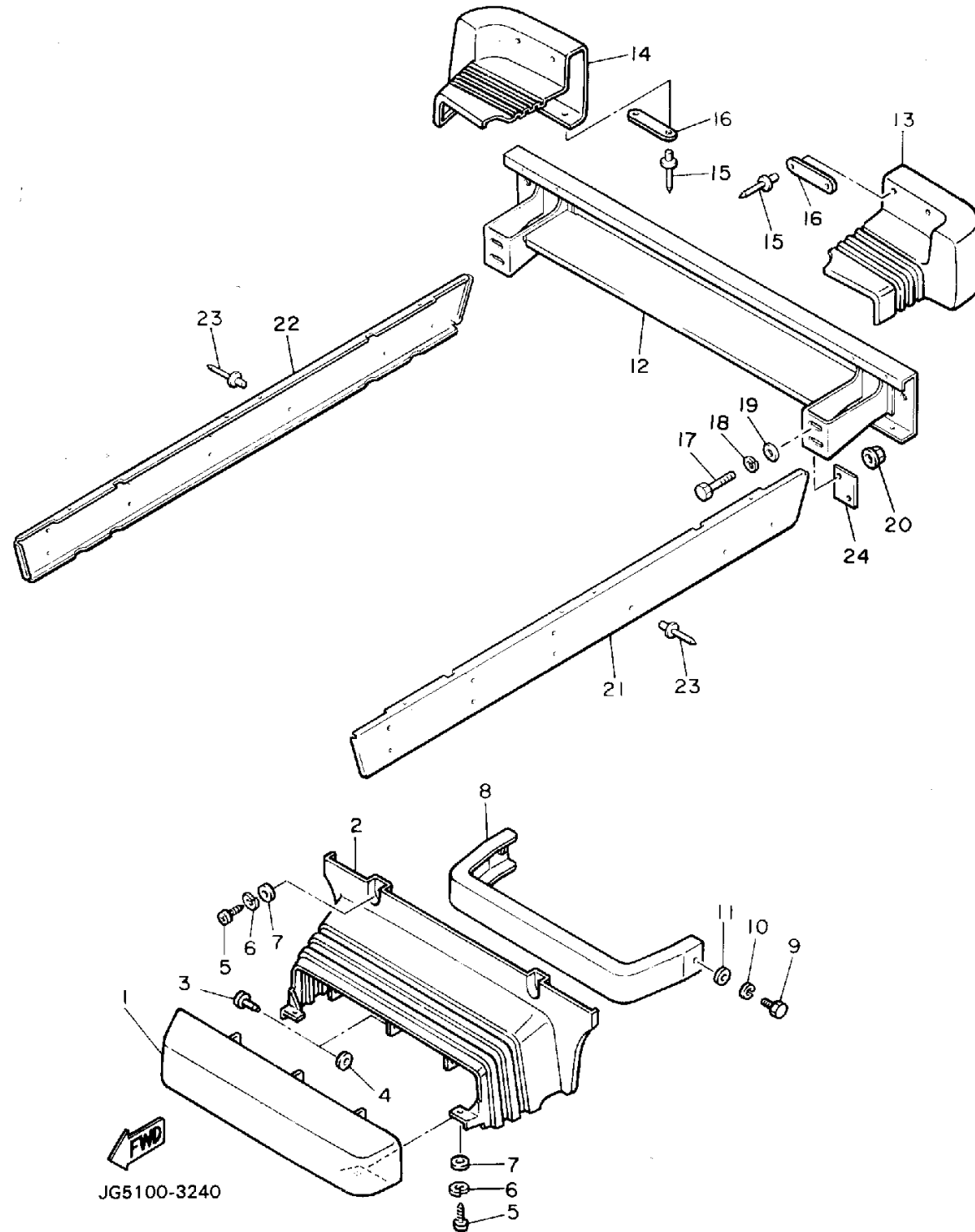

JG5100-3240

Ref. No.	Part Number	Description	Qty	Remarks
1	J55-K8162-00-00	PAD, FRONT BUMPER	1	YPAD
2	J55-K8163-00-00	COVER, BUMPER	1	YPAD
3	90269-06028-00	RIVET	3	
4	90201-076J4-00	WASHER, PLATE	3	
5	98506-05020-00	SCREW, PAN HEAD	4	
6	92906-05100-00	WASHER, SPRING	4	
7	90201-05033-00	WASHER, PLATE	4	
8	J55-K7511-00-00	BUMPER, FRONT 1	1	YPAD
9	97011-08016-00	BOLT	2	
10	92902-08100-00	WASHER, SPRING	2	
11	92990-08600-00	WASHER, PLATE	2	
12	JG5-K8107-00-00	BUMPER SUB-ASSEMBLY, REAR	1	YPAD
13	J55-K8167-00-00	BUMPER, RUBBER 1	1	YPAD
14	J55-K8168-00-00	BUMPER, RUBBER 2	1	YPAD
15	90267-40077-00	RIVET, BLIND	8	
16	J17-77525-00-00	WASHER 1	4	
17	97026-08050-00	BOLT	4	
18	92906-08100-00	WASHER, SPRING	4	
19	92906-08600-00	WASHER	4	
20	95706-08500-00	NUT, flange	4	
21	JG5-K8183-00-00	PLATE, SIDE SILL (L.H)	1	YPAD
22	JG5-K8184-00-00	PLATE, SIDE SILL (R.H)	1	YPAD
23	90267-48838-00	RIVET	18	YPAD
24	G9E-PARTS-BO-AR JG5-K7527-00-00	ASSEMBLY, HARDWARE PLATE, BACK UP	9 2	OPTIONAL PART YPAD

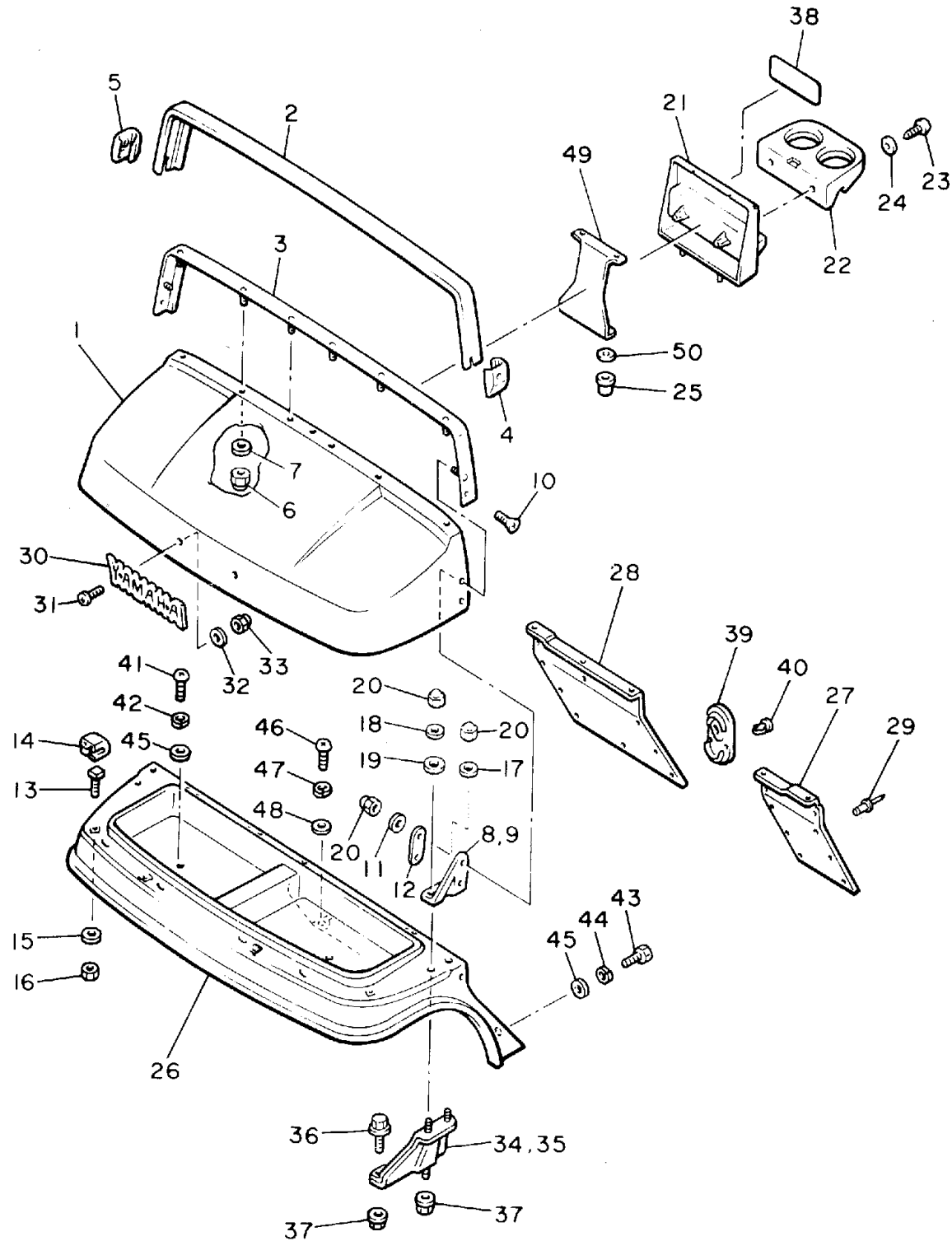

BODY

Ref. No.	Part Number	Description	Qty	Remarks
1	J55-K8116-00-00	COWL, FRONT UPPER	1	YPAD
2	JG5-K811V-00-00	PROTECTOR 1	1	YPAD
3	JG5-K8261-01-00	PLATE, BODY PROTECT 1 (JG5-K8261-00-00)	1	YPAD
4	JG5-K818E-00-00	CAP, PROTECTOR END 1	1	YPAD
5	JG5-K818F-00-00	CAP, PROTECTOR END 2	1	YPAD
6	95601-06200-00	NUT, U FLANGE	6	
7	90201-06059-00	WASHER, PLATE	6	
8	JG5-K811E-00-00	STAY, UPPER COWL (LH)	1	YPAD
9	JG5-K811F-00-00	STAY, UPPER COWL (RH)	1	YPAD
10	90151-06803-00	SCREW, COUNTERSUNK	2	YPAD
11	92990-06200-00	WASHER	4	
12	JG5-K8117-00-00	PLATE 1	2	YPAD
13	J38-7811G-00-00	BOLT, COWL FITTING	4	
14	J38-7811H-00-00	RETAINER, COWL FITTING	4	
15	90201-065F3-00	WASHER, PLATE	4	
16	95601-06100-00	NUT, U	4	
17	90201-062G3-00	WASHER, PLATE	2	
18	92990-06200-00	WASHER	2	
19	90202-06172-00	WASHER, PLATE	2	
20	J55-K811B-00-00	NUT, CAP	8	YPAD
21	JG5-K835G-00-00	HOUSING, HOLDER	1	YPAD
22	JF2-K835E-00-00	HOLDER, BEVERAGE	1	YPAD
23	97702-60130-00	SCREW, TAPPING	2	
24	90201-060A3-00	WASHER, PLATE	2	
25	90480-12355-00	GROMMET	2	
26	JG5-K8115-00-00	COWL, FRONT	1	YPAD
27	JG5-K8231-00-00	MAT, MAIN FLOOR 1	1	YPAD
28	JG5-K8232-00-00	MAT, MAIN FLOOR 2	1	YPAD

CONTINUED ON NEXT FRAME ►



JH7100-3120

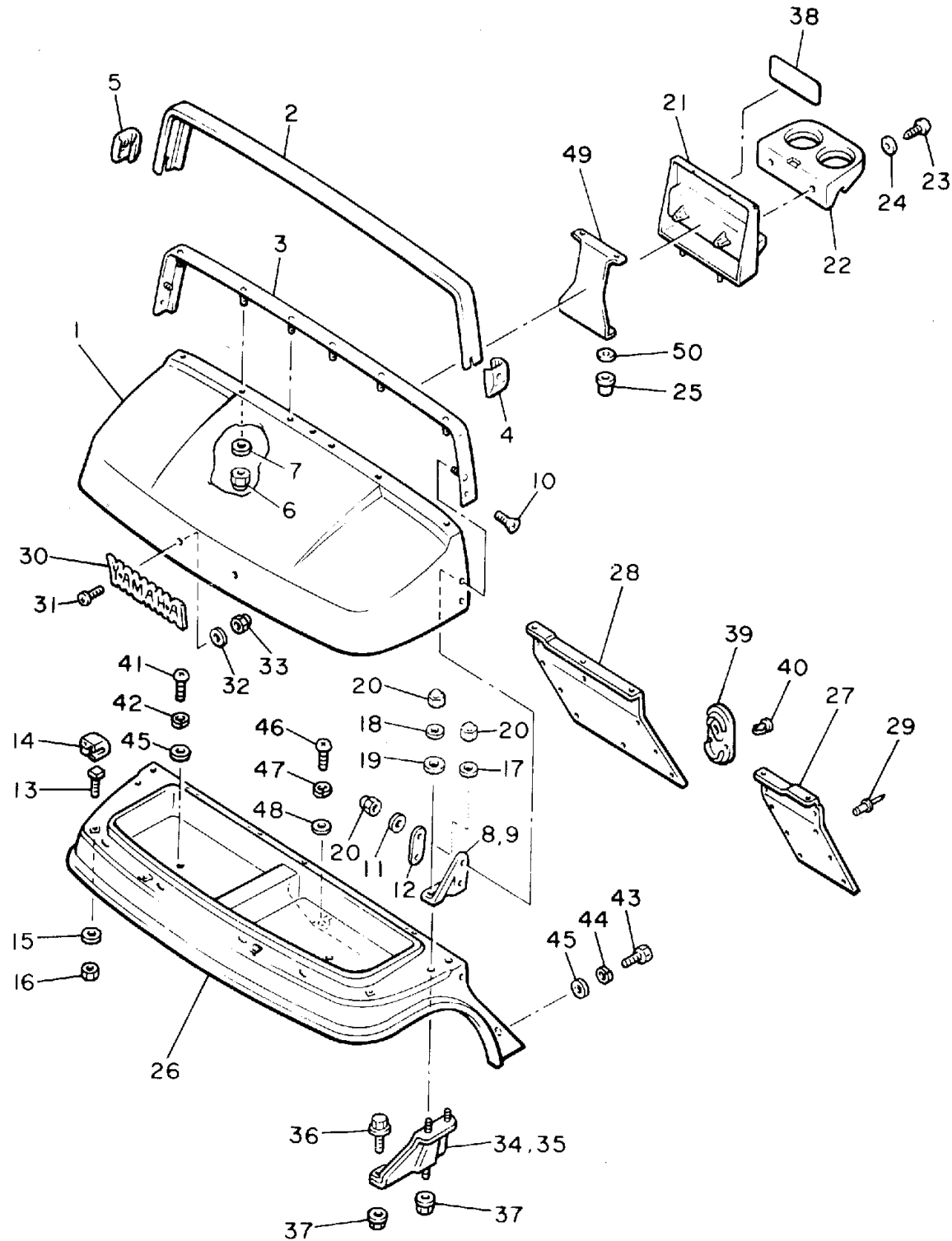

JH7100-3120

G9-EKP

BODY

Ref. No.	Part Number	Description	Qty	Remarks
29	90267-63047-00	RIVET, BLIND	16	
30	J38-24161-00-00	EMBLEM 1	1	
31	90152-04015-00	SCREW, COUNTERSUNK	2	
32	92906-04200-00	WASHER, PLAIN	2	
33	95606-04100-00	NUT, U	2	
34	J38-7812E-01-00	SUPPORT, UPPER COWL (L.H)	1	
35	J38-7812F-01-00	SUPPORT, UPPER COWL (R.H)	1	
36	95811-08016-00	BOLT, FLANGE	2	
37	95701-08500-00	NUT, FLANGE	4	
38	JH7-K7768-00-00	LABEL, WARNING 2	1	UR
39	J38-78273-00-00	COVER, HOLE	1	
40	90269-11042-00	RIVET	2	
41	98580-06020-00	SCREW	2	
42	92995-06100-00	WASHER, SPRING	2	
43	97595-06520-00	BOLT, WITH WASHER	2	
44	92995-06100-00	WASHER, SPRING	2	
45	90201-067M9-00	WASHER, PLATE	4	
46	98580-06020-00	SCREW	1	
47	92995-06100-00	WASHER, SPRING	1	
48	90201-06049-00	WASHER, PLATE	1	
49	JG5-K834A-00-00	REING., HOLDER	1	YPAD
50	90183-06071-00	NUT, SPRING	2	

BODY 2

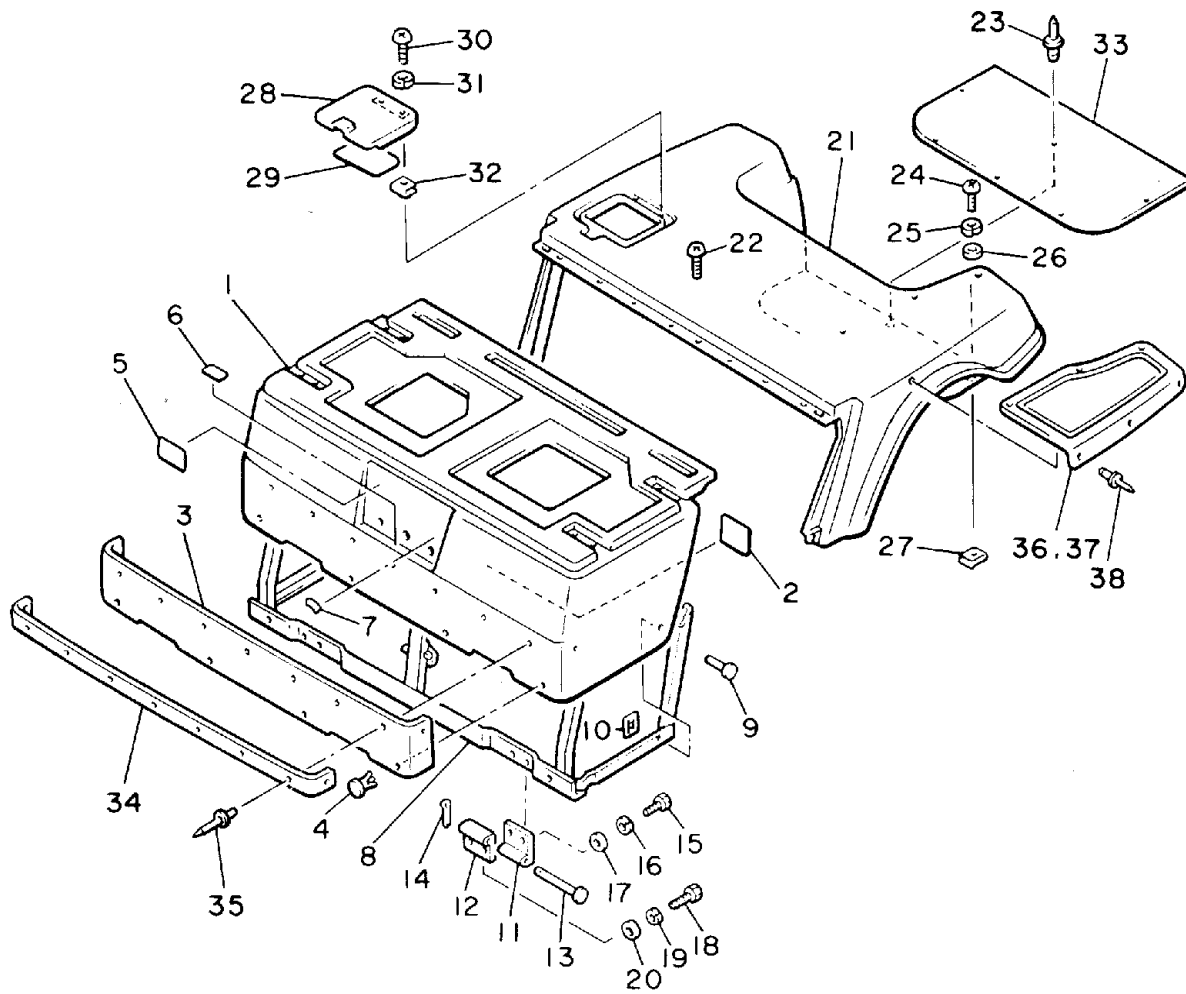

Ref. No.	Part Number	Description	Qty	Remarks
1	J55-K8141-00-00	PANEL, INTERMEDIATE BODY	1	YPAD
2	JH7-K7765-00-00	LABEL, WARNING 5	1	YPAD
3	JG5-K814N-00-00	PLATE, ORNAMENT	1	YPAD
4	90267-63047-00	RIVET, BLIND	4	
5	J41-77458-10-00	LABEL, WARNING (J41-77458-00-00)	1	
6	J38-77741-10-00	INDICATOR 1	1	
7	J38-77742-00-00	INDICATOR 2	1	
8	JG6-K8121-00-00	REINFORCEMENT 1	1	YPAD
9	90338-06169-00	PLUG	2	
10	90183-06071-00	NUT, SPRING	2	
11	J55-K8143-00-00	HINGE, INTERMEDIATE BODY 1	2	YPAD
12	J55-K8144-00-00	HINGE, INTERMEDIATE BODY 2	2	YPAD
13	91790-06125-00	PIN, CLEVIS	2	
14	91490-20015-00	PIN, COTTER	2	
15	97013-06012-00	BOLT	4	
16	92995-06100-00	WASHER, SPRING	4	
17	92990-06600-00	WASHER, PLATE	4	
18	97011-06020-00	BOLT	4	
19	92995-06100-00	WASHER, SPRING	4	
20	92990-06600-00	WASHER, PLATE	4	
21	J55-K8142-00-00	PANEL, REAR BODY	1	YPAD
22	95811-06020-00	BOLT, FLANGE	3	
23	90267-63047-00	RIVET, BLIND	6	
24	98580-06020-00	SCREW	2	
25	92995-06100-00	WASHER, SPRING	2	
26	90201-065F3-00	WASHER, PLATE	2	
27	90183-06028-00	NUT, SPRING	2	



JH7100-3130

CONTINUED ON NEXT FRAME ►

BODY 2

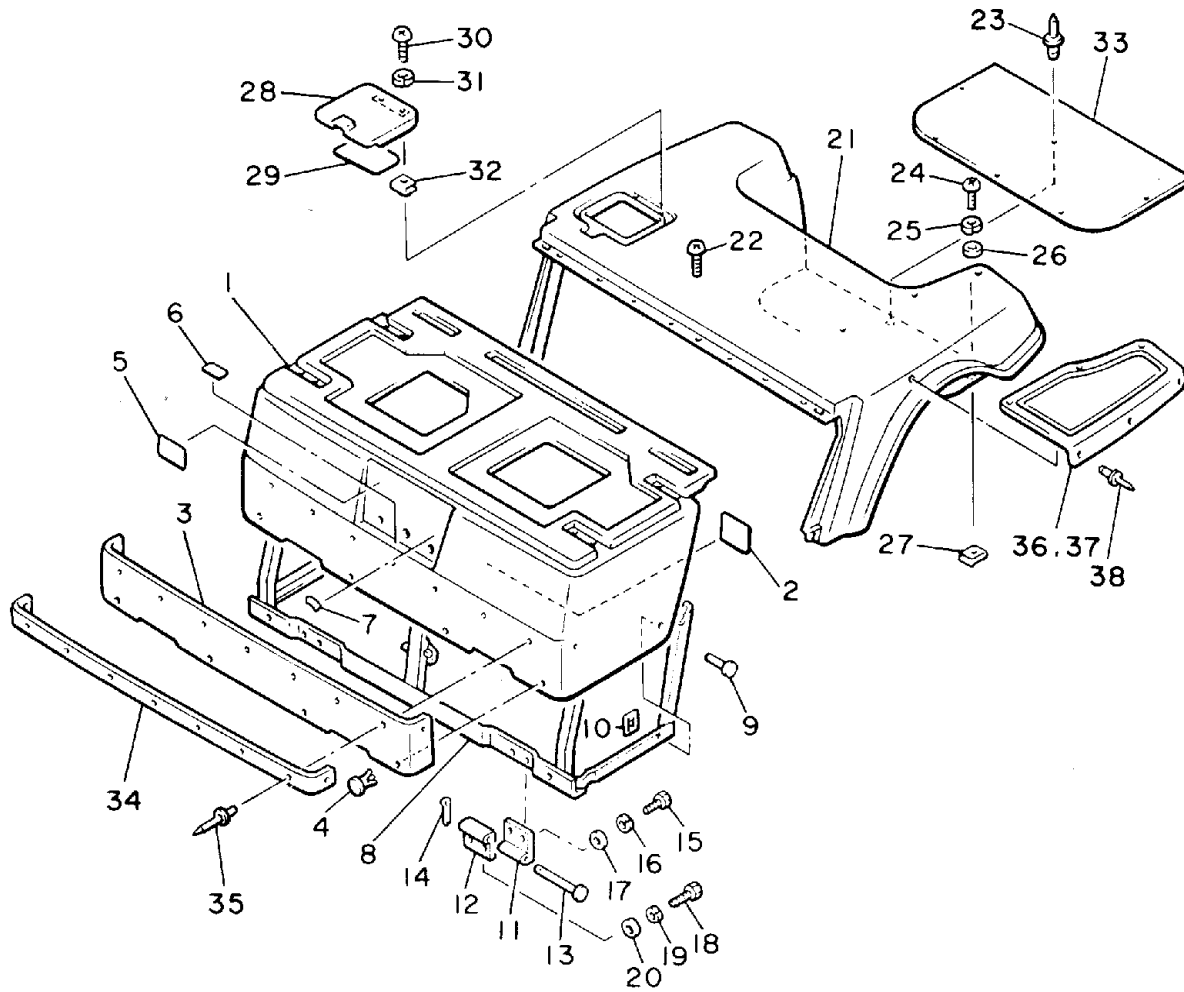

Ref. No.	Part Number	Description	Qty	Remarks
28	J55-K8272-00-00	COVER, FUEL INLET	1	YPAD
29	J51-77764-00-00	LABEL, WARNING 4	1	UR
30	98511-04012-00	SCREW, PAN HEAD	2	
31	92901-04100-00	WASHER, SPRING	2	
32	J38-78276-00-00	NUT, INLET FITTING	2	
33	JG5-K8241-00-00	MAT, REAR FLOOR	1	YPAD
34	JG5-K824E-01-00	TRIM, REAR BODY (LH)	1	YPAD
35	90267-41164-00	RIVET, BLIND	9	
36	J55-K8243-00-00	MAT, REAR BODY SIDE (LH) .	1	YPAD
37	J55-K8244-00-00	MAT, REAR BODY SIDE (RH) .	1	YPAD
38	90267-63047-00	RIVET, BLIND	12	
	G9E-PARTS-BO-AR	ASSEMBLY, HARDWARE	9	OPTIONAL PART



JH7100-3130

BODY FITTING

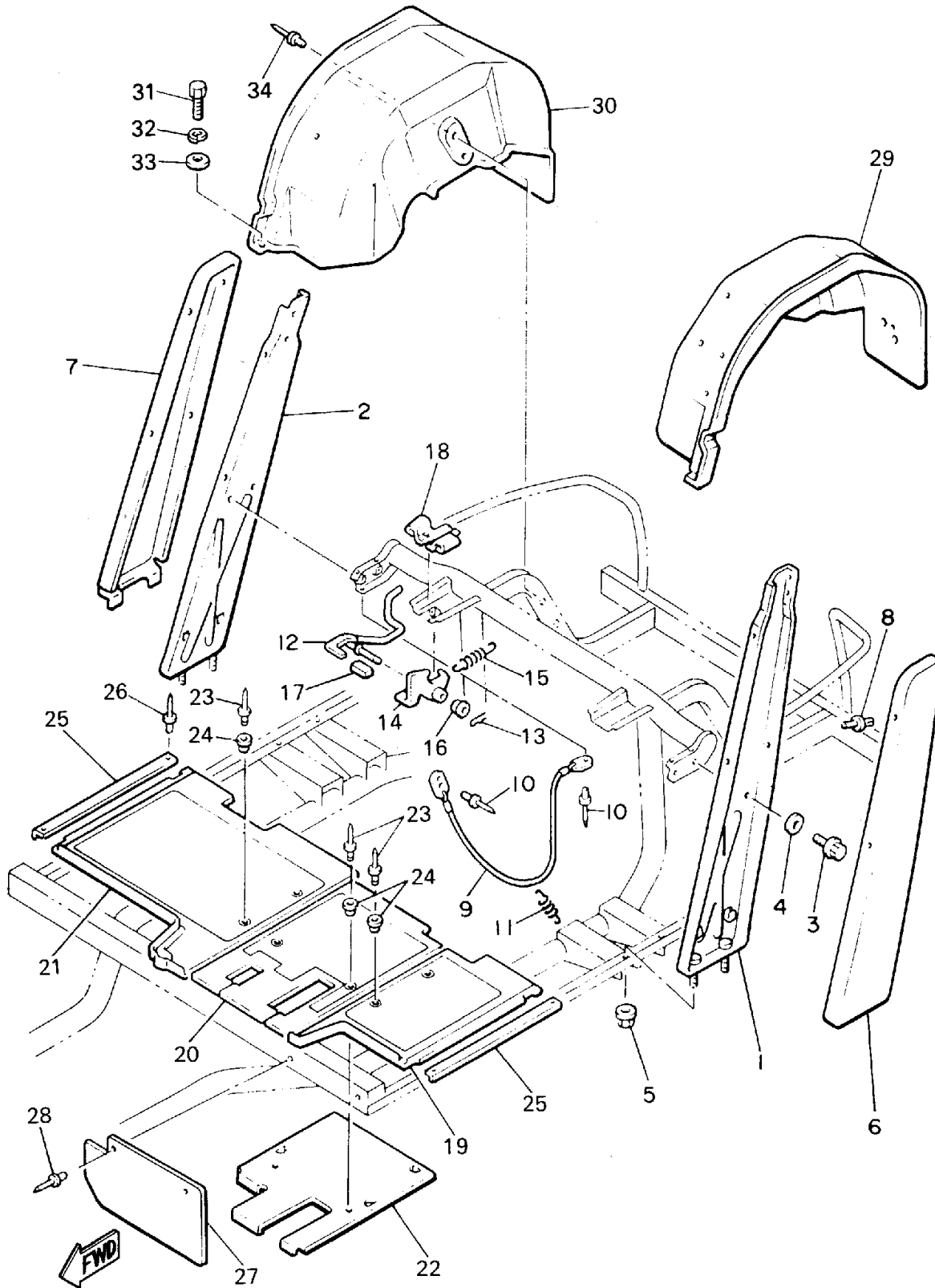

JH7100-4140

Ref. No.	Part Number	Description	Qty	Remarks
1	JG5-K813A-00-00	PILLAR, SIDE (L.H)	1	YPAD
2	JG5-K813E-00-00	PILLAR, SIDE (R.H)	1	YPAD
3	95811-08016-00	BOLT, FLANGE	4	
4	90201-08730-00	WASHER, PLATE	4	
5	95701-06500-00	NUT, FLANGE	4	
6	J55-K813F-00-00	COVER, SIDE PILLAR (L.H)	1	YPAD
7	J55-K813G-00-00	COVER, SIDE PILLAR (R.H)	1	YPAD
8	90267-63134-00	RIVET, BLIND	8	
9	J38-78229-00-00	WIRE, SEAT STOPPER	1	
10	90267-40105-00	RIVET, BLIND	2	
11	90507-08037-00	SPRING, TENSION	1	
12	JG5-K814G-00-00	LEVER, BODY LOCK	1	YPAD
13	90468-18008-00	CLIP	1	
14	J38-7814H-01-00	HOOK, BODY LOCK	1	
15	90506-18374-00	SPRING, TENSION	1	
16	J38-7814L-01-00	BUSH, LEVER END	2	
17	J38-7815H-00-00	DAMPER, LOCK	1	
18	J38-78221-00-00	SHEET, BODY MOUNTING 1	2	
19	J55-K8233-00-00	MAT, MAIN FLOOR 3	1	YPAD
20	J55-K8234-00-00	MAT, MAIN FLOOR 4	1	YPAD
21	J55-K8235-00-00	SHEET, MAIN FLOOR	1	YPAD
22	J55-K8271-00-00	SERVICE LID, PEDAL	1	YPAD
23	90267-48086-00	RIVET, BLIND	6	
24	90387-062M9-00	COLLAR	6	
25	J38-78215-00-00	PLATE, SIDE TRIM	2	
26	90267-40837-00	RIVET, BLIND	4	YPAD
27	JG5-K8187-00-00	FLAP, FRONT FENDER	2	YPAD
28	90267-48101-00	RIVET, BLIND	4	YPAD
29	JG5-K8191-00-00	PANEL, REAR FENDER 1	1	YPAD

CONTINUED ON NEXT FRAME ►

BODY FITTING

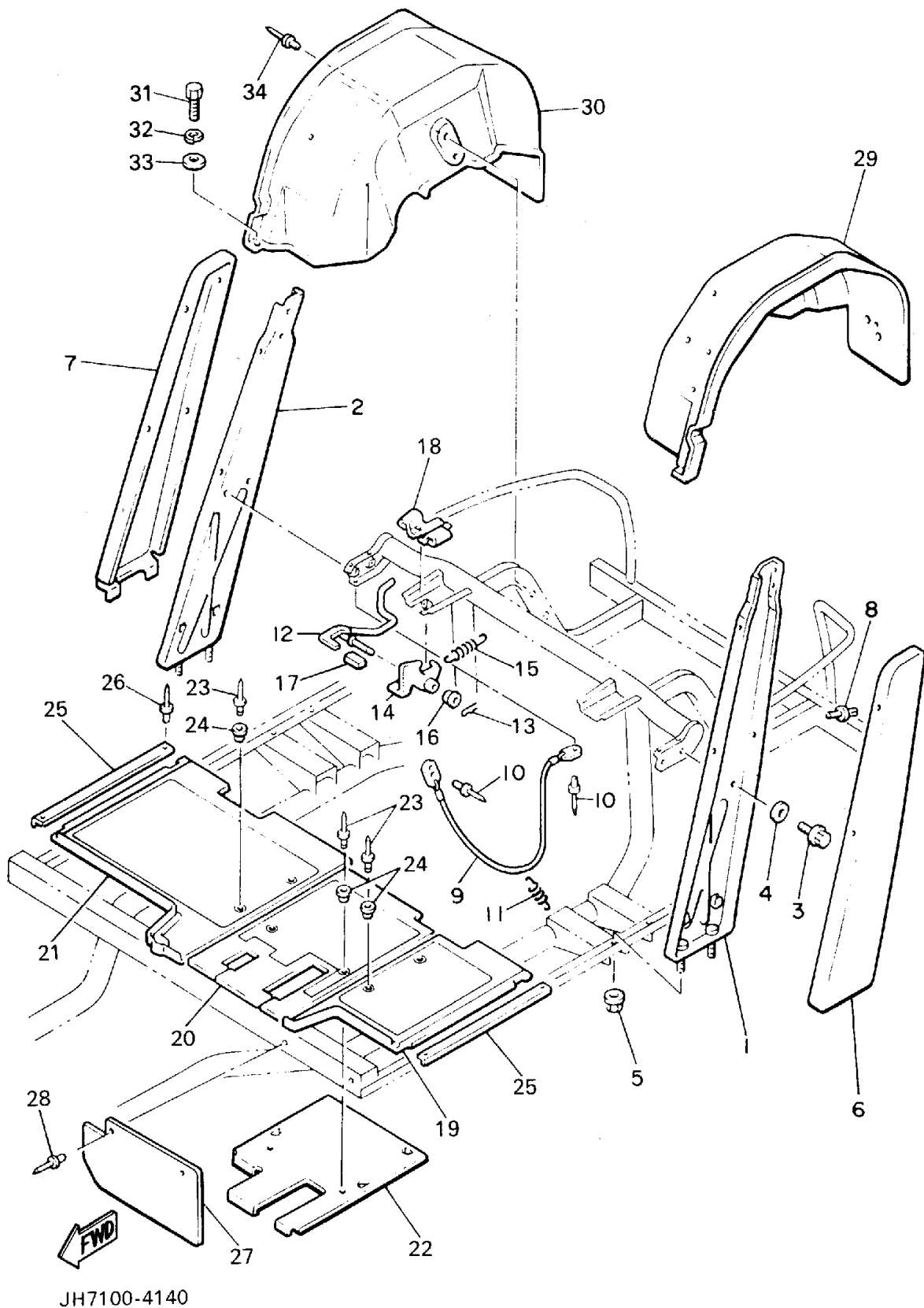

Ref. No.	Part Number	Description	Qty	Remarks
30	J55-K8192-00-00	PANEL, REAR FENDER 2	1	YPAD
31	97016-06016-00	BOLT	2	
32	92906-06100-00	WASHER, SPRING	2	
33	92906-06600-00	WASHER	2	
34	90267-48101-00	RIVET, BLIND	6	YPAD
	G9E-PARTS-BO-AR	ASSEMBLY, HARDWARE	9	OPTIONAL PART

CARRIER

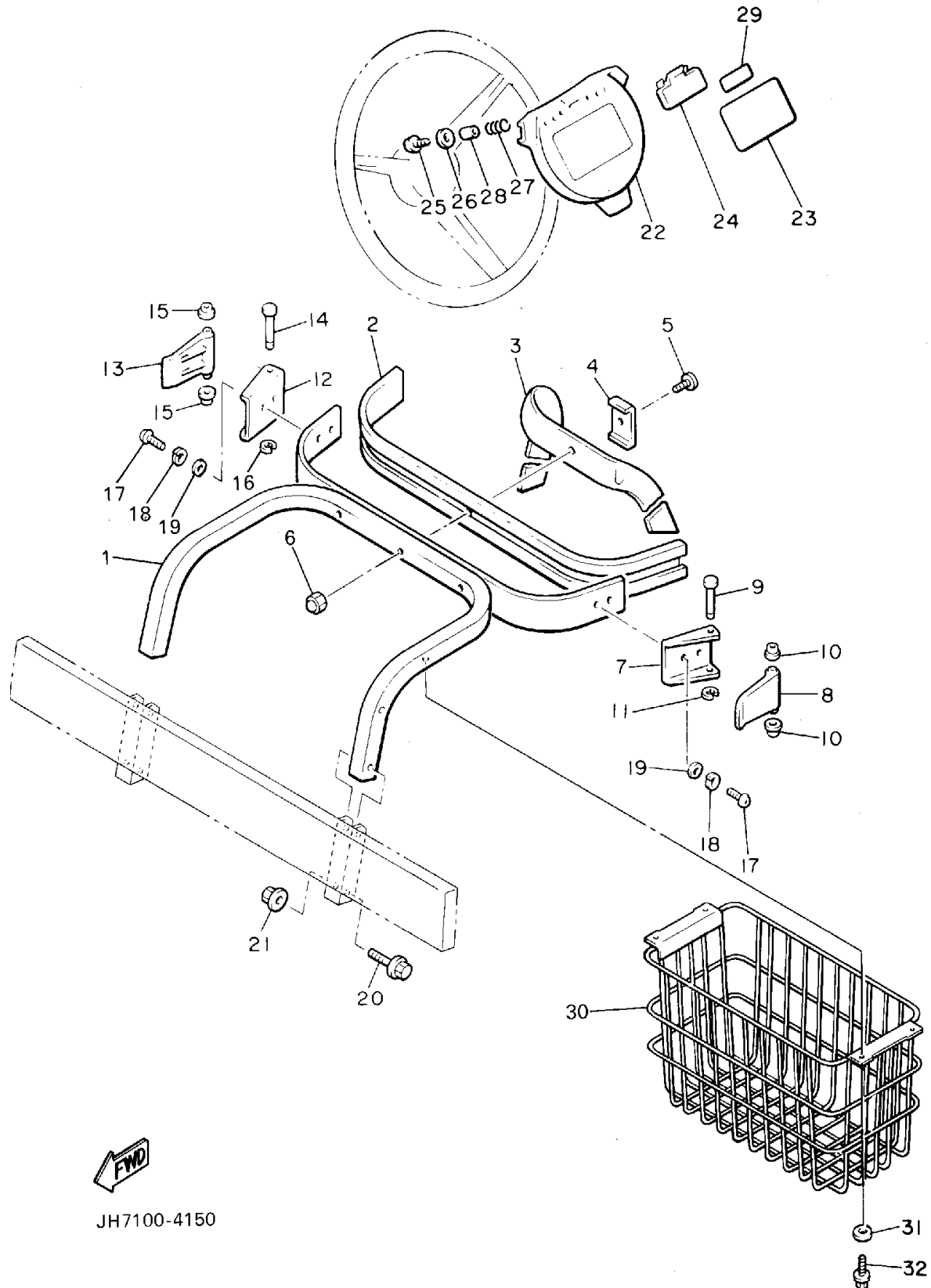

Ref. No.	Part Number	Description	Qty	Remarks
1	JG5-K8351-10-00	SUPPORT, BAG UPPER	1	YPAD
2	JF2-K8356-00-00	PAD, BAG SUPPORT	1	YPAD
3	J38-78355-00-00	BAND	1	
4	J38-78367-00-00	PLATE, ANCHOR	1	
5	98980-06016-00	SCREW, BINDING	1	
6	95380-06800-00	NUT	1	
7	J17-78157-01-00	BASE, LOCK	1	
8	J17-78368-01-00	LEVER, LOCK	1	
9	J17-78369-00-00	PIN, LEVER	1	
10	90386-06108-00	BUSH	2	
11	99080-05600-00	CIRCLIP	1	
12	J17-78157-01-00	BASE, LOCK	1	
13	J17-78368-01-00	LEVER, LOCK	1	
14	J17-78369-00-00	PIN, LEVER	1	
15	90386-06108-00	BUSH	2	
16	99080-05600-00	CIRCLIP	1	
17	98580-06010-00	SCREW, PAN HEAD (92503-06010)	4	
18	92995-06100-00	WASHER, SPRING	4	
19	92990-06200-00	WASHER	4	
20	95811-08040-00	BOLT, FLANGE	4	
21	95701-08500-00	NUT, FLANGE	4	
22	J55-K8357-00-00	HOLDER 1	1	YPAD
23	JH7-K7762-00-00	LABEL, WARNING 2	1	
24	J55-K8358-00-00	HOLDER 2	1	YPAD
25	97706-40525-00	SCREW, TAPPING	2	
26	90201-044H9-00	WASHER, PLAIN	2	
27	90502-10013-00	SPRING, CONICAL	2	
28	90387-046N7-00	COLLAR	2	

CONTINUED ON NEXT FRAME ►



JH7100-4150

CARRIER

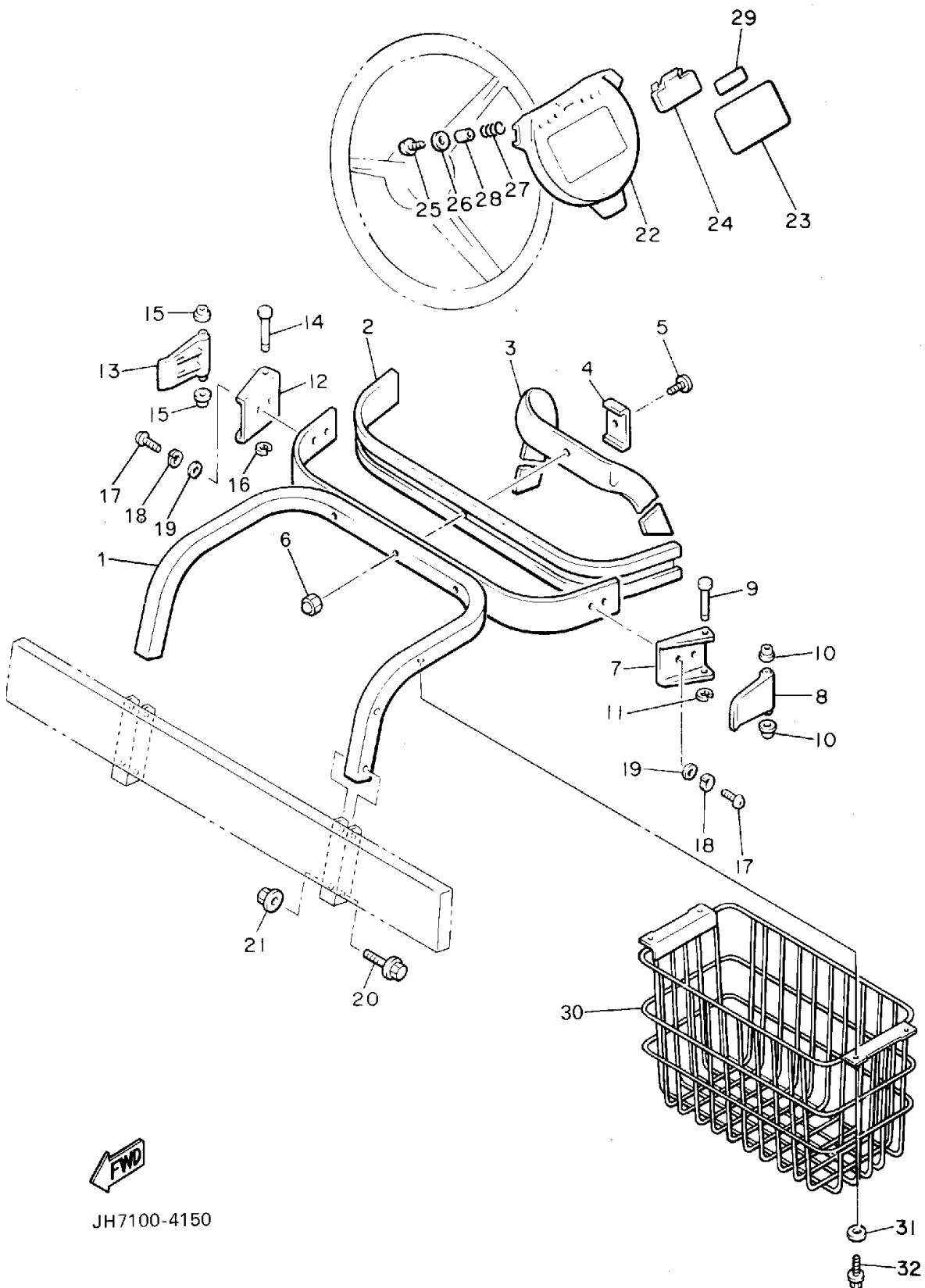
Ref. No.	Part Number	Description	Qty	Remarks
29	J51-77763-00-00	LABEL, WARNING 3	1	
30	JG5-K8340-00-00	LUGGAGE RACK ASSEMBLY, REAR	1	YPAD
31	90201-08103-00	WASHER, PLAIN	4	
32	95805-08016-00	BOLT, FLANGE	4	

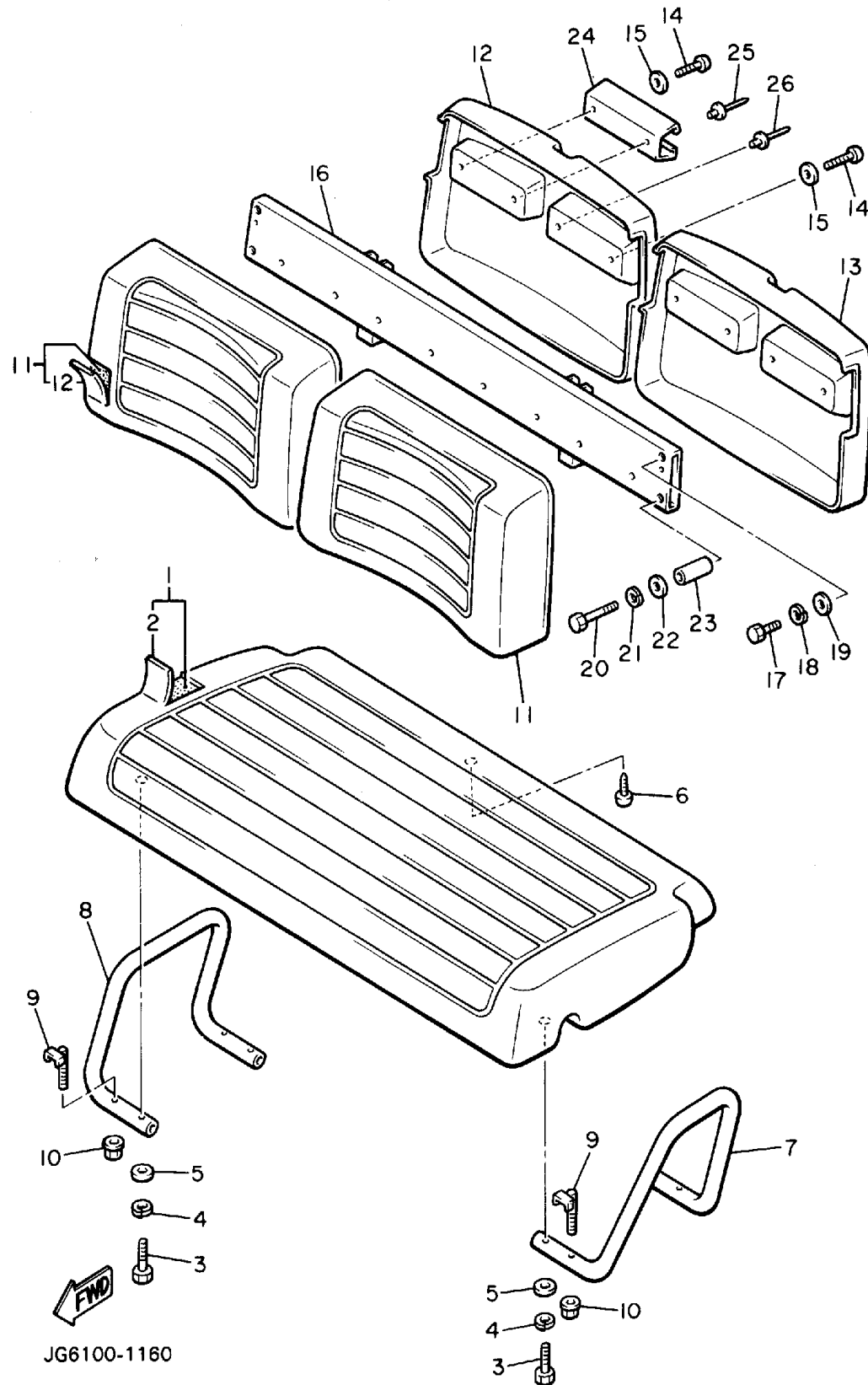

SEAT



Ref. No.	Part Number	Description	Qty	Remarks
1	JG5-K8401-00-00	SEAT SUB-ASSEMBLY, CUSHION	1	YPAD
2	JG5-K8404-09-00	. COVER, SEAT	1	YPAD
3	97021-08065-00	BOLT	4	
4	92902-08100-00	WASHER, SPRING	4	
5	92990-08600-00	WASHER, PLATE	4	
6	90149-059U1-00	SCREW, PANHEAD (97701-50516)	1	
7	JG5-K8361-01-00	ARM REST 1	1	YPAD
8	JG5-K8362-01-00	ARM REST 2	1	YPAD
9	J38-78384-00-00	BOLT	4	
10	95601-08200-00	NUT, U	4	
11	JG5-K8402-01-00	SEAT SUB ASSEMBLY, BACK	2	YPAD
12	JG5-K841G-09-00	. COVER, SUB-SEAT	1	YPAD
13	JG5-K8413-00-00	COVER, SEAT BACK	2	YPAD
14	98980-06045-00	SCREW, BIND	4	
15	90201-065F3-00	WASHER, PLATE	4	
16	JG5-K8423-01-00	SUPPORT, SEAT BACK	1	YPAD
17	97011-08016-00	BOLT	2	
18	92902-08100-00	WASHER, SPRING	2	
19	92990-08600-00	WASHER, PLATE	2	
20	97022-08075-00	BOLT	2	
21	92902-08100-00	WASHER, SPRING	2	
22	92990-08600-00	WASHER, PLATE	2	
23	90387-103G9-00	COLLAR	2	
24	J55-K835A-00-00	HOLDER, BALL	2	YPAD
25	90267-63047-00	RIVET, BLIND	2	
26	90267-63134-00	RIVET, BLIND	2	
	G9E-PARTS-BO-AR	ASSEMBLY, HARDWARE	9	OPTIONAL PART

ELECTRIC MOTOR

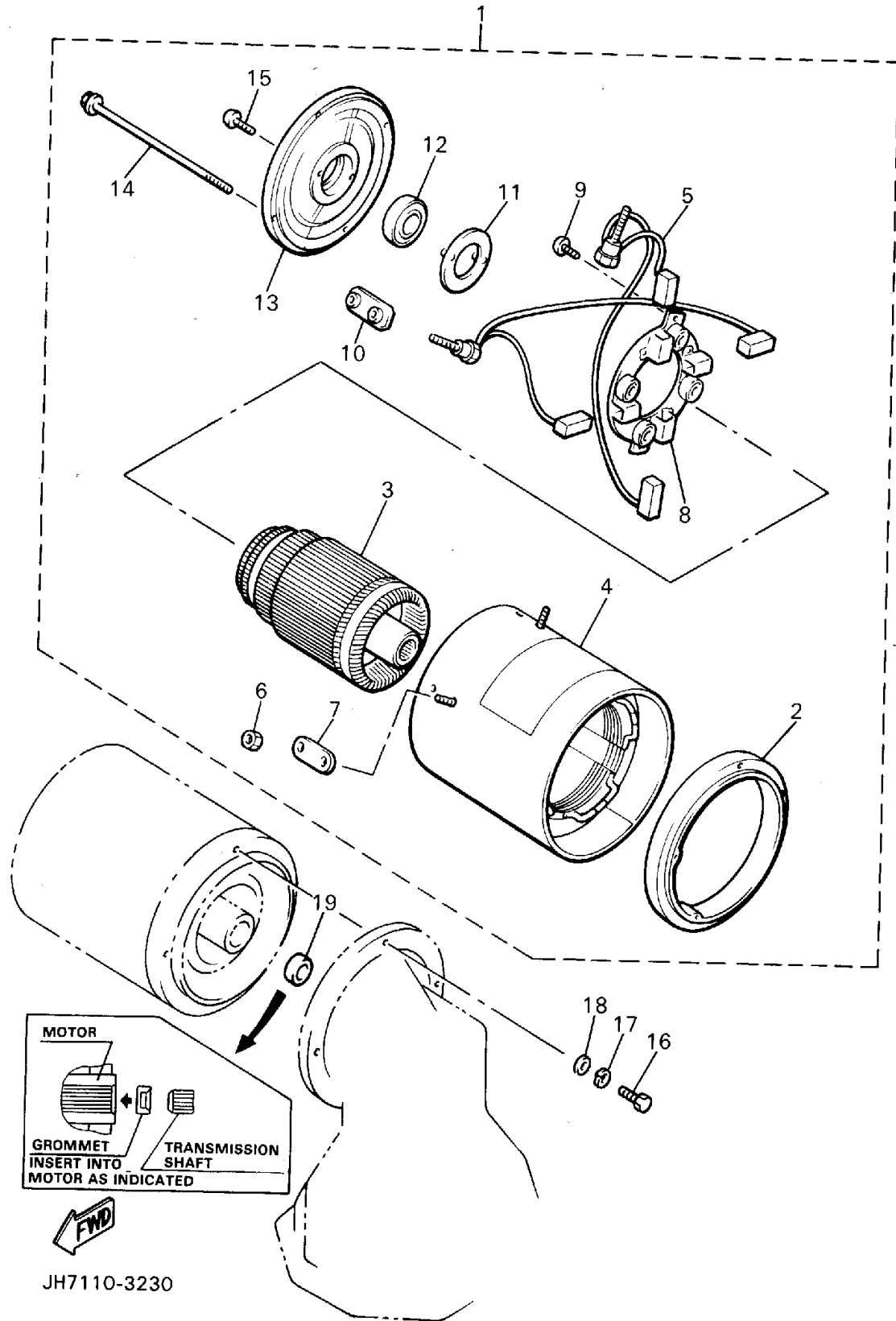

JH7110-3230

Ref. No.	Part Number	Description	Qty	Remarks
1	JH7-H1890-10-00	MOTOR ASSEMBLY	1	YPAD
2	JH7-H183J-00-00	. BRACKET, FRONT	1	YPAD
3	JH7-H1850-00-00	. ARMATURE ASSEMBLY	1	YPAD
4	JH7-H1810-10-00	. STATOR ASSEMBLY	1	YPAD
5	JH7-H1801-00-00	. BRUSH SET	1	YPAD
6	JH7-H1872-10-00	. NUT, SPECIAL	4	YPAD
7	J51-H1843-00-00	. WASHER 1	2	YPAD
8	JH7-H1840-00-00	. BRUSH HOLDER ASSEMBLY	1	YPAD
9	JH7-H1848-00-00	. SCREW, BRUSH HOLDER ...	2	YPAD
10	JG6-H1824-00-00	. WASHER 2	2	YPAD
11	JH7-H1856-00-00	. BEARING	1	YPAD
12	J56-H1857-00-00	. RETAINER	1	YPAD
13	JH7-H1822-00-00	. BRACKET, STARTING MOTOR	1	YPAD
14	JG6-H1828-00-00	. BOLT 2	4	YPAD
15	JH7-H1846-00-00	. SCREW	2	YPAD
16	90101-06857-00	BOLT	3	YPAD
17	90215-06811-00	WASHER, LOCK	3	YPAD
18	90201-068E2-00	WASHER, PLATE	3	YPAD
19	JH7-H1829-00-00	GROMMET	1	YPAD

CONTROLLER 1

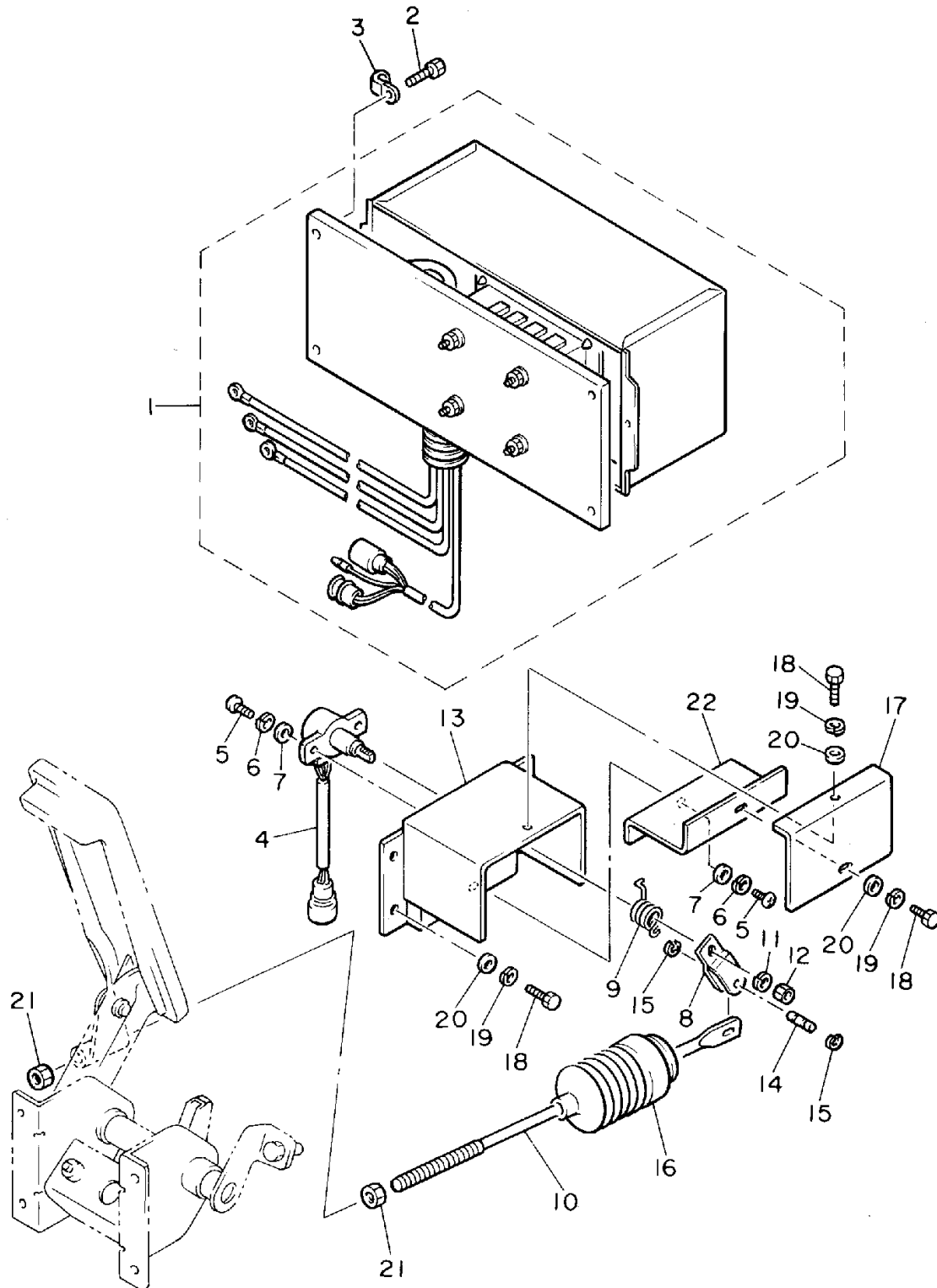

JH7100-3180

Ref. No.	Part Number	Description	Qty	Remarks
1	JF3-86510-11-00	MOTER CONTROL UNIT ASSEMBLY	1	
2	90105-06707-00	BOLT (95023-06016-00)	4	
3	90465-06038-00	CLAMP	1	
4	JF3-85885-02-00	THROTTLE SENSOR ASSEMBLY	1	
5	98580-05016-00	SCREW, PAN HEAD	3	
6	92990-05100-00	WASHER, SPRING	3	
7	92901-05600-00	WASHER, PLATE	3	
8	JF3-2625H-00-00	ARM, THROTTLE	1	
9	JF3-27825-00-00	SPRING, RETURN	1	
10	JF3-27241-00-00	ROD, JOINT	1	
11	92995-06100-00	WASHER, SPRING	1	
12	95601-06200-00	NUT, U FLANGE	1	
13	JF3-27981-00-00	BRACKET, THROTTLE	1	
14	JF3-27813-00-00	PIN, PEDAL CRANK	1	
15	99080-04600-00	CIRCLIP (E)	2	
16	JF3-27486-00-00	COVER 1	1	
17	JF3-27487-00-00	COVER 2	1	
18	97001-05016-00	BOLT (97002-05016-00)	6	
19	92990-05100-00	WASHER, SPRING	6	
20	92901-05600-00	WASHER, PLATE	6	
21	95303-08700-00	NUT	2	
22	JF3-27445-00-00	PLATE 1	1	

CONTROLLER 2

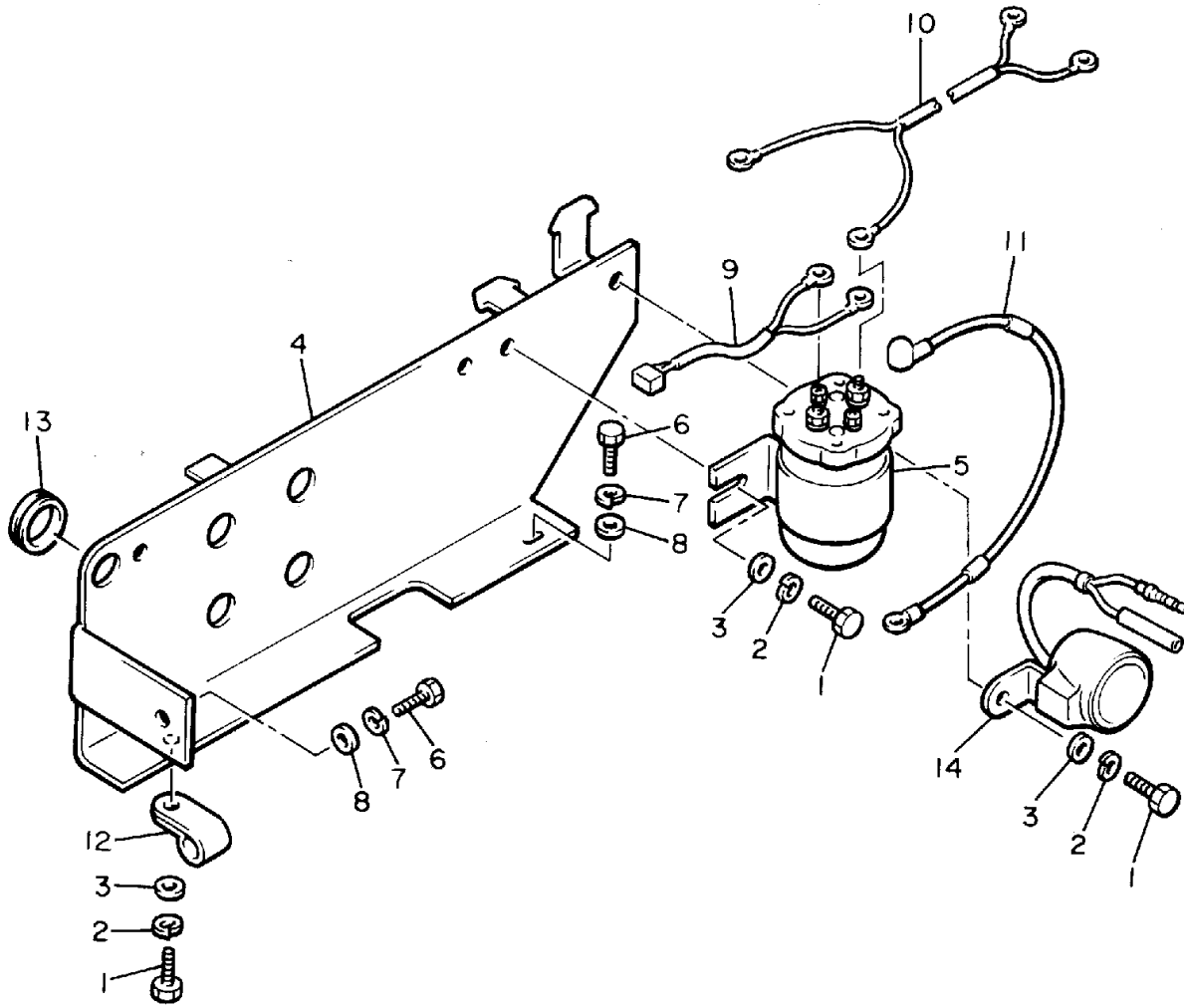

Ref. No.	Part Number	Description	Qty	Remarks
1	97011-06016-00	BOLT	3	
2	92995-06100-00	WASHER, SPRING	3	
3	92990-06600-00	WASHER, PLATE	3	
4	JH7-H6141-01-00	PLATE, CONTROLLER	1	YPAD
5	JF3-H1950-00-00	RELAY ASSEMBLY	1	YPAD
6	97011-08016-00	BOLT	2	
7	92902-08100-00	WASHER, SPRING	2	
8	92990-08600-00	WASHER, PLATE	2	
9	JF2-82105-00-00	WIRE HARNESS	1	
10	J41-82542-00-00	WIRE, LEAD	1	
11	JH7-H2115-00-00	WIRE, PLUS LEAD	1	YPAD
12	90465-08M08-00	CLAMP	2	
13	90480-21425-00	GROMMET	1	
14	JF3-83383-02-00	BUZZER	1	



JH7100-3190

ELECTRICAL 1

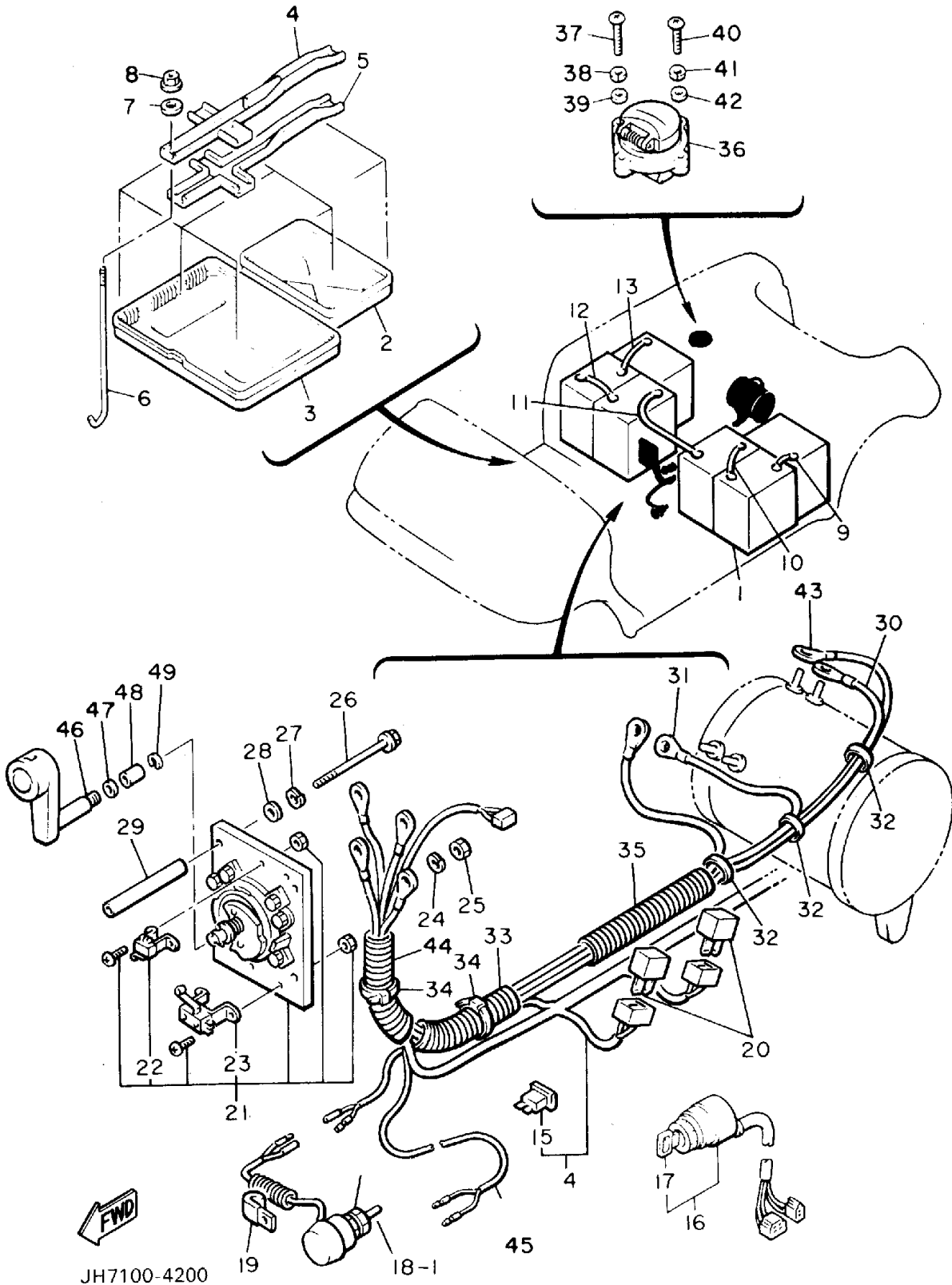

Ref. No.	Part Number	Description	Qty	Remarks
1	UNA-VAILA-BL-EI	0 0		
2	J56-H2122-00-00	SEAT, BATTERY	2	YPAD
3	J56-H2123-00-00	SEAT, BATTERY	2	YPAD
4	J41-82136-01-00	PLATE, BATTERY FITTING ...	2	
5	J41-82121-00-00	PAD, BATTERY	2	
6	J14-82133-01-00	SCREW, FITTING	4	
7	90201-06067-00	WASHER, PLATE	4	
8	95701-06500-00	NUT, FLANGE	4	
9	J56-H2127-00-00	WIRE, LEAD 2	1	YPAD
10	J56-H2117-00-00	WIRE, LEAD	1	YPAD
11	J56-H2149-00-00	WIRE, LEAD 3	1	YPAD
12	J56-H2127-00-00	WIRE, LEAD 2	1	YPAD
13	J56-H2117-00-00	WIRE, LEAD	1	YPAD
14	JH7-82590-01-00	WIRE HARNESS ASSEMBLY ..	1	
15	42X-82151-00-00	. FUSE (10A-BL)	2	
16	J55-82510-00-00	MAIN SWITCH ASSEMBLY ...	1	
17	J17-82511-20-00	. KEY, MAIN SWITCH	1	
18	J41-82550-02-00	STOP SWITCH ASSEMBLY ...	1	
19	90465-06038-00	CLAMP	1	
20	J44-81980-60-00	DIODE	2	
21	JF3-82917-01-00	SWITCH	1	
22	J41-82617-00-00	. SWITCH	1	
23	J41-82817-00-00	. MICRO SWITCH	1	
24	92995-06100-00	WASHER, SPRING	4	
25	95601-06200-00	NUT, U FLANGE	4	
26	97021-06080-00	BOLT (97001-06080-00)	4	
27	92995-06100-00	WASHER, SPRING	4	
28	92990-06600-00	WASHER, PLATE	4	
29	90387-061M8-00	COLLAR	4	

CONTINUED ON NEXT FRAME ►

ELECTRICAL 1

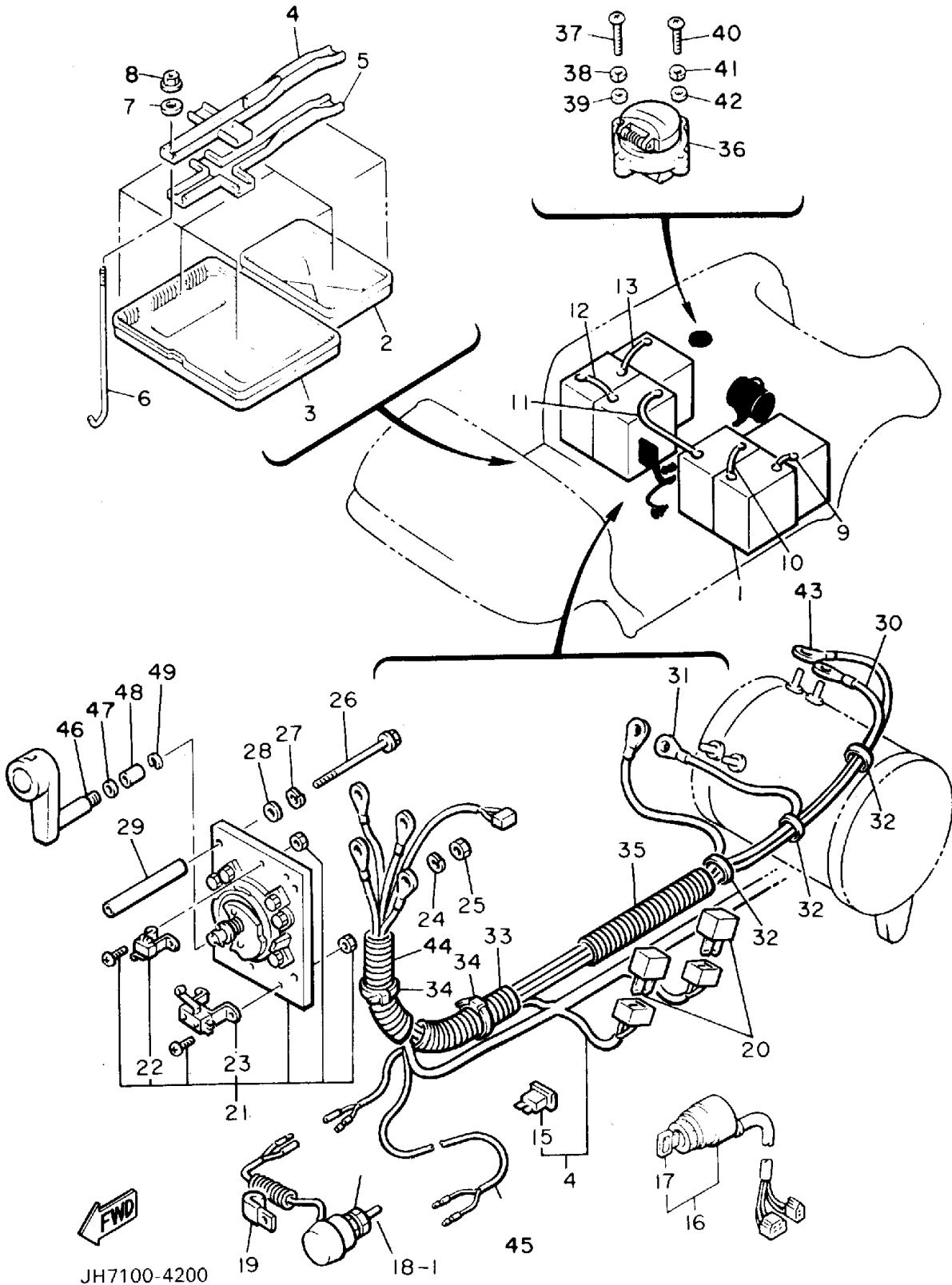

Ref. No.	Part Number	Description	Qty	Remarks
30	JH7-H2521-00-00	WIRE, LEAD	1	YPAD
31	JH7-H2531-00-00	WIRE, LEAD	1	YPAD
32	90601-200U1-00	BAND	3	
33	J56-H7197-00-00	TUBE 2	1	YPAD
34	12R-82591-00-00	BAND	2	
35	J56-H7196-00-00	TUBE 1	1	YPAD
36	JF3-86181-00-00	RECEPTACLE	1	
37	98506-05035-00	SCREW, PAN HEAD	2	
38	92906-05100-00	WASHER, SPRING	2	
39	92906-05600-00	WASHER, PLATE	2	
40	98586-05016-00	SCREW, PAN HEAD	2	
41	92906-05100-00	WASHER, SPRING	2	
42	92906-05600-00	WASHER, PLATE	2	
43	JH7-H6171-00-00	WIRE, LEAD 1	1	YPAD
44	JH7-H7197-00-00	TUBE 2	1	YPAD
45	JH7-H6527-00-00	WIRE 7	1	YPAD
46	J41-46381-00-00	KNOB, SHIFT	1	
47	90201-12474-00	WASHER, PLATE	1	
48	J41-46394-00-00	JOINT	1	
49	99001-08600-00	CIRCLIP	1	
	G9E-PARTS-BO-AR	ASSEMBLY, HARDWARE	9	OPTIONAL PART
18-1	JF2-82532-00-00	. CAP, RUBBER	1	

ALTERNATE (DRAW-BAR)

Ref. No.	Part Number	Description	Qty	Remarks
1	ABA-JG599-20-00	PIVOT ARM ASSEMBLY	1	YPAD
2	ABA-JG599-10-00	DRAW BAR ASSEMBLY	1	YPAD
3	ABA-JF286-00-00	REAR HITCH	1	YPAD

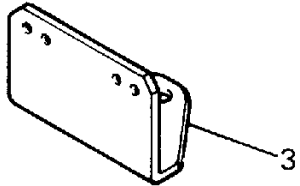
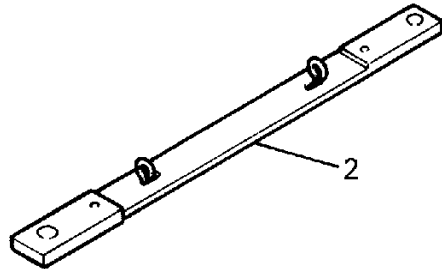
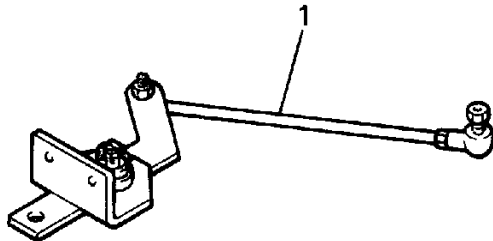

JH7100-4210

GOLF CAR	DATE: 05/25/94	BUL: G94-002
----------	----------------	--------------

G9AK/EK

TOE-IN SETTING CHANGES

INTRODUCTION

A revised toe-in specification is used on affected 1994 cars. These cars are equipped with a different shock absorber.

DEALER ACTION SUMMARY

Add the revised toe-in specification and affected unit range to all service literature

and service manuals that include these models.

SERVICE INFORMATION

The revised toe-in specification is as follows:
UNLOADED CONDITION

G9AK **9.5mm ± 5mm**

G9EK **7.0mm ± 5mm**

Unloaded condition is a fully assembled gas car with a full tank of fuel, or a fully assembled electric with all batteries installed, but without accessories, operator, passenger or golf bags.

It is normally not necessary to check or set toe-in on new cars at predelivery.

If an adjustment is necessary, follow the procedure outlined in Technical Bulletin G91-002A. However, use the tire pressure specifications for the 1994 cars of 16~20 psi.

AFFECTED UNITS

G9AK/AK1 JG5-307130 ~

G9EK/EK1/EKP JH7-201368 ~

WARRANTY INFORMATION

No warranty applies with this bulletin. This is for information purposes only.

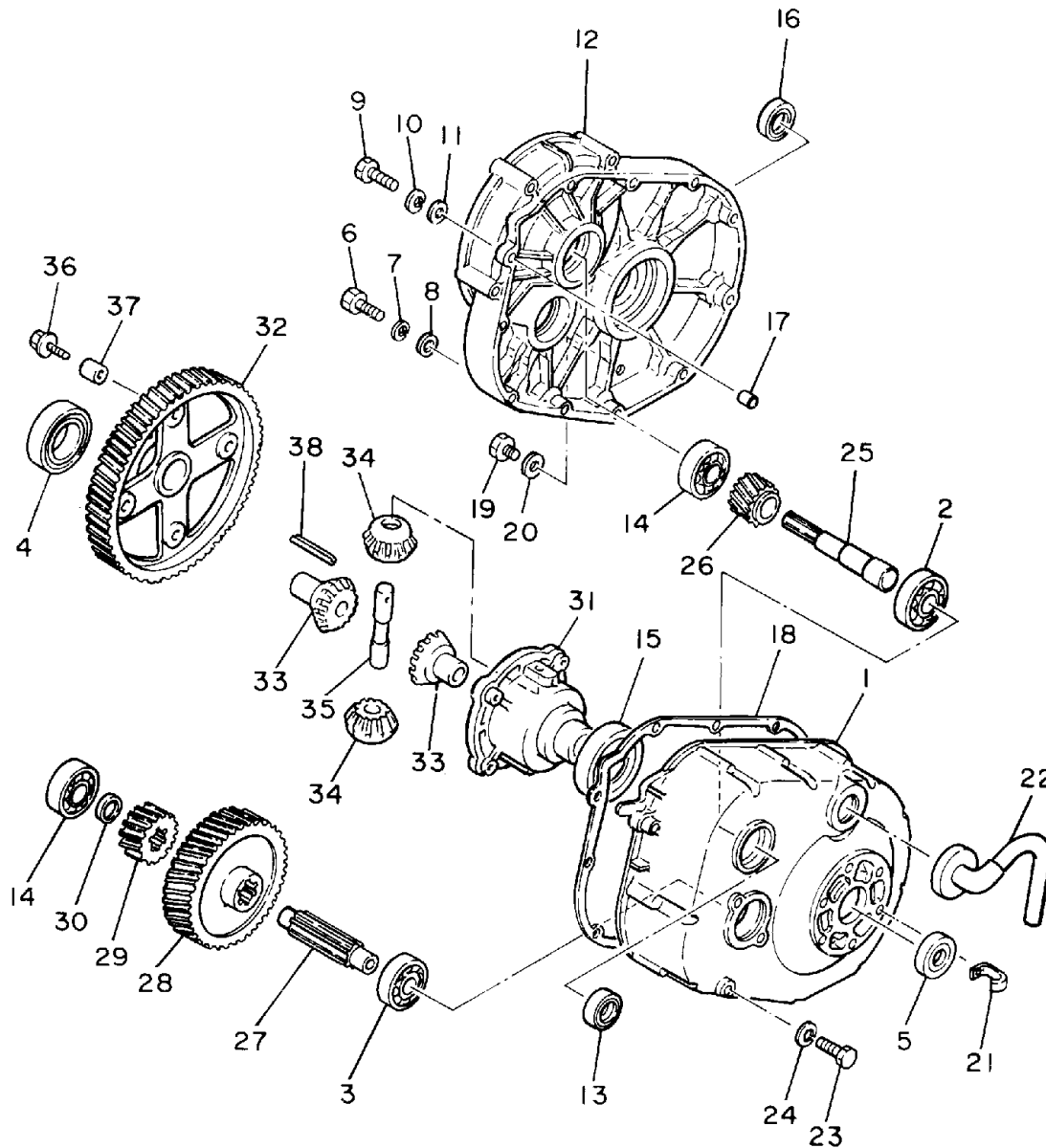

JH7100-3090

PAGE 1 OF 1

© 1994 YAMAHA MOTOR MANUFACTURING CORPORATION of AMERICA