



YAMAHA

GENUINE

PARTS CATALOGUE

GOLF CAR

CYLINDER

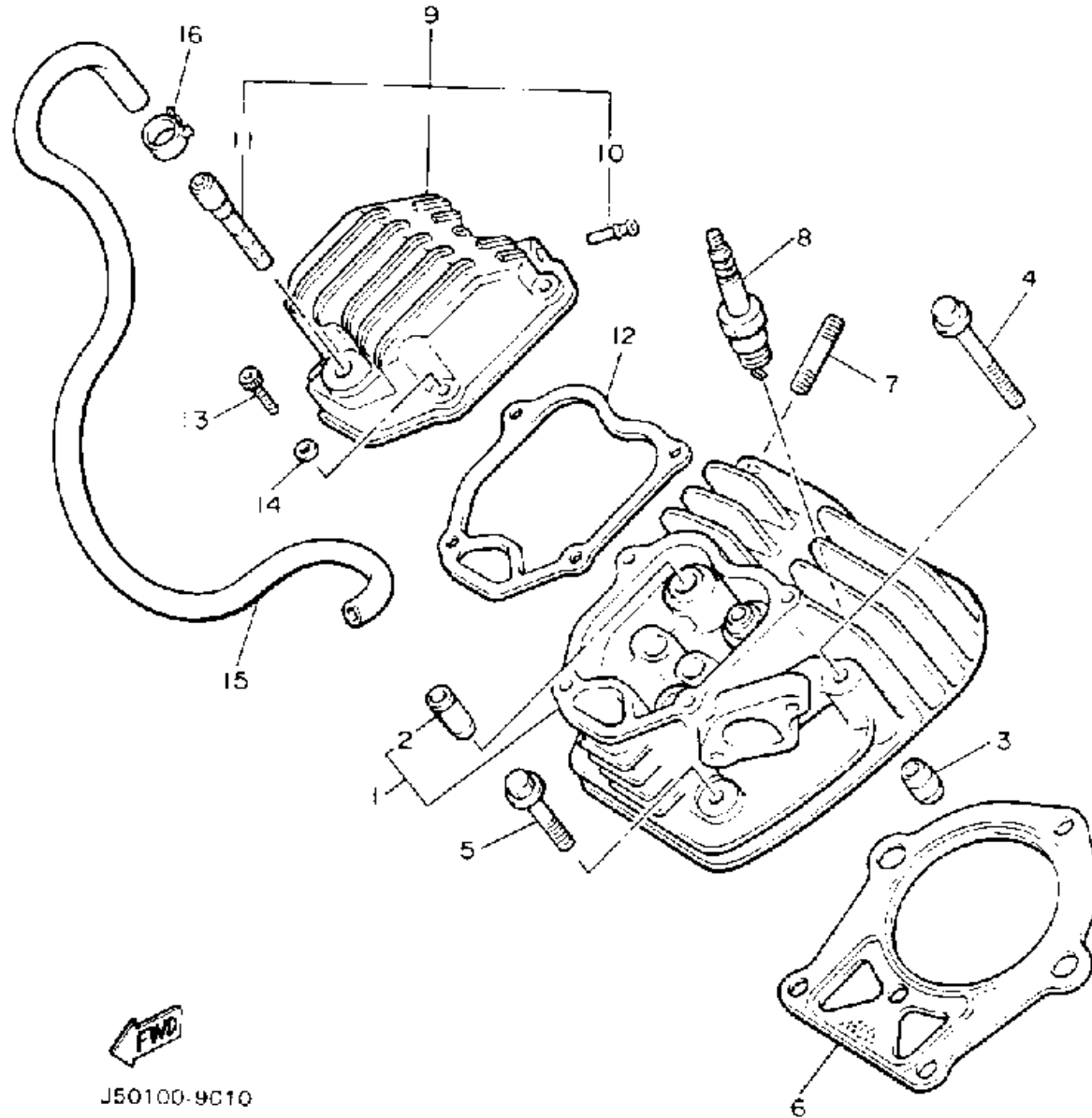

Ref. No.	Part Number	Description	Qty	Remarks
1	J38-11102-00-00	CYLINDER HEAD ASSEMBLY	1	
2	J38-11133-09-00	. GUIDE, INTAKE VALVE	2	
3	99510-12016-00	PIN, DOWEL	2	
4	95811-08070-00	BOLT, FLANGE	3	
5	95811-08045-00	BOLT, FLANGE (JN5)	3	
6	J38-11181-00-00	GASKET, CYLINDER HEAD 1	1	
7	95612-08618-00	BOLT, STUD	2	
8	NGK-BR4ES-00-00	PLUG, SPARK (NGK BR4ES)	1	
9	J38-11191-00-00	COVER, CYLINDER HEAD 1	1	
10	J38-11116-00-00	. JOINT, BREATHER	2	
11	J38-24461-00-00	. PIPE, JOINT	1	
12	J38-11193-01-00	GASKET, HEAD COVER 1	1	
13	91316-06025-00	BOLT	4	
14	92990-06600-00	WASHER, PLATE	4	
15	90445-130F8-00	HOSE	1	
16	90467-12052-00	CLIP	2	

J50100-9C10

CRANKSHAFT-PISTON

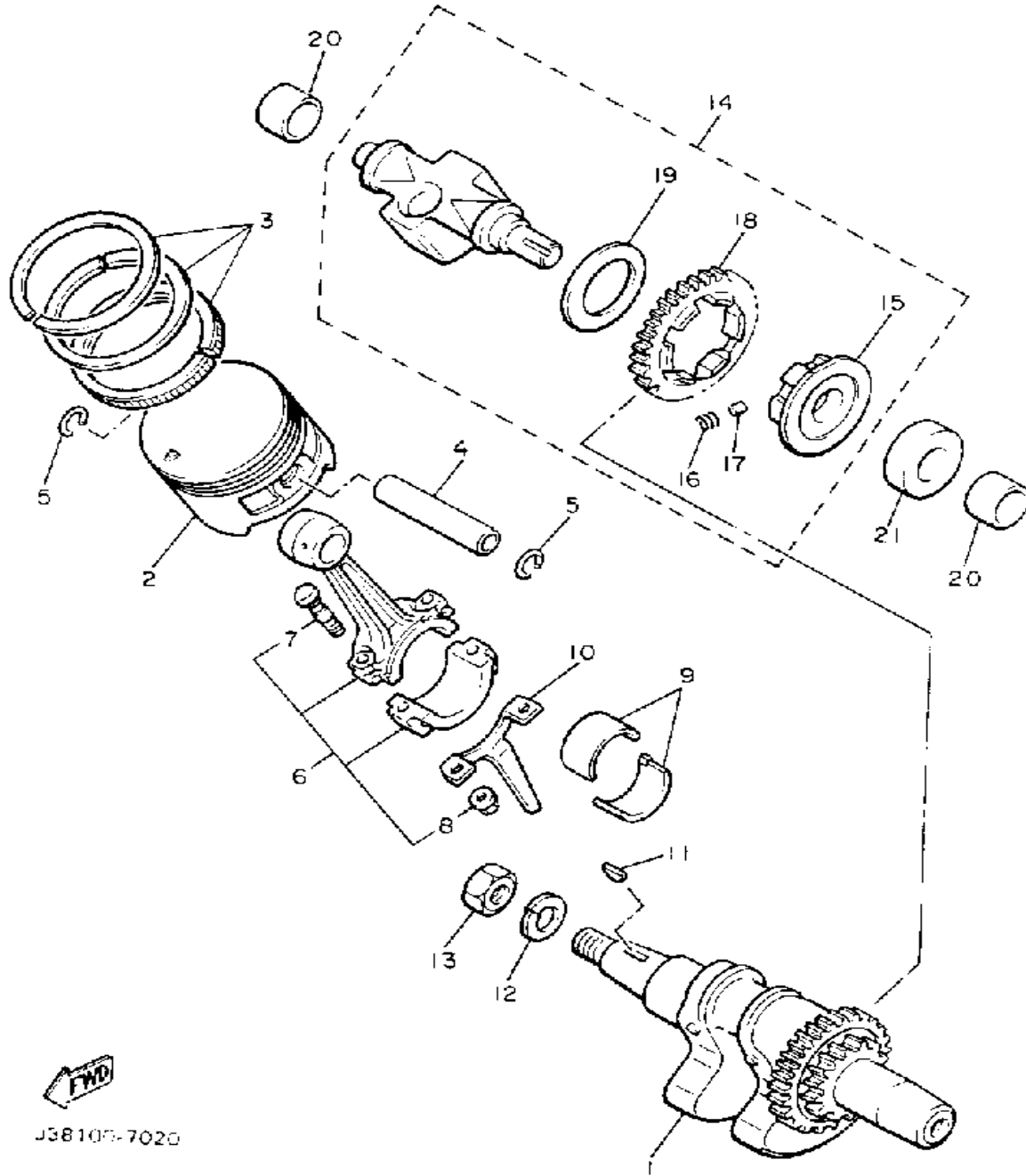

Ref. No.	Part Number	Description	Qty	Remarks
1	J38-11400-00-00	CRANKSHAFT ASSEMBLY ...	1	
2	J38-11631-01-A0	PISTON (STD)	1	
	J38-11635-01-00	PISTON (0.25MM O/S)	1	AP
	J38-11636-01-00	PISTON (0.50MM O/S)	1	AP
3	J38-11610-00-00	PISTON RING SET (STD)	1	
	J38-11610-10-00	PISTON RING SET (0.25MM O/S)	1	AP
	J38-11610-20-00	PISTON RING SET (0.50MM O/S)	1	AP
4	7A9-11633-00-00	PIN, PISTON	1	
5	93450-19047-00	CIRCLIP	2	
6	J38-11650-00-00	CONNECTING ROD ASSEMBLY	1	
7	J38-11654-00-00	. BOLT, CONNECTING ROD	2	
8	90179-08327-00	. NUT	2	
9	J38-11656-00-00	BEARING, CON-ROD	2	UR BROWN
	J38-11656-10-00	BEARING, CON-ROD	2	UR BLACK
	J38-11656-20-00	BEARING, CON-ROD	2	UR BLUE
10	J38-11657-00-00	SPLASHER, OIL	1	
11	90280-16053-00	KEY, WOODRUFF	1	
12	92901-16100-00	WASHER, SPRING	1	
13	90170-16182-00	NUT	1	
14	J38-11500-00-00	BALANCER ASSEMBLY	1	
15	J38-11496-00-00	. BOSS, BUFFER	1	
16	90501-21133-00	. SPRING, COMPRESSION	6	
17	93605-10090-00	. PIN, DOWEL	3	
18	J38-11531-00-00	. GEAR, BALANCE WT	1	
19	90201-201G9-00	. WASHER, PLATE	1	
20	90387-155R3-00	COLLAR	2	
21	90387-152M7-00	COLLAR	1	

AIR SHROUD-FAN

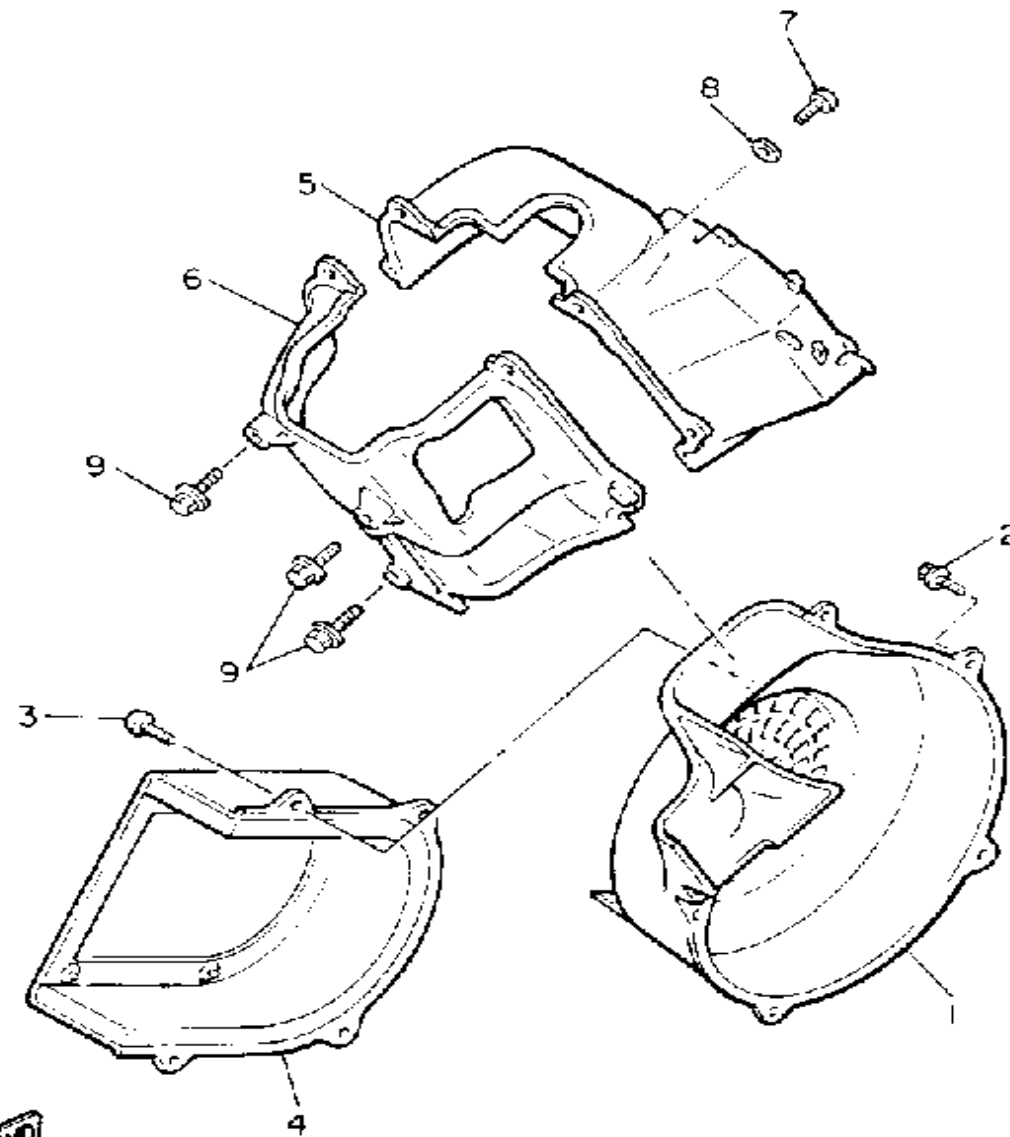

J50100-8040

Ref. No.	Part Number	Description	Qty	Remarks
1	J38-12621-01-00	CASE, FAN	1	
2	95811-06020-00	BOLT, FLANGE	5	
3	97780-60116-00	SCREW, TAPPING	4	
4	J38-12640-00-00	FAN CASE COVER COMP. ...	1	
5	J38-12651-01-00	AIR SHROUD, CYLINDER 1 ...	1	
6	J38-12652-00-00	AIR SHROUD, CYLINDER 2 ...	1	
7	98502-06016-00	SCREW, PAN HEAD (98501-06014-00)	4	
8	92990-06600-00	WASHER, PLATE	4	
9	90109-06513-00	BOLT	4	

AIR FILTER

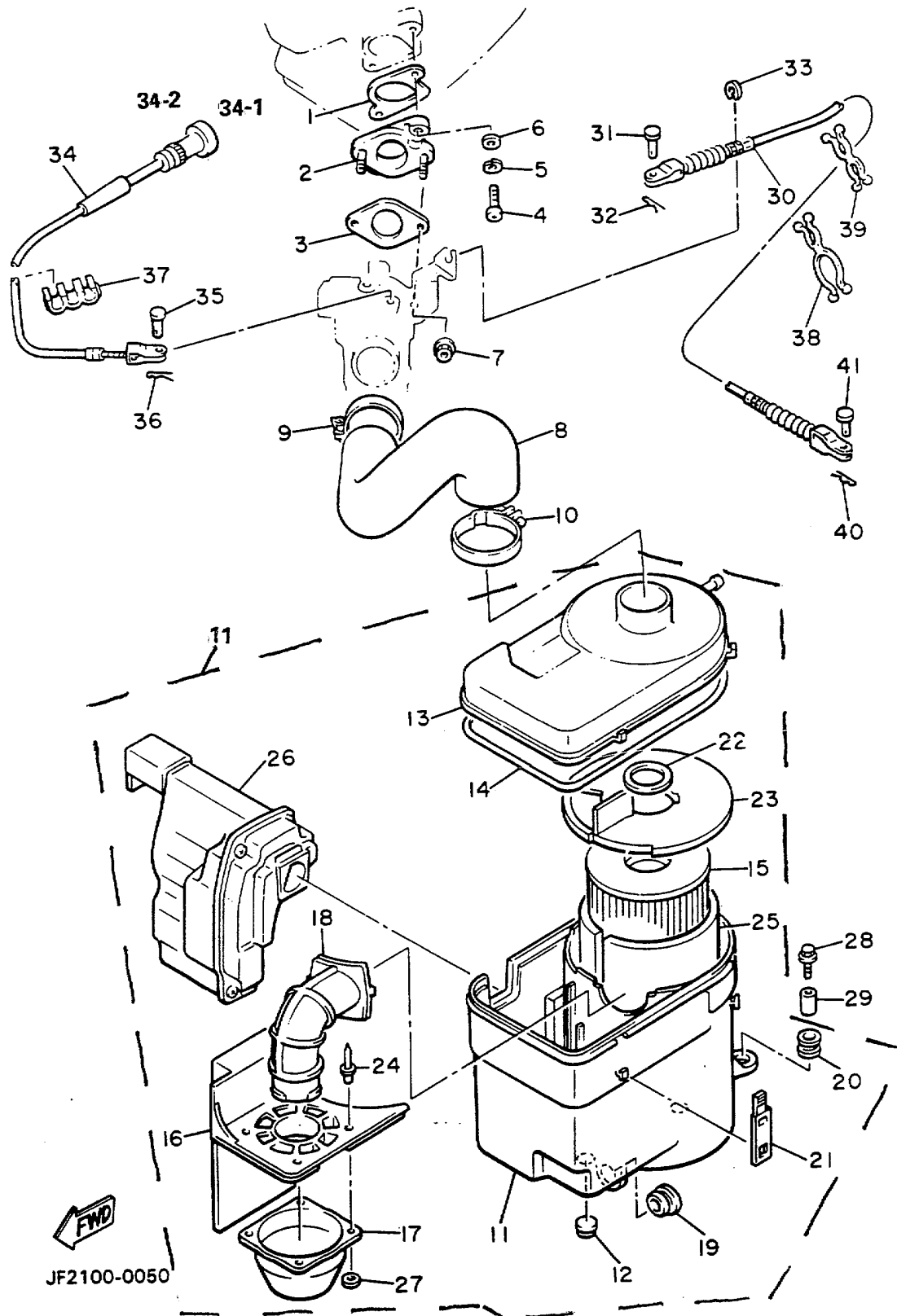

Ref. No.	Part Number	Description	Qty	Remarks
1	J38-13556-00-00	GASKET, MANIFOLD	1	
2	J38-13596-00-00	JOINT, CARBURETOR 2	1	
3	J38-13557-00-00	GASKET	1	
4	98501-06030-00	SCREW, PAN HEAD (92501-06030-00)	2	
5	92990-06100-00	WASHER, SPRING	2	
6	92990-06600-00	WASHER, PLATE	2	
7	95601-06200-00	NUT, U FLANGE	2	
8	J38-14453-01-00	JOINT, AIR CLEANER 1	1	
9	90460-43279-00	CLAMP, HOSE	1	
10	90460-53239-00	CLAMP, HOSE	1	
11	J38-14410-00-00	AIR CLEANER ASSEMBLY ...	1	
12	90480-14100-00	. GROMMET	2	
13	J38-14412-02-00	. CAP, CLEANER CASE 1	1	
14	J38-14452-00-00	. SEAL	1	
15	J38-14450-00-00	. ELEMENT ASSEMBLY, AIR CLEANER	1	
16	J38-14484-00-00	. PLATE, CLEANER CASE FITTING	1	
17	J38-14479-00-00	. FUNNEL	1	
18	J38-14419-00-00	. PIPE	1	
19	90480-18277-00	. GROMMET	1	
20	90480-13238-00	. GROMMET	2	
21	J10-14436-00-00	. HOOK	4	
22	J38-14416-00-00	. GASKET, AIR CLEANER	1	
23	J38-1441F-00-00	. PARTN, AIR CLNR CSAIR CLEANER CASE	1	
24	90267-40073-00	. RIVET, BLIND	4	
25	J10-14417-00-00	. COVER 1	1	
26	J38-1446A-00-00	. SURGE TANK ASSEMBLY ...	1	

CONTINUED ON NEXT FRAME ►

AIR FILTER

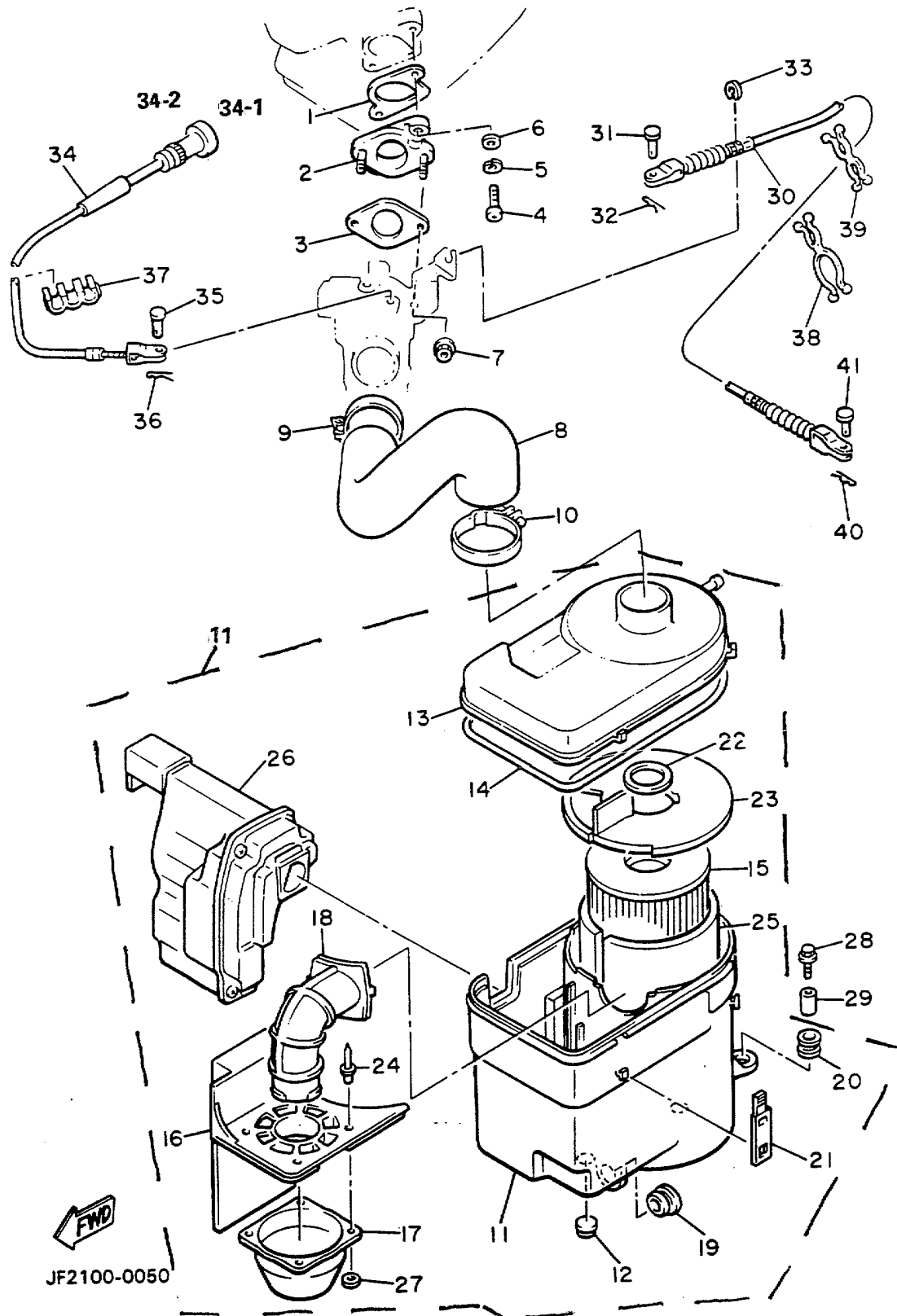

Ref. No.	Part Number	Description	Qty	Remarks
27	90201-114E6-00	. WASHER, PLATE	4	
28	90119-06097-00	BOLT, WITH WASHER	2	
29	90387-07390-00	COLLAR	2	
30	J38-26312-00-00	CABLE, THROTTLE 2	1	
31	91701-05010-00	PIN, CYLINDER. HEAD	1	
32	90468-10050-00	CLIP	1	
33	99080-07600-00	CIRCLIP (E)	1	
34	JF2-F6331-00-00	CABLE, STARTER 1	1	
35	91701-05010-00	PIN, CYLINDER. HEAD	1	
36	90468-10050-00	CLIP	1	
37	90468-07179-00	CLIP	1	
38	90464-26114-00	CLAMP	1	
39	90464-16115-00	CLAMP	2	
40	90468-10050-00	CLIP	1	
41	91701-05010-00	PIN, CYLINDER. HEAD	1	
11-1	J38-14411-00-00	. CASE, AIR CLEANER 1	1	
34-1	1AE-26325-00-00	. KNOB, CHOKE	1	
34-2	90149-03132-00	. SCREW, SPECIAL SHAPE ...	1	

CARBURETOR

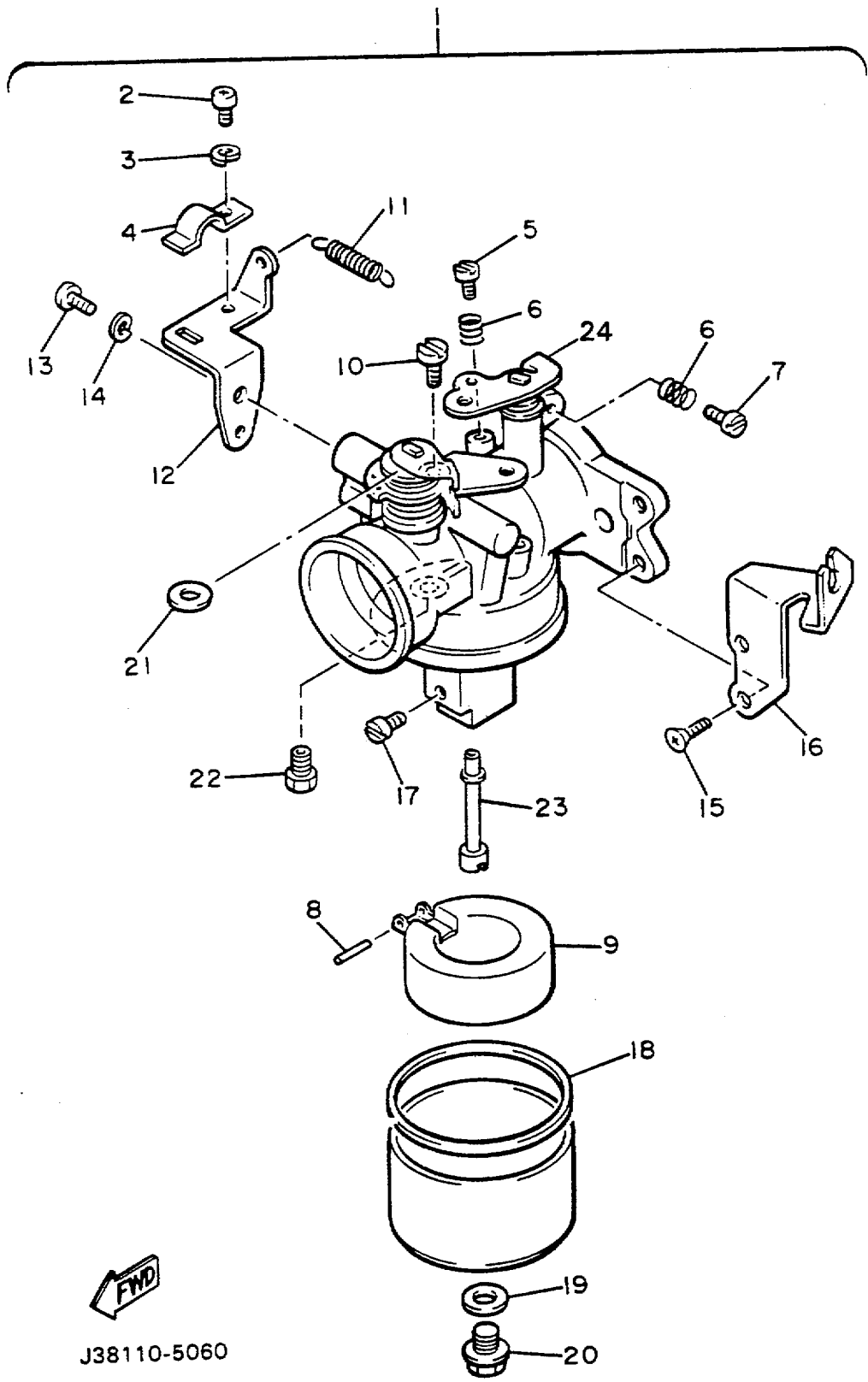

Ref. No.	Part Number	Description	Qty	Remarks
1	J38-14101-01-00	CARBURETOR ASSEMBLY 1	1	
2	98580-05010-00	. SCREW, PAN HEAD	1	
3	92990-05100-00	. WASHER, SPRING	1	
4	J38-14243-00-00	. PLATE	1	
5	75G-14211-00-00	. SCREW, PILOT ADJUSTING	1	
6	620-14212-00-00	. SPRING, PILOT ADJUSTING	2	
7	J10-14122-00-00	. SCREW, THROTTLE	1	
8	J38-14186-00-00	. PIN, FLOAT	1	
9	J38-14185-00-00	. FLOAT	1	
10	620-14142-67-00	. JET, PILOT (#67.5)	1	AP
	620-14142-72-00	. JET, PILOT (#72.5)	1	UR STD
11	J38-14133-00-00	. SPRING, THROTTLE STOP	1	
12	J38-14581-00-00	. BRACKET	1	
13	98580-06010-00	. SCREW, PAN HEAD (92503-06010)	1	
14	92990-06100-00	. WASHER, SPRING	1	
15	98701-05008-00	. SCREW, FLAT HEAD	2	
16	J38-14291-00-00	. BRACKET 1	1	
17	3G2-1423E-41-00	. JET, MAIN (#103.8)	1	AP FOR HIGH LANDS
	3G2-1423E-42-00	. JET, MAIN (#106.3)	1	UR STD
18	796-14184-00-00	. GASKET, FLOAT CHAMBER	1	
19	127-14198-00-00	. GASKET	1	
20	7R1-14162-00-00	. BOLT, HOLDING	1	
21	J10-14597-00-00	. WASHER	1	
22	J38-14150-00-00	. NEEDLE ASSEMBLY	1	
23	J38-14141-00-00	. NOZZLE, MAIN	1	
24	J10-14131-00-00	SPRING, THROTTLE	1	OPTIONAL PART
	J38-14202-09-00	. THROTTLE LEVER COMP	1	
34-2	J10-14535-00-00	. BUSHING, THROTTLE SHAFT	1	OPTIONAL PART

CONTINUED ON NEXT FRAME ►

CARBURETOR

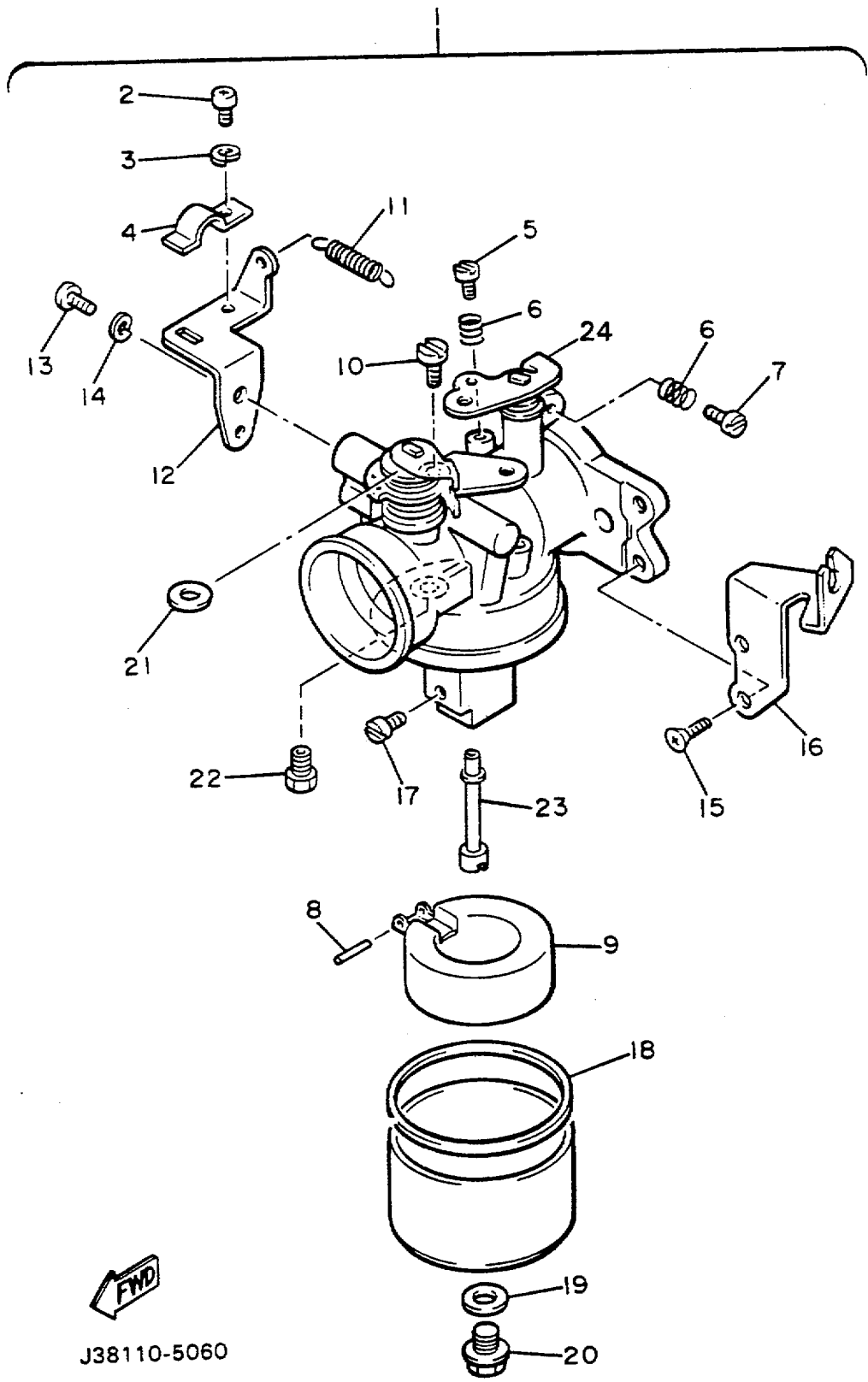

Ref. No.	Part Number	Description	Qty	Remarks
34-2	J10-14582-00-00	. ARM, CHOKE	1	OPTIONAL PART
	J38-14218-00-00	. SPRING, LOWER CHOKE ...	1	OPTIONAL PART
	J38-14589-00-00	. SPRING, UPPER CHOKE	1	OPTIONAL PART

EXHAUST

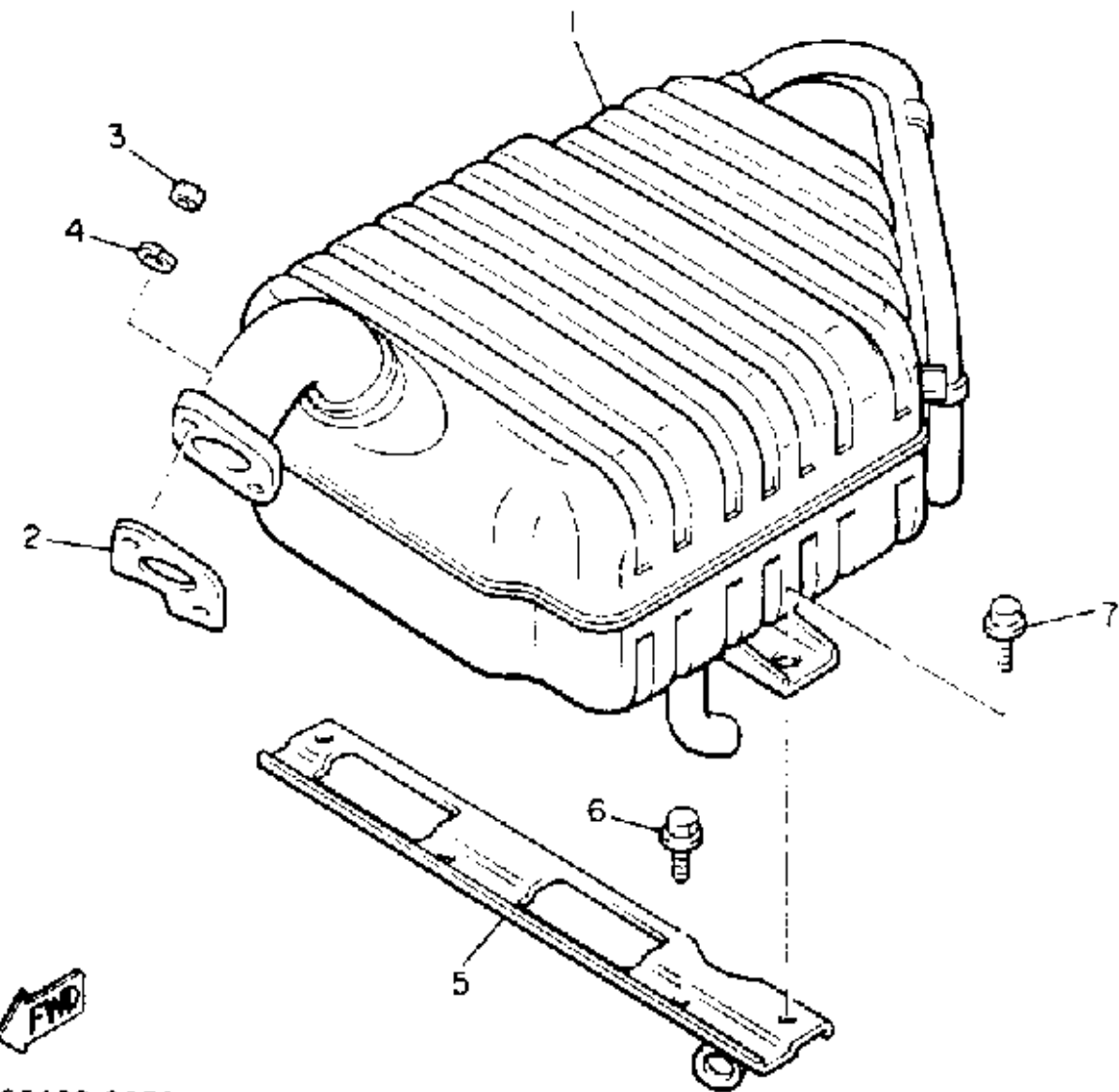

J55100-9070

Ref. No.	Part Number	Description	Qty	Remarks
1	J55-E4710-01-00	MUFFLER ASSEMBLY 1	1	J38-14710-01
2	J38-14613-01-00	GASKET, EXHAUST PIPE	1	
3	95380-08600-00	NUT	2	
4	92990-08100-00	WASHER	2	
5	J38-14771-00-00	STAY, MUFFLER 1	1	
6	95026-10020-00	BOLT, FLANGE	2	
7	90119-08119-00	BOLT, WITH WASHER	2	

CRANKCASE

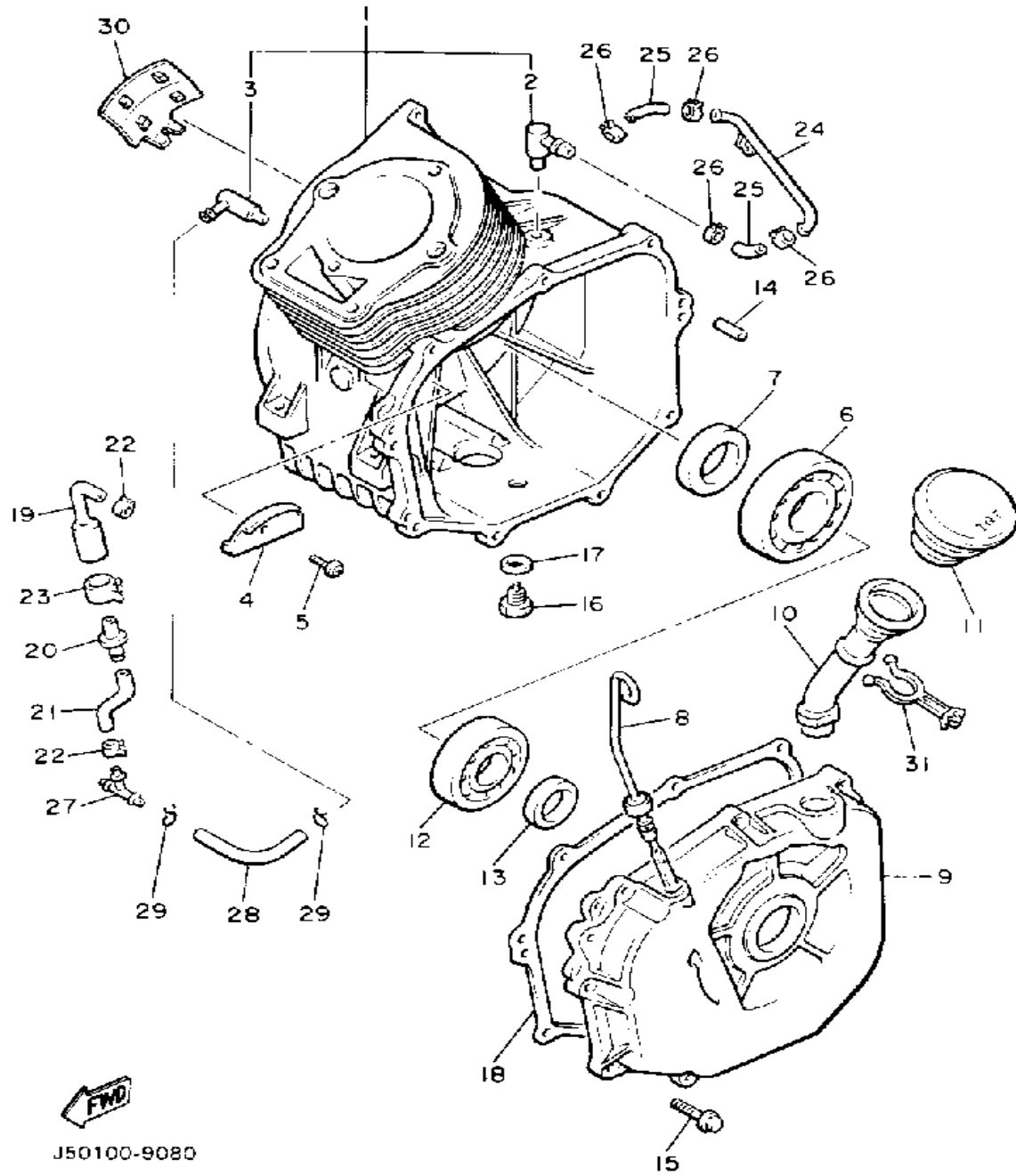

Ref. No.	Part Number	Description	Qty	Remarks
1	J38-15100-02-00	CRANKCASE ASSEMBLY	1	
2	J38-15148-00-00	. NOZZLE 2	1	
3	J38-15155-00-00	. NOZZLE 3	1	
4	J38-15123-00-00	PLATE, BUFFLE 1	1	
5	90159-05117-00	SCREW, w/washer	1	
6	93306-30709-00	BEARING	1	
7	93102-35191-00	OIL SEAL	1	
8	J38-15361-00-00	GAUGE, LEVEL	1	
9	J38-15411-01-00	COVER, CRANKCASE 1	1	
10	J38-15112-00-00	PIPE, OIL	1	
11	J38-15363-00-00	PLUG, OIL	1	
12	93306-30630-00	BEARING	1	
13	93102-30195-00	OIL SEAL	1	
14	93608-12063-00	PIN, DOWEL	2	
15	95811-08035-00	BOLT, FLANGE (95821-08035)	9	
16	97001-12020-00	BOLT	1	
17	812-11198-00-00	GASKET	1	
18	J38-15451-00-00	GASKET, CRCS COVERCRANKCASE COVER 1	1	
19	J38-14388-00-00	VALVE, VACUUM CONTROL	1	
20	J38-13115-00-00	CONNECTOR, SUCTION PIPE	1	
21	90445-113E4-00	HOSE	1	
22	90467-10008-00	CLIP	2	
23	90468-08104-00	CLIP	1	
24	J38-13161-00-00	PIPE, DELIVERY 1	1	
25	90445-110E6-00	HOSE	2	
26	90467-10008-00	CLIP	4	
27	807-24376-00-00	PIPE, JOINT 1	1	
28	90445-09073-00	HOSE	1	

CONTINUED ON NEXT FRAME ►

CRANKCASE

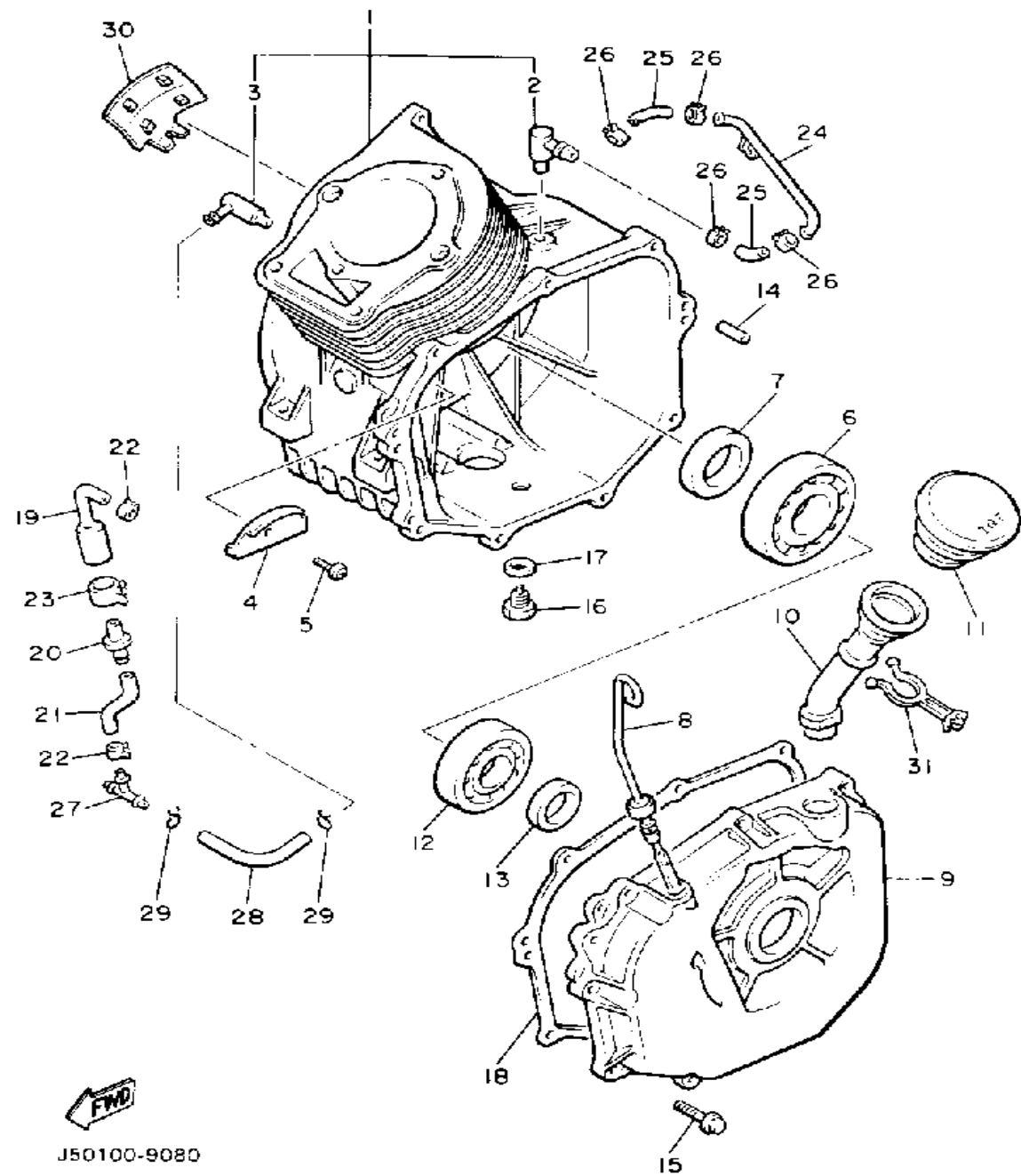

Ref. No.	Part Number	Description	Qty	Remarks
29	90467-08017-00	CLIP	2	
30	J38-11355-00-00	SEAL, CYLINDER 1	1	
31	90464-15093-00	CLAMP	1	

J50100-9080

ENGINE BRACKET

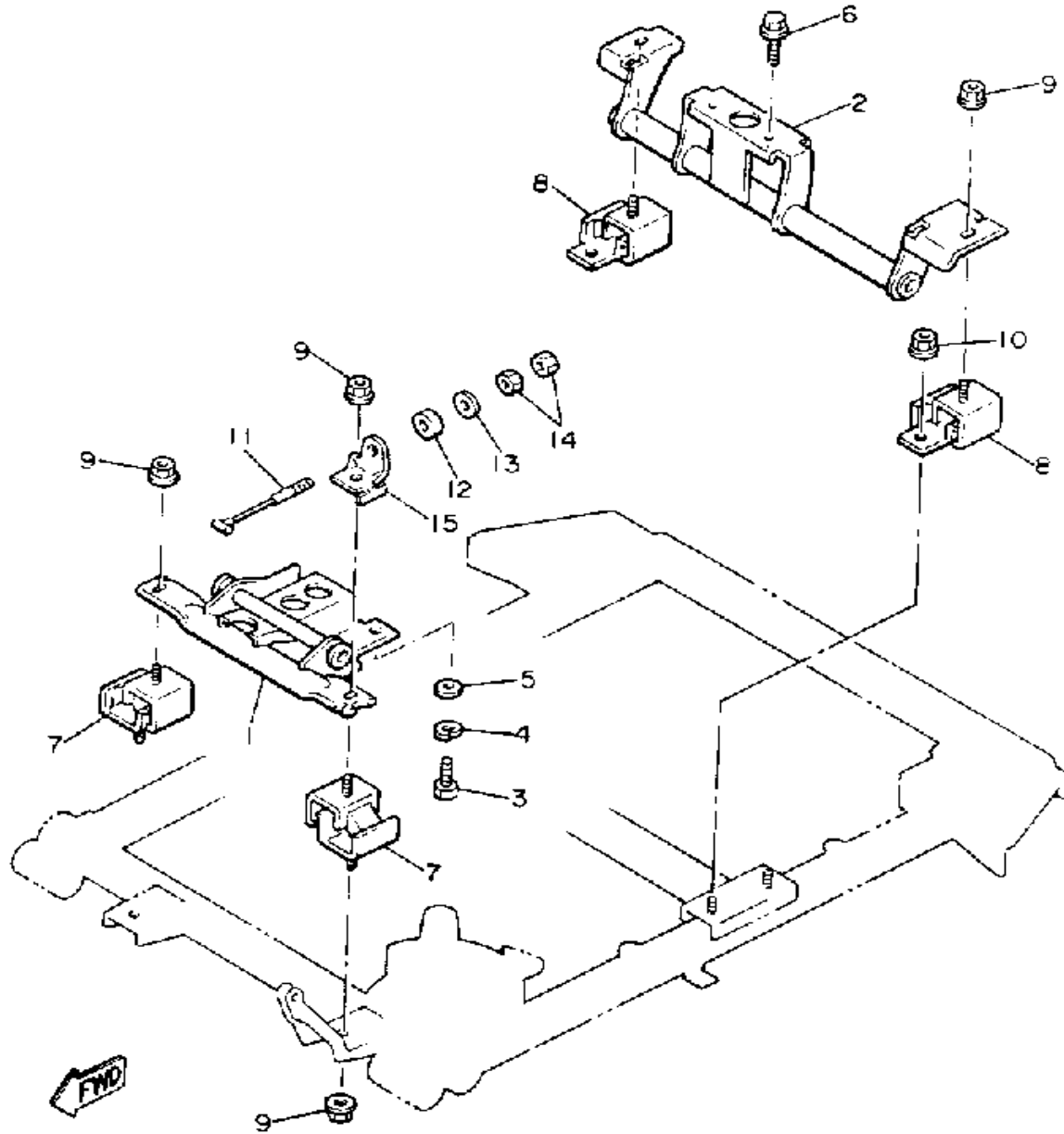

J38100-7090

Ref. No.	Part Number	Description	Qty	Remarks
1	J38-21411-02-00	BRACKET, ENGINE 1	1	
2	J55-F1419-00-00	BRACKET, ENGINE 2	1	J38-21419-02
3	97011-10025-00	BOLT	2	
4	92901-10100-00	WASHER, SPRING	2	
5	92990-10600-00	WASHER, PLATE	2	
6	95021-10040-00	BOLT, FLANGE	2	
7	J38-21486-00-00	DAMPER 2	2	
8	J38-21488-00-00	DAMPER	2	
9	95701-10500-00	NUT, FLANGE (95702-10500)	6	
10	95701-08500-00	NUT, FLANGE	4	
11	J31-2217J-01-00	TENSIONER 1	1	
12	J17-2214F-00-00	DAMPER 1	1	
13	90201-06778-00	WASHER, PLATE	1	
14	95380-06600-00	NUT	2	
15	J38-2141A-00-00	BRACKET 1	1	

REAR SHOCKS-SUSPENSION

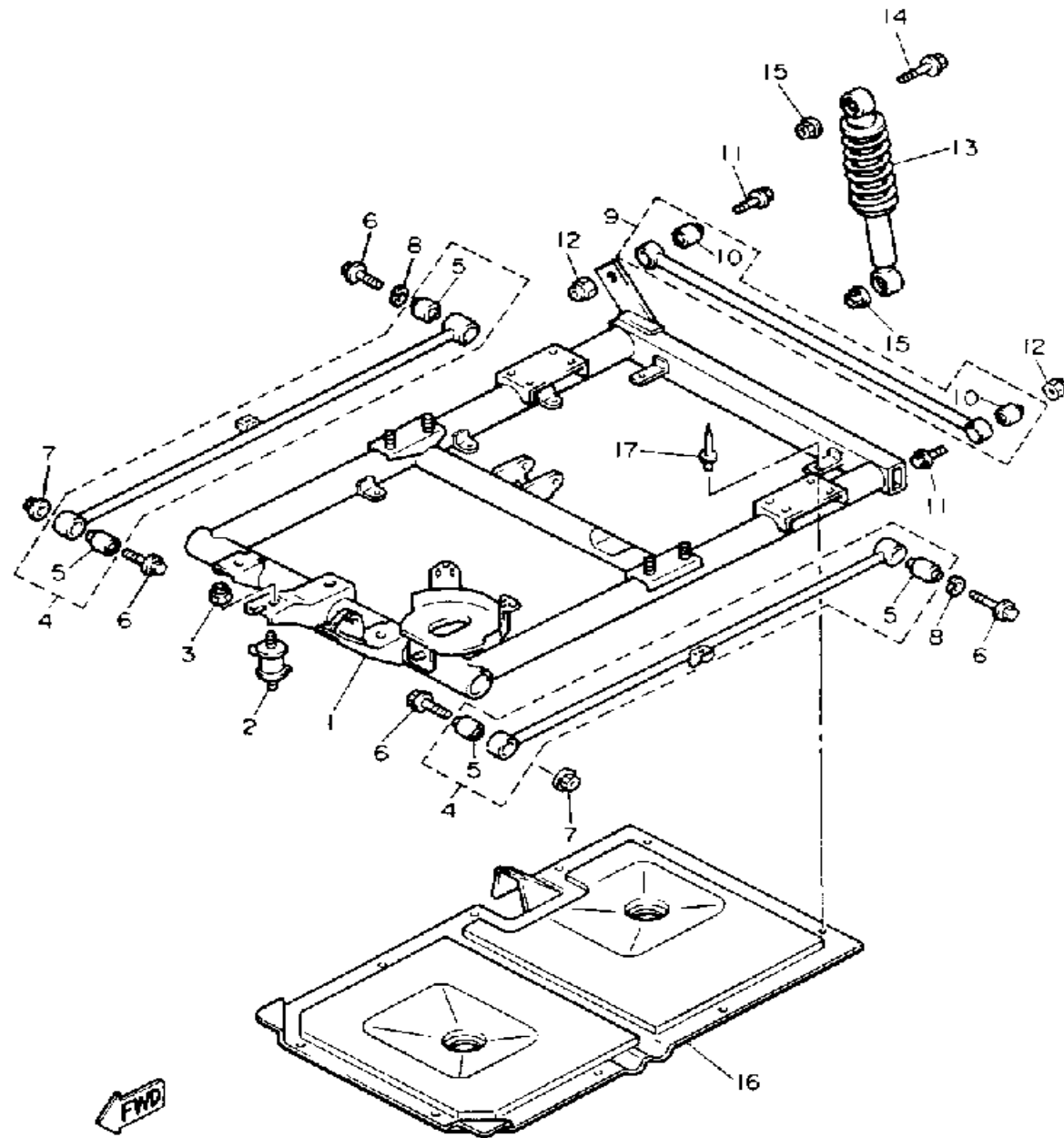

Ref. No.	Part Number	Description	Qty	Remarks
1	JF2-F2110-00-00	REAR ARM COMP.	1	
2	J50-22123-00-00	BUSH 1	1	
3	90185-10115-00	NUT, SELF-LOCKING	2	
4	J50-22171-00-00	ARM, REAR 1	2	
5	J50-22124-00-00	. BUSH 2	2	
6	95812-12065-00	BOLT, FLANGE	4	
7	90185-12072-00	NUT, SELF-LOCKING	2	
8	92901-12100-00	WASHER, SPRING	2	
9	JF2-22172-00-00	ARM, REAR 2	1	
10	J50-22124-00-00	. BUSH 2	2	
11	95812-12065-00	BOLT, FLANGE	2	
12	90185-12072-00	NUT, SELF-LOCKING	2	
13	JF2-22210-01-00	SHOCK ABSORBER ASSEMBLY, REAR	2	
14	95812-12065-00	BOLT, FLANGE	2	
15	90185-12072-00	NUT, SELF-LOCKING	4	
16	J55-F2130-00-00	ARM SUB COMP 1	1	
17	90267-40131-00	RIVET, BLIND	9	

JF2100-0100

FRAME

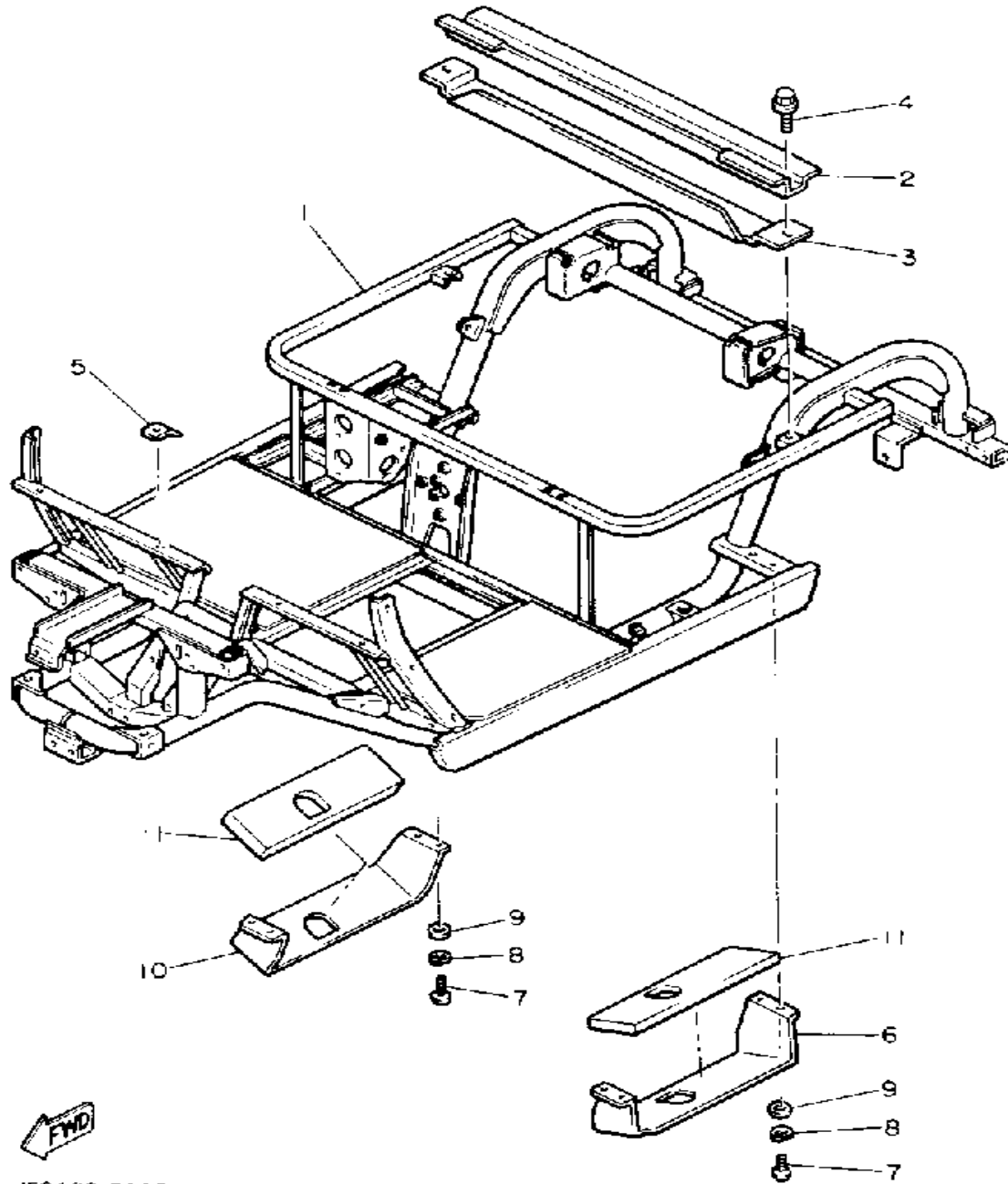

JF2100-0110

Ref. No.	Part Number	Description	Qty	Remarks
1	JF2-F2501-10-00	FRAME COMP.	1	
2	JF2-F254R-00-00	SUPPORT, BODY MOUNTING .	1	
3	JF2-K8266-00-00	PLATE, BODY PROTECT 6 ...	1	
4	95811-08016-00	BOLT, FLANGE	2	
5	JF2-7814A-00-00	SEAL, BODY UPPER	4	
6	JF2-F2592-00-00	PLATE 1	1	
7	98580-05012-00	SCREW, PAN HEAD	8	
8	92990-05100-00	WASHER, SPRING	8	
9	92901-05600-00	WASHER, PLATE	8	
10	JF2-F2593-00-00	PLATE 2	1	
11	JF2-K825H-00-00	PAD, SILENCER 4	2	

FRONT SUSPENSION-WHEEL

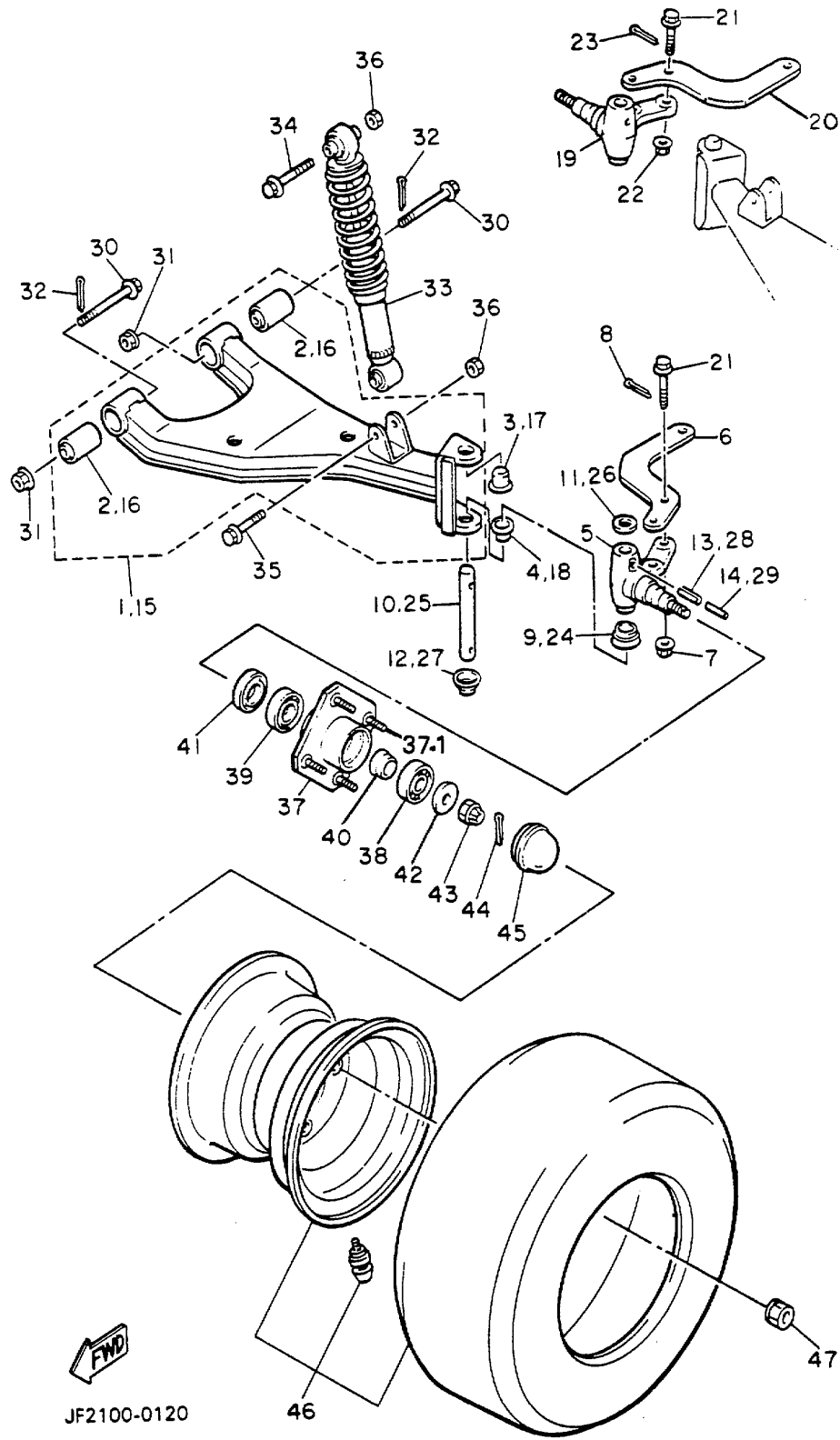

Ref. No.	Part Number	Description	Qty	Remarks
1	JF2-F3570-00-00	FRONT LOWER ARM COMP. (LEFT)	1	
2	J38-23526-00-00	. BUSH	2	
3	90338-17225-00	PLUG	1	
4	90386-15139-00	BUSH	1	
5	J38-23511-01-00	KNUCKLE, STEERING 1	1	
6	J38-23512-02-00	ARM, KNUCKLE 1	1	
7	90185-10115-00	NUT, SELF-LOCKING	2	
8	91401-25020-00	PIN, COTTER	2	
9	J38-23527-00-00	SEAL, DUST	1	
10	J38-23516-00-00	PIN, STEERING KNUCKLE	1	J38-23516-00
11	90201-156J2-00	WASHER, PLAIN	1	
12	J38-23528-00-00	SEAL, DUST	1	
13	91609-60028-00	PIN, SPRING	1	
14	91609-35028-00	PIN, SPRING	1	
15	JF2-F3580-00-00	FRONT LOWER ARM COMP. (RIGHT)	1	
16	J38-23526-00-00	. BUSH	2	
17	90338-17225-00	PLUG	1	
18	90386-15139-00	BUSH	1	
19	J38-23521-01-00	KNUCKLE, STEERING 2	1	
20	J38-23512-02-00	ARM, KNUCKLE 1	1	
21	90105-10360-00	BOLT, FLANGE	4	
22	90185-10115-00	NUT, SELF-LOCKING	2	
23	91401-25020-00	PIN, COTTER	2	
24	J38-23527-00-00	SEAL, DUST	1	
25	J38-23516-00-00	PIN, STEERING KNUCKLE	1	J38-23516-00
26	90201-156J2-00	WASHER, PLAIN	1	
27	J38-23528-00-00	SEAL, DUST	1	

CONTINUED ON NEXT FRAME ►

FRONT SUSPENSION-WHEEL

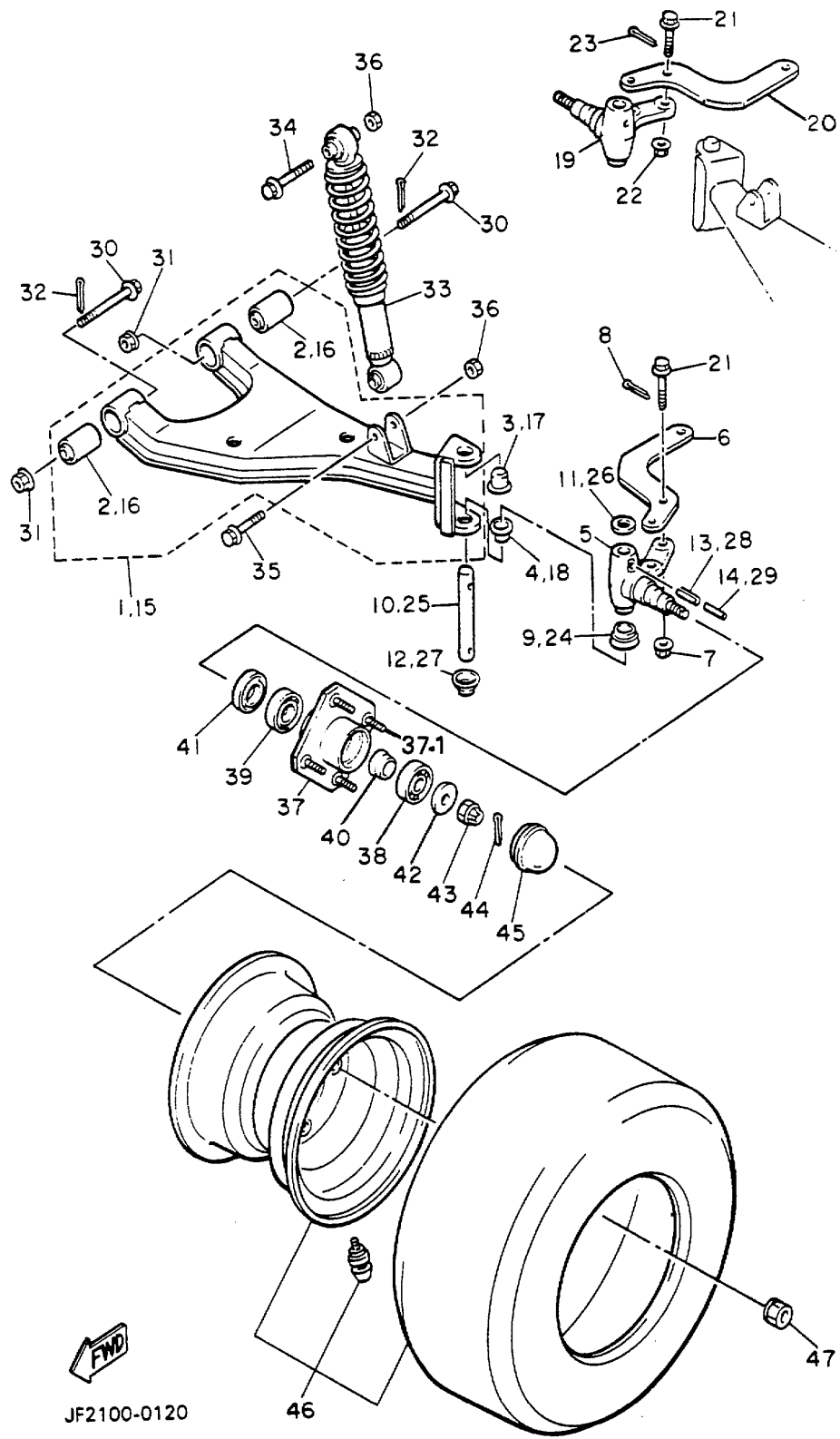

Ref. No.	Part Number	Description	Qty	Remarks
28	91609-60028-00	PIN, SPRING	1	
29	91609-35028-00	PIN, SPRING	1	
30	90105-10357-00	BOLT, FLANGE	4	
31	90185-10115-00	NUT, SELF-LOCKING	4	
32	91401-25020-00	PIN, COTTER	4	
33	JF2-23350-00-00	SHOCK ABSORBER ASSEMBLY	2	
34	97002-10065-00	BOLT	2	
35	97012-10050-00	BOLT (97002-10050-00)	2	
36	95601-10100-00	NUT, U (95602-10100-00)	4	
37	JG5-WF511-00-00	HUB	2	
38	93306-20437-00	BEARING	2	
39	93306-00511-00	BEARING	2	
40	90387-241M7-00	COLLAR	2	
41	93102-30083-00	SEAL, OIL	2	
42	90209-32271-00	WASHER	2	
43	95601-14100-00	NUT, U (95602-14100-00)	2	
44	91401-25020-00	PIN, COTTER	2	
45	J17-25118-00-00	COVER, HUB DUST	2	
46	JF2-F5100-00-00	FRONT WHEEL ASSEMBLY- 8	2	
47	90179-12262-00	NUT	8	
37-1	90114-12800-00	. BOLT, RIBBED NECK	8	

STEERING

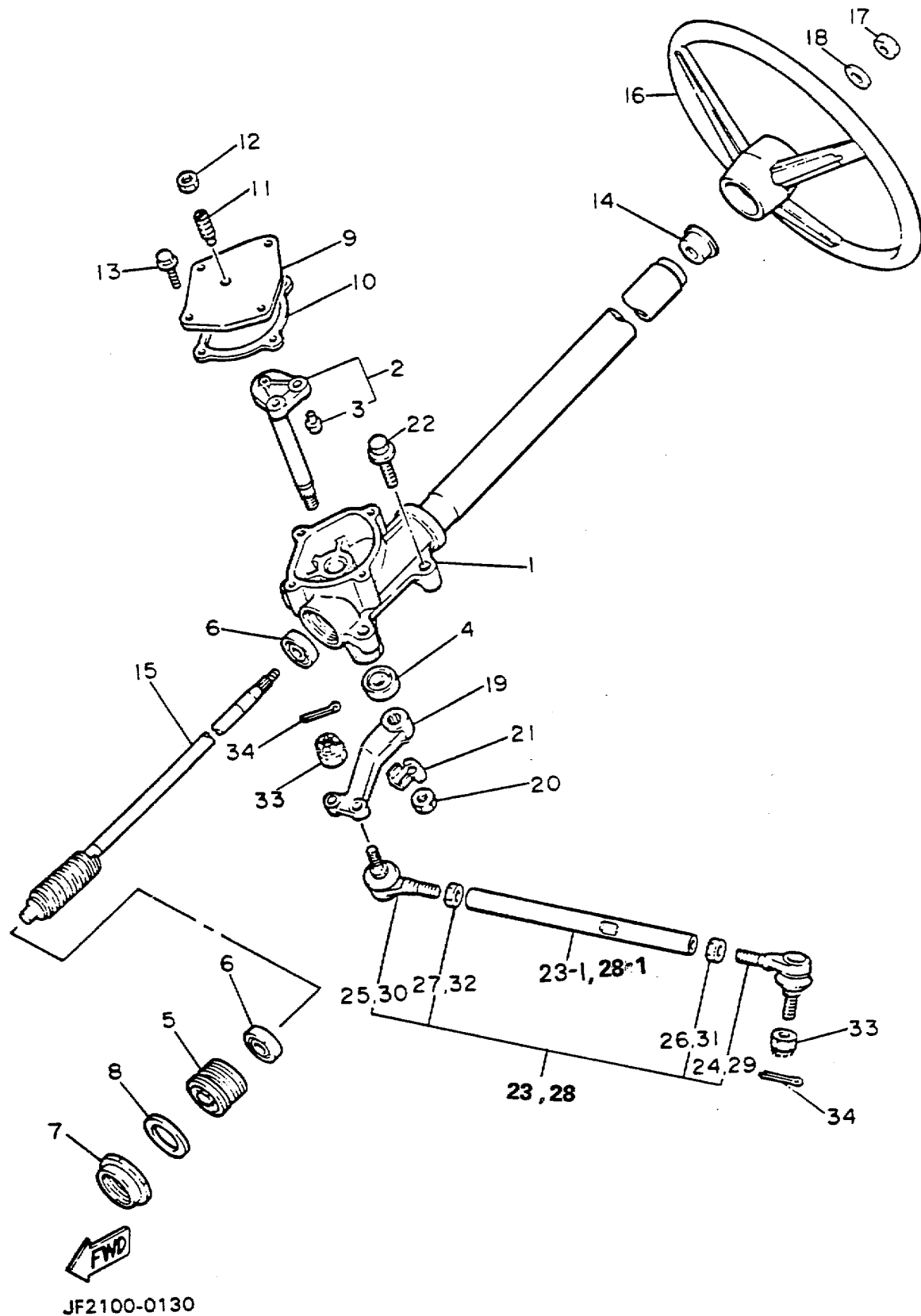

Ref. No.	Part Number	Description	Qty	Remarks
1	JG5-F3811-00-00	COLUMN, STEERING	1	
2	J38-23816-00-00	ARM, PITMAN	1	
3	J38-23836-00-00	. PIN, PITMAN	2	
4	93102-22314-00	SEAL, OIL	1	
5	J55-F3876-00-00	BOLT	1	
6	93332-00010-00	BEARING	2	
7	J10-23877-00-00	NUT	1	
8	J10-23444-00-00	WASHER	1	
9	J55-23818-00-00	COVER, STEERING	1	
10	J38-23462-00-00	SEAL, STEERING (J38-23462-01-00)	1	
11	J10-23459-00-00	BOLT	1	
12	90170-08024-00	NUT, HEX.	1	
13	95811-06020-00	BOLT, FLANGE	4	
14	J38-23814-00-00	HOLDER, HANDLE UPPER	1	
15	J10-23840-00-00	STEERING SHAFT	1	
16	JF2-F3838-00-00	WHEEL, STEERING	1	
17	90185-12119-00	NUT, SELF-LOCKING	1	
18	92990-12200-00	WASHER, PLAIN	1	
19	J38-23826-01-00	ARM, IDLER	1	
20	95701-16300-00	NUT, FLANGE	1	
21	90215-16252-00	WASHER, TONGUE	1	
22	95812-10050-00	BOLT, FLANGE	4	
23	JF2-F3830-00-00	TIE ROD ASSEMBLY	1	
24	J38-23841-01-00	. JOINT, UNIVERSAL 1	1	
25	J38-23845-01-00	. JOINT, UNIVERSAL 2	1	
26	90170-12055-00	. NUT	1	
27	90170-12054-00	. NUT	1	
28	JF2-F3850-00-00	TIE ROD ASSEMBLY	1	

CONTINUED ON NEXT FRAME ►

STEERING

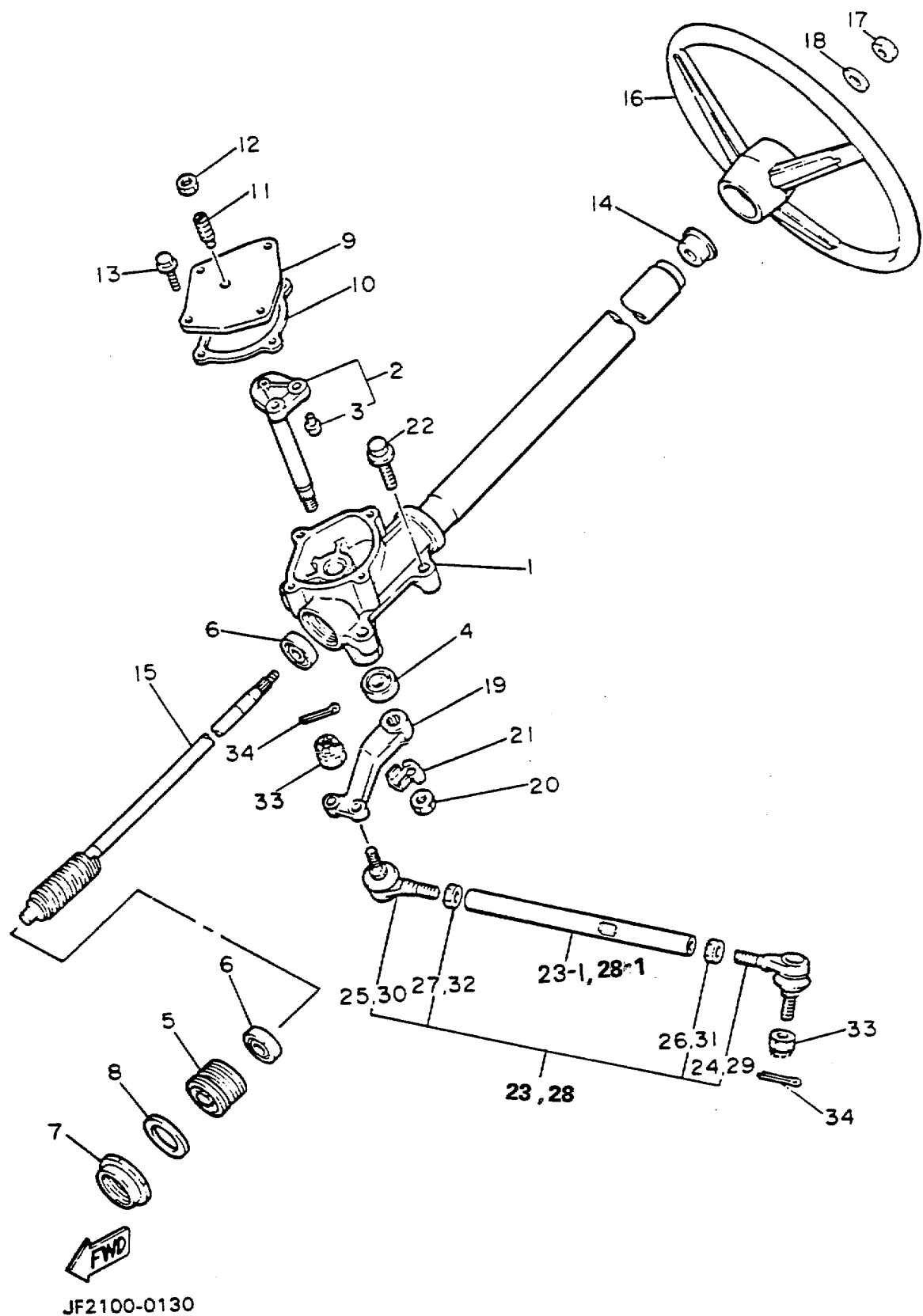

Ref. No.	Part Number	Description	Qty	Remarks
29	J38-23841-01-00	. JOINT, UNIVERSAL 1	1	
30	J38-23845-01-00	. JOINT, UNIVERSAL 2	1	
31	90170-12055-00	. NUT	1	
32	90170-12054-00	. NUT	1	
33	95601-10100-00	NUT, U (95602-10100-00)	4	
34	91401-25020-00	PIN, COTTER	4	
	G8A-PARTS-BO-AR	ASSEMBLY, HARDWARE (G8-A)	8	OPTIONAL PART
23-1	J38-23831-02-00	. ROD, TIE	1	
28-1	J38-23837-02-00	. ROD, TIE 2	1	

FUEL TANK

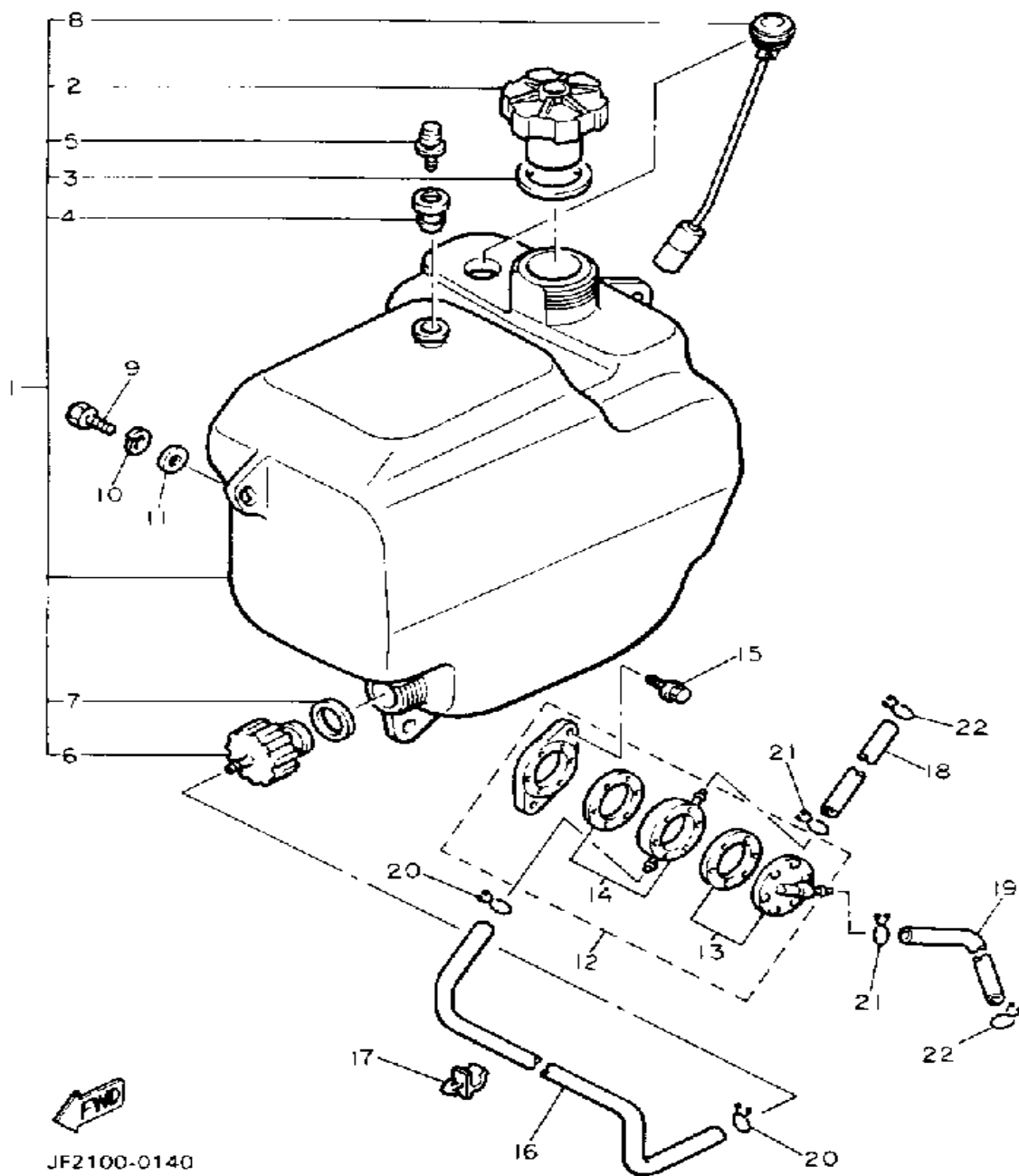

Ref. No.	Part Number	Description	Qty	Remarks
1	JF2-F4110-00-00	FUEL TANK COMP.	1	
2	J24-24620-01-00	. BODY CAP ASSEMBLY	1	
3	J10-24612-00-00	. GASKET, CAP	1	
4	JF2-21773-01-00	. GROMMET	1	
5	J24-24460-01-00	. RELEASE VALVE ASSEMBLY.	1	
6	8R4-24560-00-00	. FILTER ASSEMBLY.	1	
7	8F3-24564-00-00	. GASKET	1	
8	JF2-85710-00-00	. FUEL LEVEL GAUGE ASSEMBLY	1	
9	97313-08020-00	BOLT, HEXAGON	3	
10	92990-08100-00	WASHER	3	
11	90201-08748-00	WASHER, PLATE	3	
12	JF2-24410-10-00	FUEL PUMP ASSEMBLY	1	
13	J38-24452-18-00	. COVER, FUEL PUMP	1	
14	38W-W1391-01-00	. FUEL PUMP SEAL SET	1	
15	95811-06016-00	BOLT, FLANGE (95822-06016) .	2	
16	JF2-24311-00-00	PIPE, FUEL 1	1	
17	90464-11074-00	CLAMP	2	
18	90445-09304-00	HOSE	1	
19	90445-09085-00	HOSE	1	
20	90467-11009-00	CLIP	2	
21	90467-08017-00	CLIP	2	
22	90467-08017-00	CLIP	2	

BRAKE

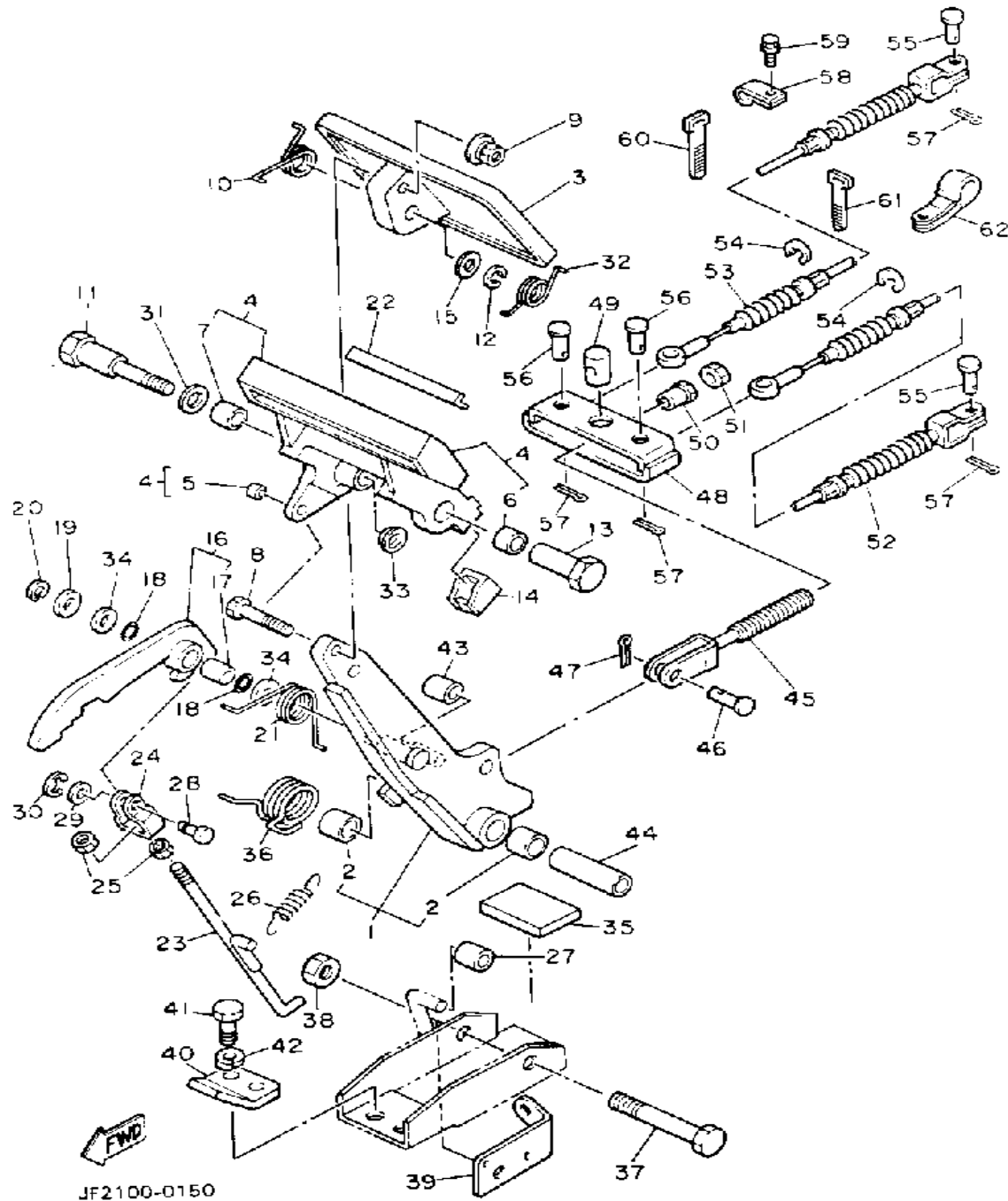

Ref. No.	Part Number	Description	Qty	Remarks
1	J46-27250-01-00	BRAKE ARM CMLPT	1	
2	90384-14080-00	. BUSH, BIMETAL	2	
3	J10-27211-00-00	PEDAL, BRAKE	1	
4	J17-25670-01-00	PARKING PEDAL COMP.	1	
5	90384-05163-00	. BUSH, BIMETAL	1	
6	90384-12164-00	. BUSH, BIMETAL	1	
7	90380-12051-00	. BUSH, SOLID	1	
8	90101-06555-00	BOLT, HEX.	1	
9	90179-07564-00	NUT	1	
10	90508-23542-00	SPRING, TORSION	1	
11	90109-08669-00	BOLT	1	
12	92990-08100-00	WASHER	1	
13	90179-08378-00	NUT	1	
14	J17-25679-01-00	DAMPER	2	
15	92990-08200-00	WASHER, PLAIN	1	
16	J17-W2561-00-00	SECTOR, PARKING BRAKE	1	
17	90384-10162-00	. BUSH, BIMETAL	1	
18	J17-27221-00-00	SEAL, SHAFT	2	
19	92990-10600-00	WASHER, PLATE	1	
20	99080-07600-00	CIRCLIP (E)	1	
21	90508-14548-00	SPRING, TORSION	1	
22	J17-25672-01-00	PAD, PARKING	1	
23	J17-27231-02-00	ROD, BRAKE	1	
24	J17-27232-00-00	END, ROD	1	
25	95380-06700-00	NUT	2	
26	90506-12277-00	SPRING, TENSION	1	
27	J17-25673-00-00	DAMPER, BRAKE	1	
28	J17-27228-00-00	PIN, LINK JOINT	1	
29	92901-05600-00	WASHER, PLATE	1	

CONTINUED ON NEXT FRAME ►

BRAKE

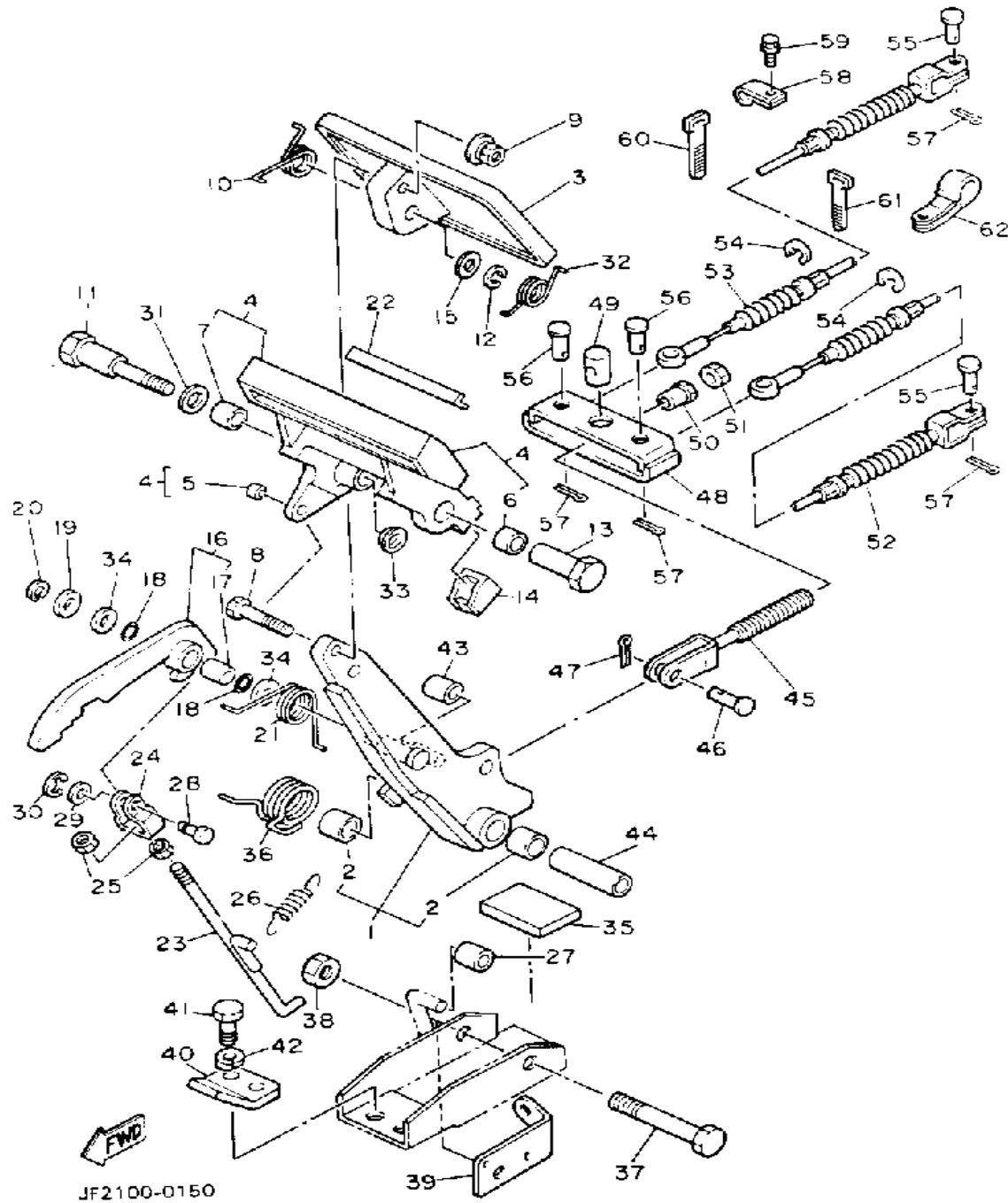

Ref. No.	Part Number	Description	Qty	Remarks
30	99080-04600-00	CIRCLIP (E)	1	
31	90201-123F2-00	WASHER, PLAIN	1	
32	90508-26557-00	SPRING, TORSION	1	
33	90380-12105-00	BUSH, SOLID	1	
34	90201-104G8-00	WASHER, PLAIN	2	
35	J17-27245-00-00	PAD, BRAKE PEDAL	1	
36	90508-40543-00	SPRING, TORSION	1	
37	90101-10447-00	BOLT, HEX.	1	
38	95601-10100-00	NUT, U (95602-10100-00)	1	
39	J55-2252M-00-00	BRACKET,	1	
40	J17-27246-00-00	NAIL, BRAKE	1	
41	97313-08020-00	BOLT, HEXAGON	2	
42	92990-08100-00	WASHER	2	
43	J17-25673-00-00	DAMPER, BRAKE	1	
44	90387-107F8-00	COLLAR	1	
45	JF2-25685-00-00	ROD	1	
46	91701-10022-00	PIN	1	
47	91490-30020-00	PIN, COTTER	1	
48	JF2-25681-00-00	EQUALIZER, BRAKE	1	
49	90249-14129-00	PIN	1	
50	90179-08261-00	NUT	1	
51	95303-08700-00	NUT	1	
52	JF2-F6341-00-00	CABLE, BRAKE	1	
53	JF2-F6351-00-00	CABLE, BRAKE	1	
54	99001-09600-00	CIRCLIP	4	
55	91701-08018-00	PIN	2	
56	91701-08026-00	PIN	2	
57	91490-25020-00	PIN, COTTER	4	
58	90461-12117-00	CLAMP	2	

CONTINUED ON NEXT FRAME ➤

BRAKE

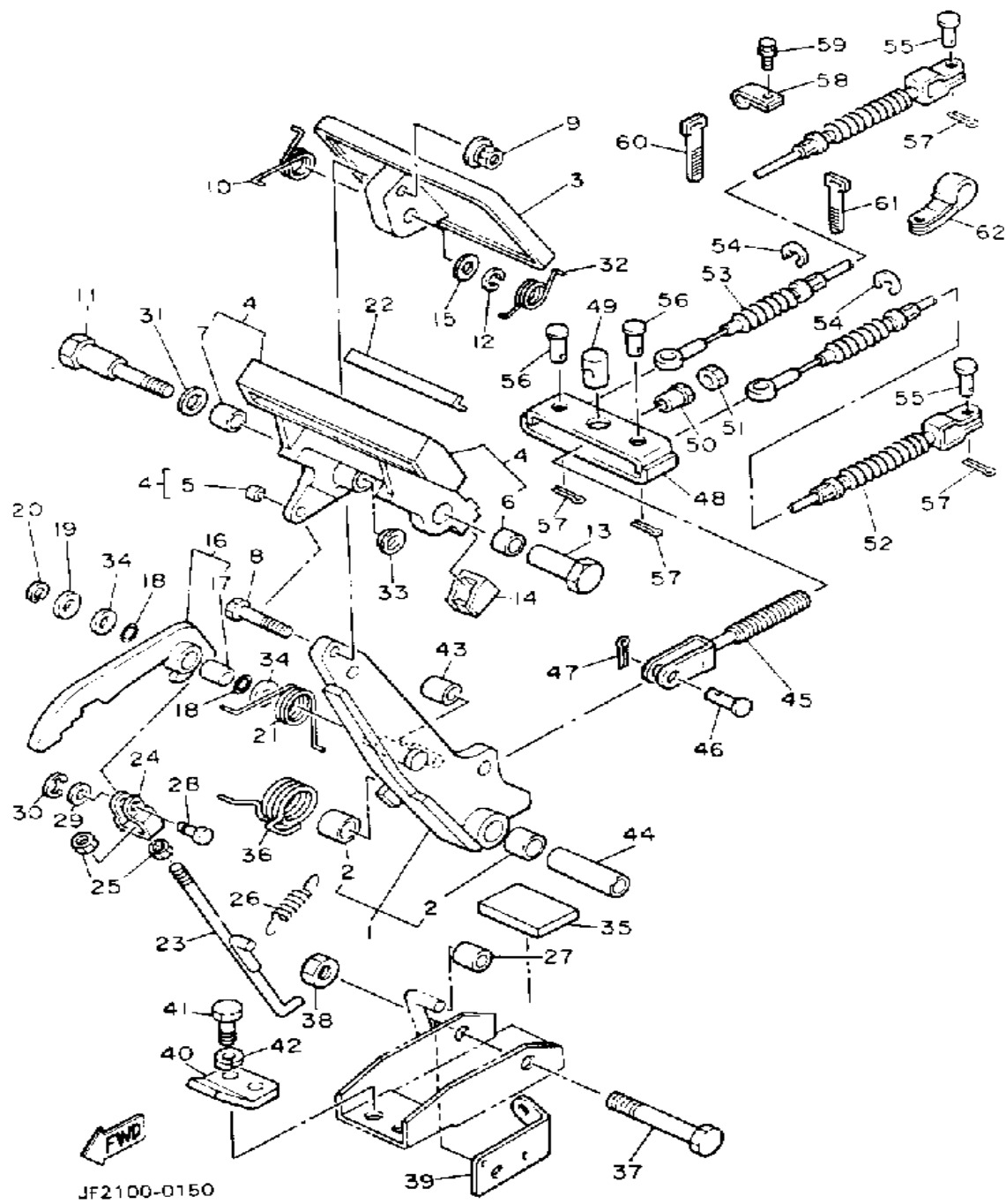

Ref. No.	Part Number	Description	Qty	Remarks
59	95811-06012-00	BOLT, FLANGE	2	
60	90465-13169-00	CALMP	1	
61	25G-83936-01-00	BAND, SWITCH CORD	1	
62	90461-08106-00	CLAMP	1	

BRAKE 2

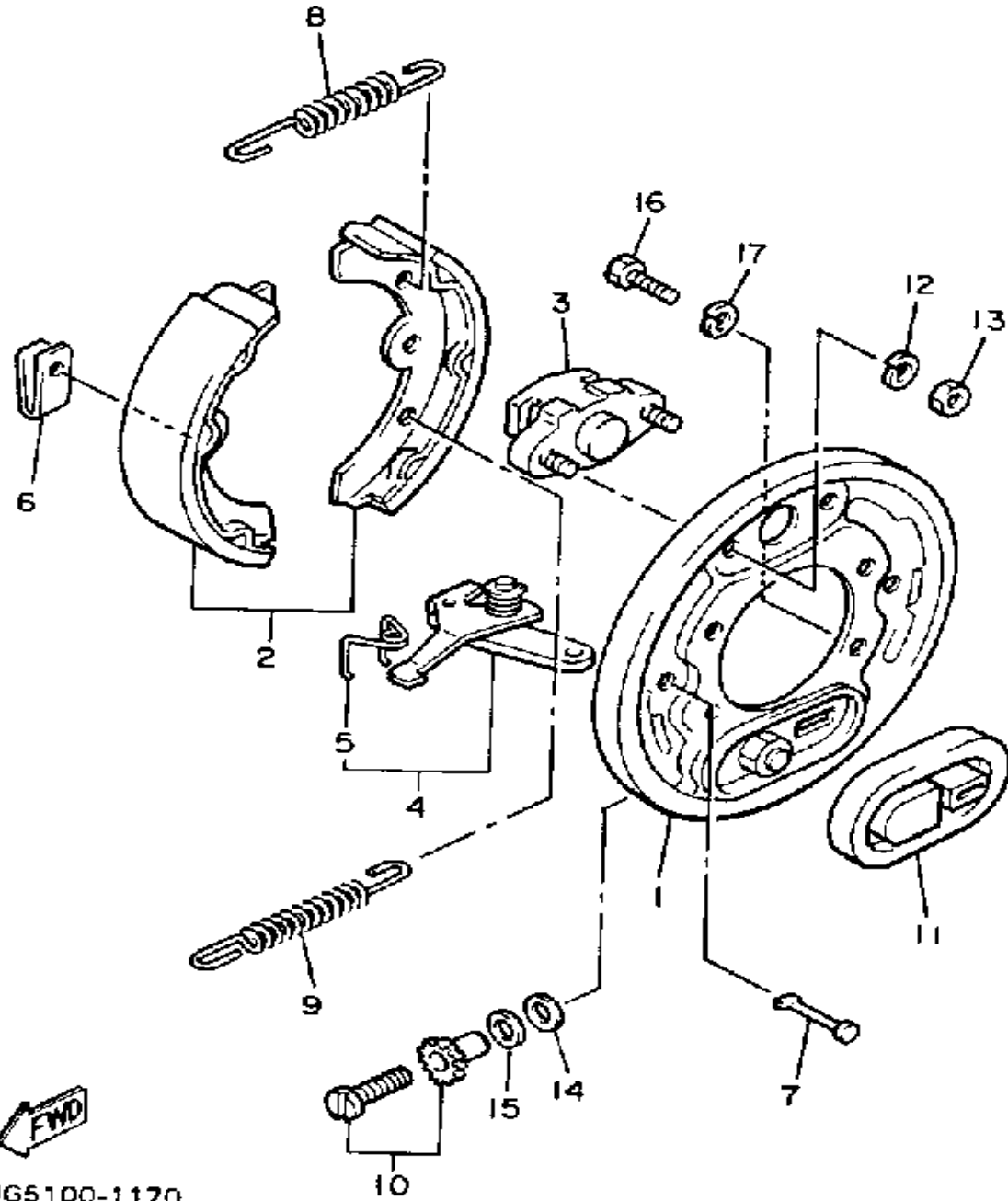

JG5100-1170

Ref. No.	Part Number	Description	Qty	Remarks
1	J17-27208-00-00	BACKING PLATE SUB ASSEMBLY 1 (R.H)	1	
2	J55-W2536-00-00	BRAKE SHOE SET	1	
3	J17-27206-00-00	ANCHOR BODY COMP.	1	
4	J38-27204-00-00	LEVER ASSEMBLY 1	1	
5	J55-25358-00-00	. SPRING LEVER	1	
6	J10-27281-00-00	SPRING, SHOE CLAMP	2	
7	J10-27282-00-00	PIN, SHOE HOLD DOWN	2	
8	90506-20281-00	SPRING, TENSION	1	
9	90506-26191-00	SPRING, TENSION	1	
10	J55-27270-00-00	ADJUSTER ASSEMBLY	1	
11	J10-27286-00-00	COVER, DUST	1	
12	92995-06100-00	WASHER, SPRING	2	
13	95380-06600-00	NUT	2	
14	90201-121H8-00	WASHER, PLATE	1	
15	90201-121H9-00	WASHER, PLATE	1	
16	97011-08016-00	BOLT	4	
17	92990-08100-00	WASHER	4	

BRAKE 3

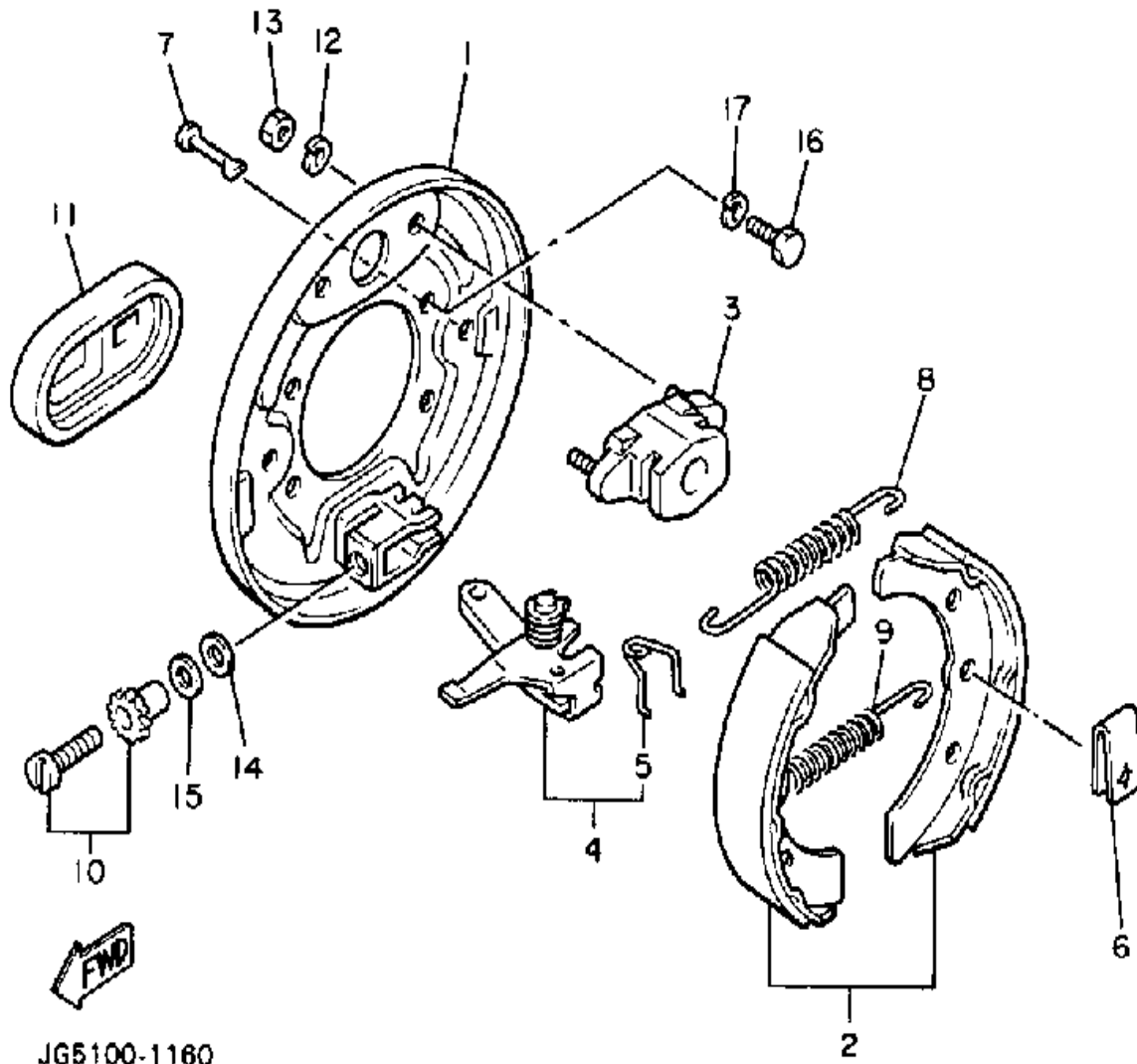

Ref. No.	Part Number	Description	Qty	Remarks
1	J17-27209-00-00	BACKING PLATE SUB ASSEMBLY 2 (L.H)	1	
2	J55-W2536-00-00	BRAKE SHOE SET	1	
3	J17-27206-00-00	ANCHOR BODY COMP.	1	
4	J38-27205-00-00	LEVER ASSEMBLY 2	1	
5	J55-25357-00-00	. SPRING, LEVER	1	
6	J10-27281-00-00	SPRING, SHOE CLAMP	2	
7	J10-27282-00-00	PIN, SHOE HOLD DOWN	2	
8	90506-20281-00	SPRING, TENSION	1	
9	90506-26191-00	SPRING, TENSION	1	
10	J55-27260-00-00	ADJUSTER ASSEMBLY	1	
11	J10-27286-00-00	COVER, DUST	1	
12	92995-06100-00	WASHER, SPRING	2	
13	95380-06600-00	NUT	2	
14	90201-121H8-00	WASHER, PLATE	1	
15	90201-121H9-00	WASHER, PLATE	1	
16	97011-08016-00	BOLT	4	
17	92990-08100-00	WASHER	4	

ACCELERATOR

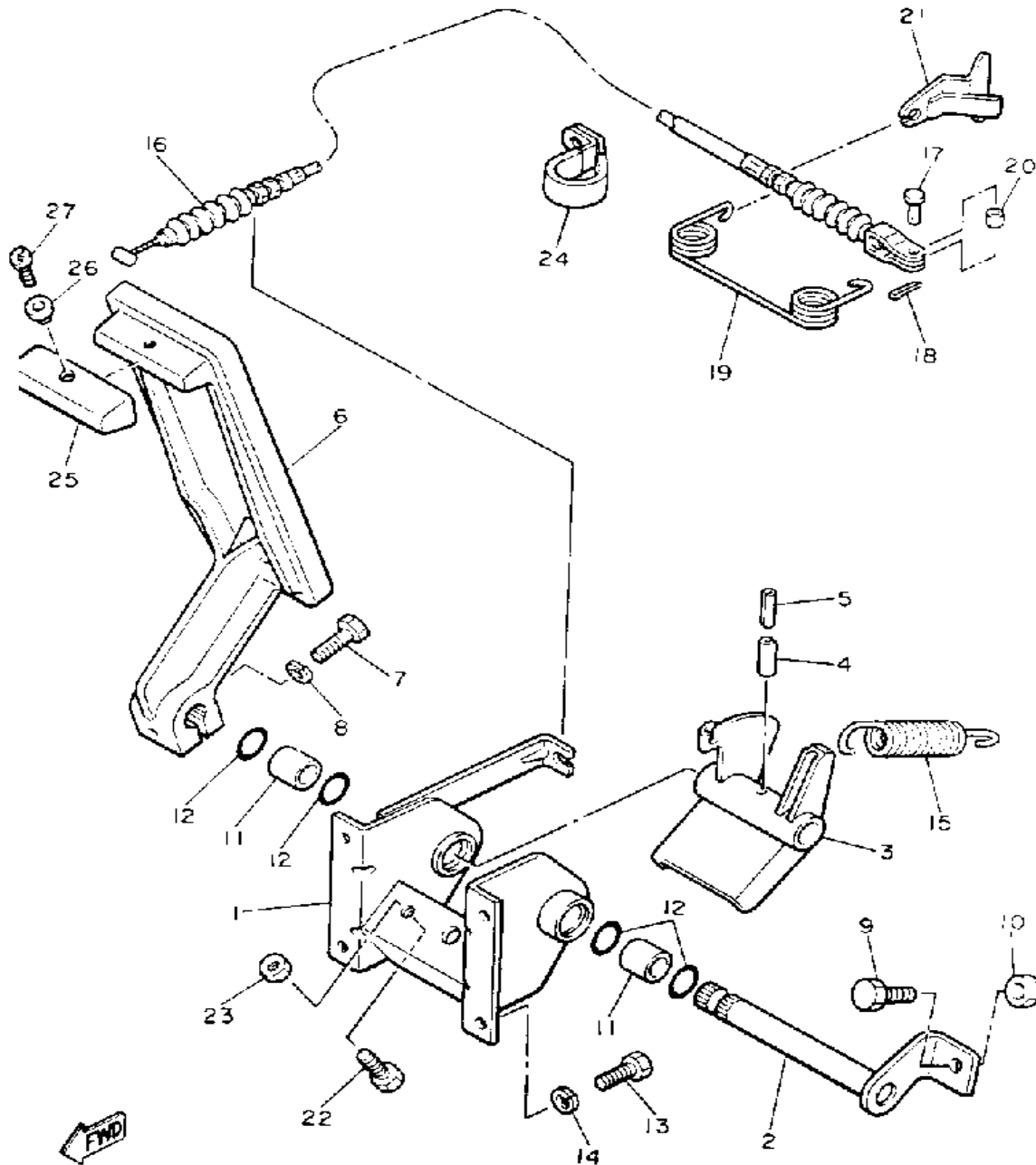

JF2100-0170

Ref. No.	Part Number	Description	Qty	Remarks
1	J38-27874-00-00	BRACKET, ACCELERATOR PEDAL	1	
2	J17-27853-00-00	SHAFT, PEDAL 1	1	
3	J38-27872-00-00	ARM, ACCELERATOR	1	
4	91609-60028-00	PIN, SPRING	1	
5	91609-35028-00	PIN, SPRING	1	
6	JF3-27871-00-00	PEDAL, ACCELERATOR	1	
7	97011-06025-00	BOLT (97001-06025)	1	
8	92995-06100-00	WASHER, SPRING	1	
9	90106-08040-00	BOLT, RD. HEX	1	
10	95303-08700-00	NUT	1	
11	90384-14080-00	BUSH, BIMETAL	2	
12	93210-14104-00	O-RING	4	
13	97011-06016-00	BOLT	4	
14	92995-06100-00	WASHER, SPRING	4	
15	90506-26282-00	SPRING, TENSION	1	
16	JF2-F6311-01-00	CABLE, THROTTLE 1	1	
17	91702-05012-00	PIN	1	
18	90468-10050-00	CLIP	1	
19	90508-16460-00	SPRING, TORSION	1	
20	90560-05001-00	SPACER	1	
21	J38-27981-00-00	BRACKET, THROTTLE	1	
22	97011-06025-00	BOLT (97001-06025)	1	
23	95380-06700-00	NUT	1	
24	90465-08334-00	CLAMP	1	
25	JF2-27854-00-00	COVER, PEDAL	1	
26	90387-050X4-00	COLLAR	1	
27	98906-05012-00	SCREW, BIND	1	

GOVERNOR

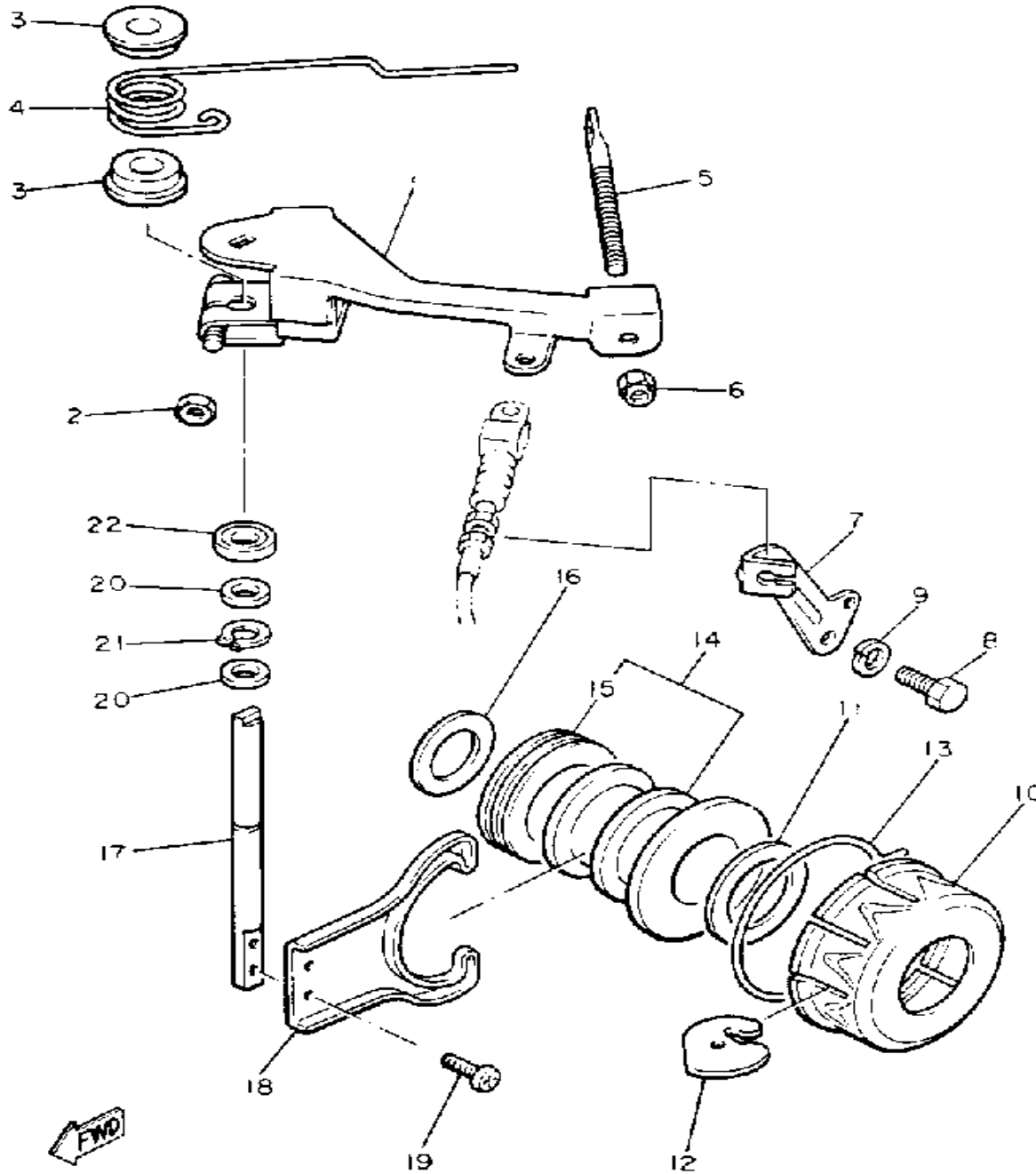

JF2100-0180

Ref. No.	Part Number	Description	Qty	Remarks
1	J38-27951-00-00	LEVER, SPEED	1	
2	95380-06600-00	NUT	1	
3	90386-08141-00	BUSH	2	
4	90508-40678-00	SPRING, TORSION	1	
5	J38-27959-00-00	SCREW, ADJUSTING	1	
6	95701-06300-00	NUT, NYLON	1	
7	J38-27982-00-00	BRACKET, WIRE	1	
8	97011-08016-00	BOLT	1	
9	92990-08100-00	WASHER	1	
10	J10-27912-00-00	RETAINER	1	
11	90387-21690-00	COLLAR	1	
12	J10-27913-00-00	WEIGHT	12	
13	J10-27911-00-00	HOLDER	1	
14	J10-27927-00-00	LIFTER	1	
15	93342-22502-00	. BEARING, THRUST	1	
16	90201-20275-00	WASHER, PLATE	1	
17	J38-27921-00-00	SHAFT, GOVERNOR	1	
18	J10-27922-00-00	FORK, GOVERNOR	1	
19	90157-04092-00	SCREW, PAN HEAD	2	
20	90202-08110-00	WASHER, PLATE	2	
21	99009-06600-00	CIRCLIP	1	
22	93109-08050-00	OIL SEAL	1	

PRIMARY SHEAVE

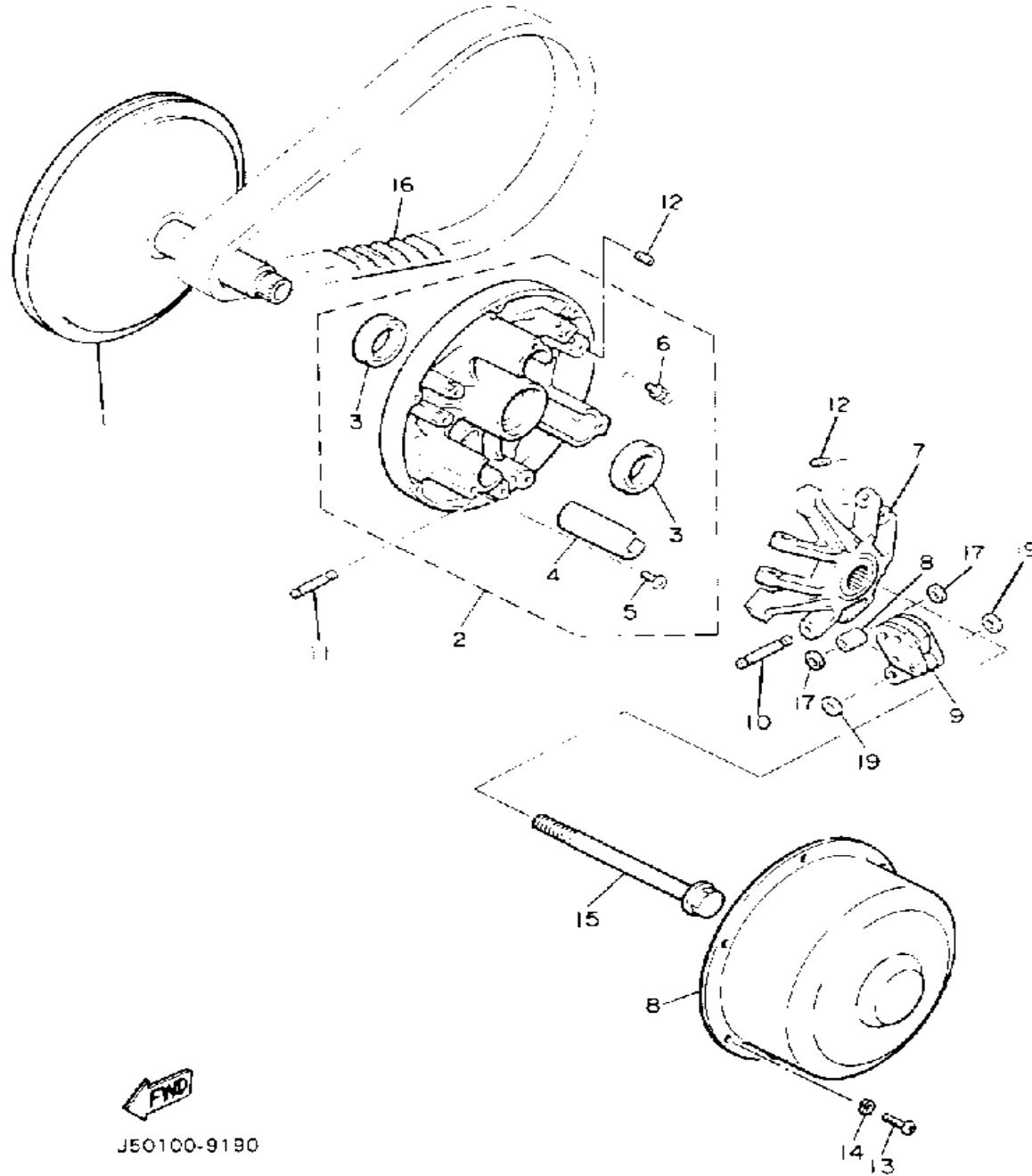

Ref. No.	Part Number	Description	Qty	Remarks
1	J38-46210-00-00	PRIMARY FIXED	1	
2	J38-46220-00-00	PRIMARY SLIDING SHEAVE COMP.	1	
3	93102-28348-00	. OIL SEAL	2	
4	J38-46253-00-00	. SLIDER	3	
5	98901-05008-00	. SCREW, BIND	3	
6	93700-06M03-00	. NIPPLE, GREASE	1	
7	J38-46251-00-00	SPIDER	1	
8	J38-46231-00-00	CAP	1	
9	J38-46205-01-00	WEIGHT LINK ASSEMBLY	3	
10	J38-46236-00-00	PIN, WEIGHT	3	
11	J38-46237-00-00	PIN, WEIGHT 2	3	
12	90113-04050-00	BOLT, SET	12	
13	98580-05010-00	SCREW, PAN HEAD	6	
14	92990-05100-00	WASHER, SPRING	6	
15	J38-46249-00-00	BOLT	1	
16	J55-G6241-00-00	BELT	1	J38-46241-00
17	90202-07164-00	WASHER, PLATE	6	
18	90387-076U6-00	COLLAR	3	
19	90202-07186-00	WASHER, PLATE	6	

FWD
J50100-9190

SECONDARY SHEAVE

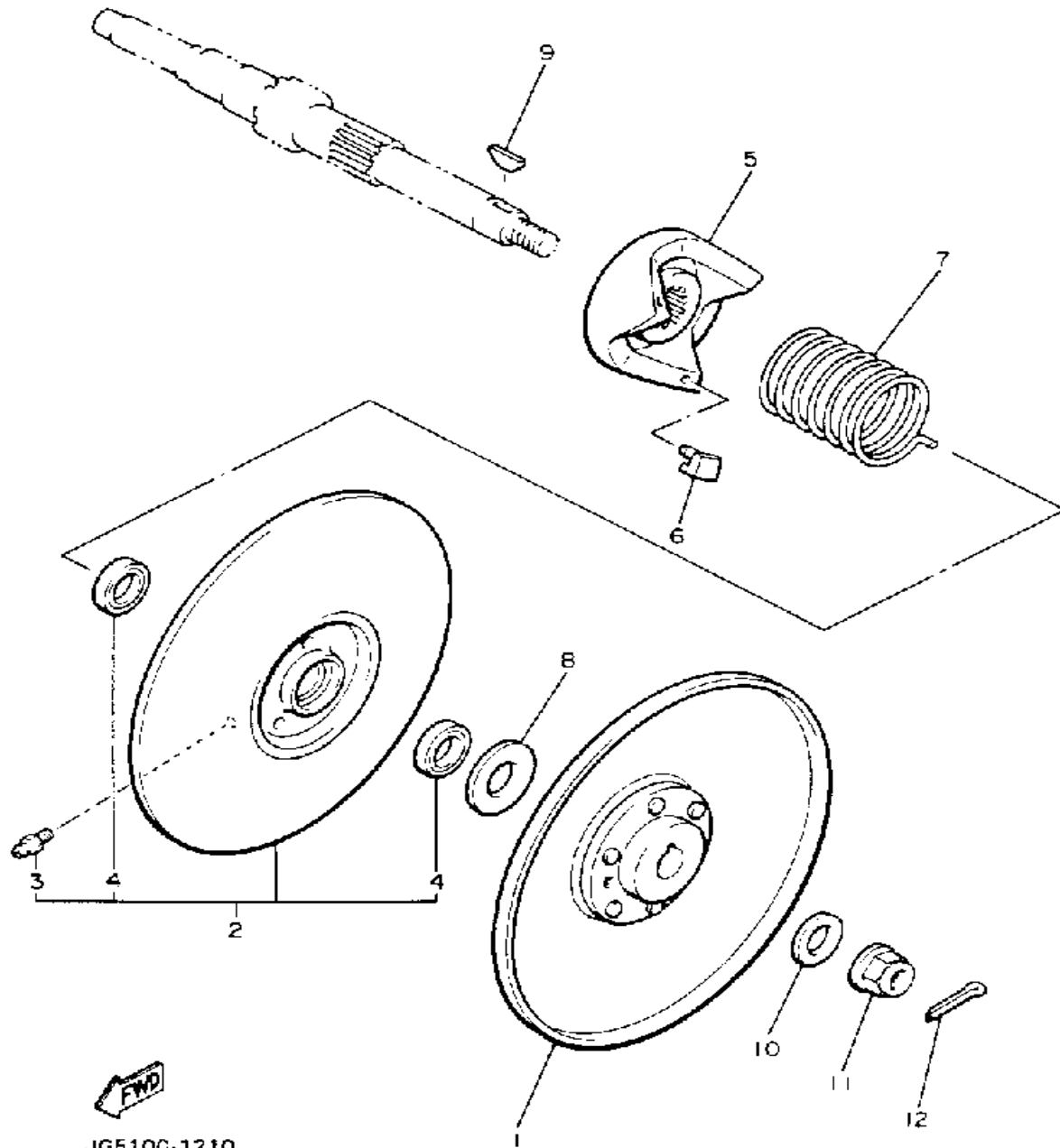

Ref. No.	Part Number	Description	Qty	Remarks
1	J55-G6260-00-00	SECONDARY FIXED SHEAVE COMP.	1	
2	J55-G6270-02-00	SECONDARY SLIDING SHEAVE COMP.	1	
3	93700-06M03-00	. NIPPLE, GREASE	1	
4	93102-20309-00	. SEAL, OIL	2	
5	J38-46284-00-00	SEAT, SEC SPRING	1	
6	801-17688-10-00	SHOE, RAMP	3	
7	90508-45679-00	SPRING, TORSION	1	
8	90202-20130-00	WASHER, PLAIN	1	
9	90280-05022-00	KEY, WOODRUFF	1	
10	90201-12588-00	WASHER, PLATE	1	
11	95601-12200-00	NUT, SELF-LOCKING	1	
12	91401-25030-00	PIN, COTTER	1	

JG510C-1210

TRANSMISSION 1

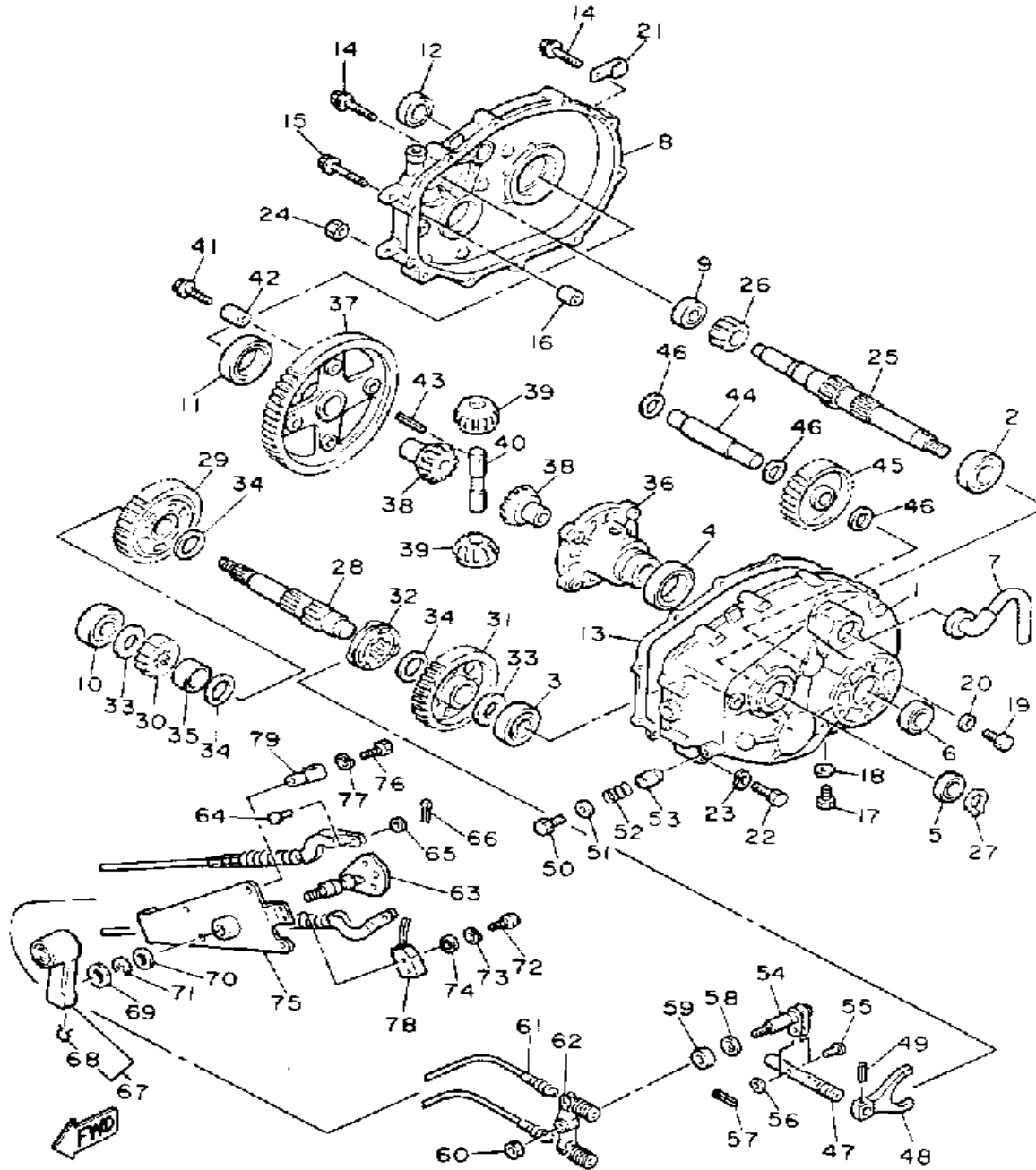

JF2100-0210

Ref. No.	Part Number	Description	Qty	Remarks
1	J38-46311-00-00	CASE, TRANSMISSION 1	1	
2	93306-20541-00	BEARING (B6205)	1	
3	93306-20421-00	BEARING	1	
4	93306-00803-00	BEARING (B6008)	1	
5	93102-25017-00	OIL SEAL	1	
6	93102-22189-00	OIL SEAL	1	
7	835-47559-00-00	CAP 2	1	
8	J38-46312-00-00	CASE, TRANS 2	1	
9	93306-20324-00	BEARING	1	
10	93306-20421-00	BEARING	1	
11	93306-00803-00	BEARING (B6008)	1	
12	93102-22189-00	OIL SEAL	1	
13	J38-46319-01-00	GASKET	1	
14	95811-08040-00	BOLT, FLANGE	7	
15	95811-08050-00	BOLT, FLANGE (95812-08050)	2	
16	99510-12016-00	PIN, DOWEL	2	
17	90340-14036-00	PLUG, STRAIGHT SCRW	1	
18	90430-14043-00	GASKET	1	
19	90101-08344-00	BOLT	1	
20	90201-08087-00	WASHER, PLATE	1	
21	90465-06100-00	CLAMP	1	
22	97022-08075-00	BOLT	1	
23	92990-08100-00	WASHER	1	
24	95333-08600-00	NUT	1	
25	J38-46321-02-00	SHAFT, INPUT	1	
26	J38-46331-01-00	GEAR, INPUT 1	1	
27	93410-25017-00	CIRCLIP	1	
28	J38-46351-00-00	SHAFT, COUNTER	1	
29	J38-46361-01-00	GEAR, COUNTER 1	1	

CONTINUED ON NEXT FRAME ►

TRANSMISSION 1

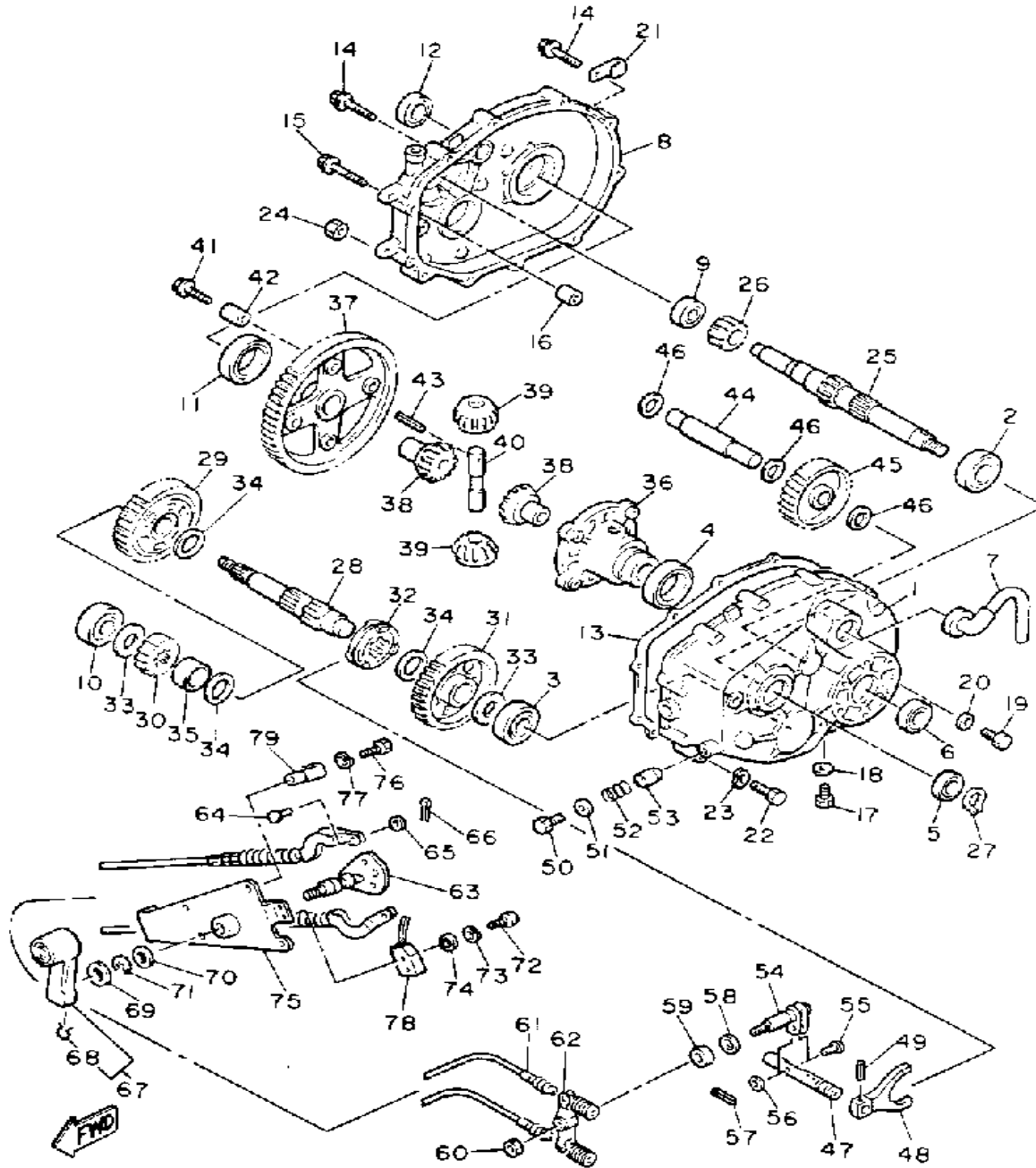

JF2100-0210

Ref. No.	Part Number	Description	Qty	Remarks
30	J38-46362-00-00	GEAR, COUNTER 2	1	
31	J38-46363-00-00	GEAR, REVERSE	1	
32	J38-4636A-00-00	DOG, CLUTCH	1	
33	90201-204K8-00	WASHER, PLATE	2	
34	90201-257J2-00	WASHER, PLATE	3	
35	90387-252M8-00	COLLAR	1	
36	J38-46411-01-00	CASE, DIFFERENTIAL	1	
37	J38-46421-01-00	GEAR, RING	1	
38	J38-46414-00-00	GEAR, DIFFERENTIAL SIDE	2	
39	J38-46415-00-00	PINION, DIFFERENTIAL	1	
40	J38-46417-02-00	PIN, DIFFERENTIAL	1	
41	90105-08390-00	BOLT, WASHER BASED	4	
42	91812-16001-00	PIN, DOWEL	2	
43	91609-40040-00	PIN, SPRING	1	
44	J38-46348-00-00	SHAFT 2	1	
45	J38-46356-00-00	GEAR, IDLER	1	
46	90201-17713-00	WASHER, PLATE	3	
47	J38-4633A-00-00	BAR, SHIFT FORK GUIDE	1	
48	J38-46338-00-00	FORK, SHIFT	1	
49	91609-40020-00	PIN, SPRING	1	
50	90101-08344-00	BOLT	1	
51	90201-08087-00	WASHER, PLATE	1	
52	90501-10060-00	SPRING, COMPRESSION	1	
53	90249-07215-00	PIN	1	
54	J38-46384-00-00	LEVER, SHIFT 3	1	
55	91701-06022-00	PIN, CLEVIS	1	
56	92990-06200-00	WASHER	1	
57	91490-20020-00	PIN, COTTER	1	
58	90201-12166-00	WASHER, PLATE	1	

CONTINUED ON NEXT FRAME ➤

TRANSMISSION 1

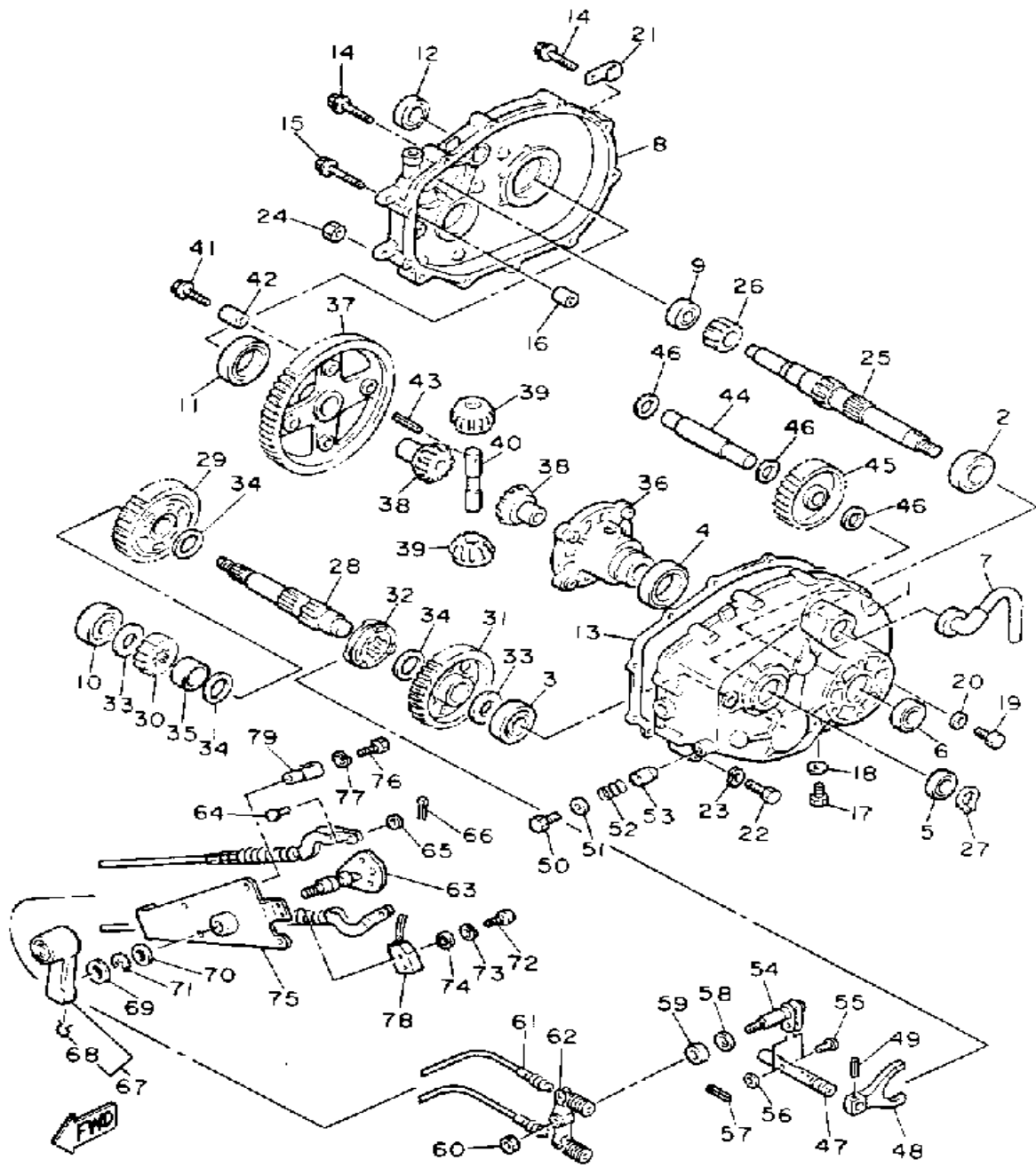

JF2100-0210

Ref. No.	Part Number	Description	Qty	Remarks
59	93102-12224-00	OIL SEAL	1	
60	95611-08100-00	NUT, U	1	
61	J55-G6371-00-00	SHIFT WIRE	2	J38-46371-01
62	J55-G6383-00-00	LEVER, SHIFT	1	J38-46383-00
63	JF2-46382-00-00	LEVER, SHIFT	1	
64	91702-06014-00	PIN	2	
65	92990-06600-00	WASHER, PLATE	2	
66	91490-20020-00	PIN, COTTER	2	
67	JF2-46370-00-00	SHIFT ASSEMBLY	1	
68	JF2-46376-00-00	. SPRING	1	
69	90201-201L9-00	WASHER, PLAIN	1	
70	90201-19551-00	WASHER, PLAIN	1	
71	99009-19400-00	CIRCLIP	1	
72	97802-04016-00	SCREW, PAN HEAD	2	
73	92901-04100-00	WASHER, SPRING	2	
74	92901-04600-00	WASHER, PLATE	2	
75	JF2-46372-00-00	BRACKET, SHIFT WIRE	1	
76	97011-06016-00	BOLT	4	
77	92995-06100-00	WASHER, SPRING	4	
78	J50-82617-00-00	SWITCH	1	
79	90465-06038-00	CLAMP	1	

REAR AXLE-WHEEL

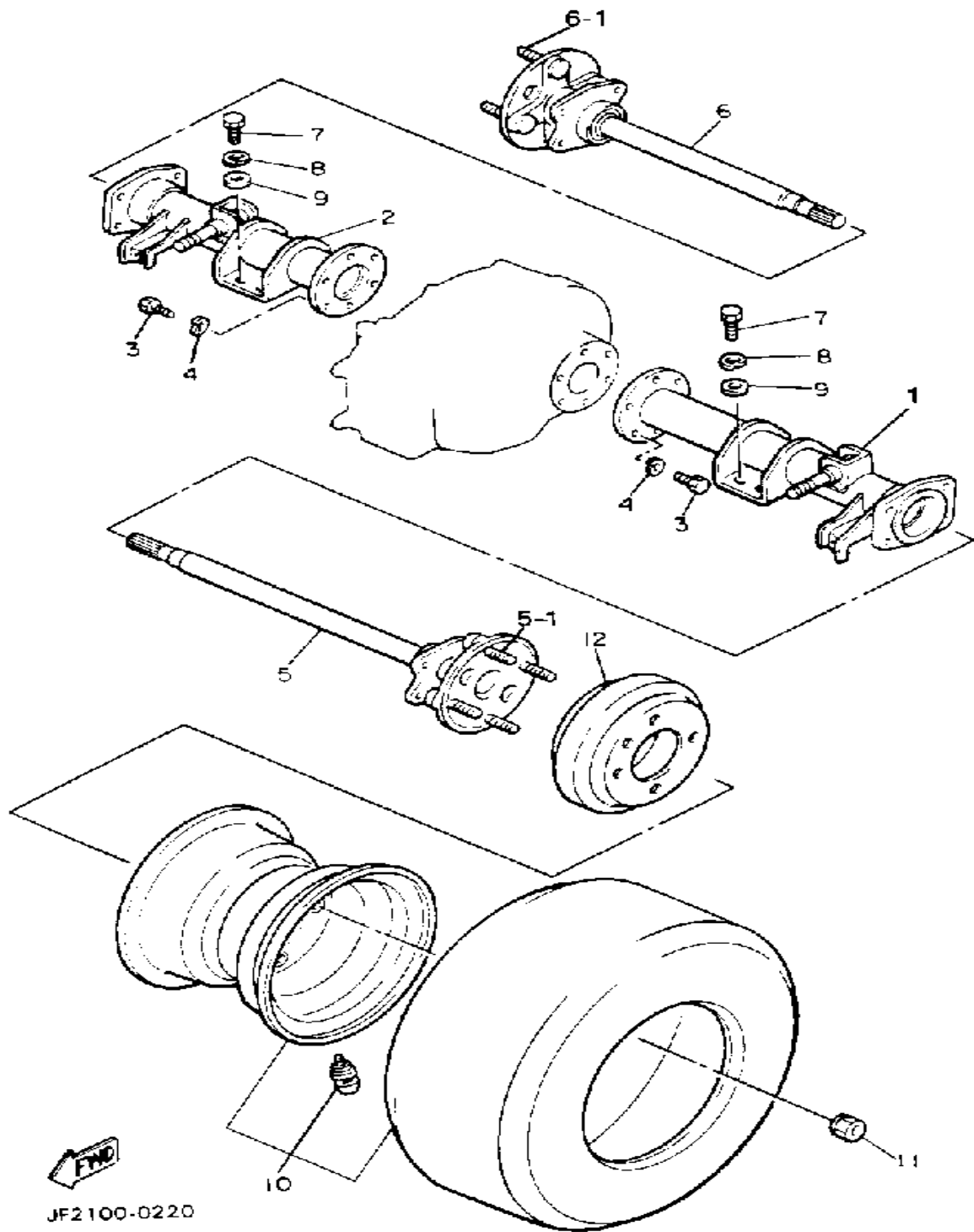

Ref. No.	Part Number	Description	Qty	Remarks
1	JF2-46540-00-00	R.AXLE HOUSING 1	1	
2	JF2-46550-00-00	R.AXLE HOUSING 2COMP. 2	1	
3	97011-08025-00	BOLT	12	
4	92990-08100-00	WASHER	12	
5	JF2-46510-00-00	REAR AXLE SHAFT COMP.	1	
6	JF2-46520-00-00	REAR AXLE SHAFT COMP. 2	1	
7	97011-10020-00	BOLT	8	
8	92901-10100-00	WASHER, SPRING	8	
9	92990-10600-00	WASHER, PLATE	8	
10	JF2-F5100-00-00	FRONT WHEEL ASSEMBLY- 8	2	
11	90179-12262-00	NUT	8	
12	J55-G6521-00-00	DRUM	2	J17-46521-00
5-1	90114-12004-00	. BOLT, RIBBED NECK	4	
6-1	90114-12004-00	. BOLT, RIBBED NECK	4	

JF2100-0220

BUMPER

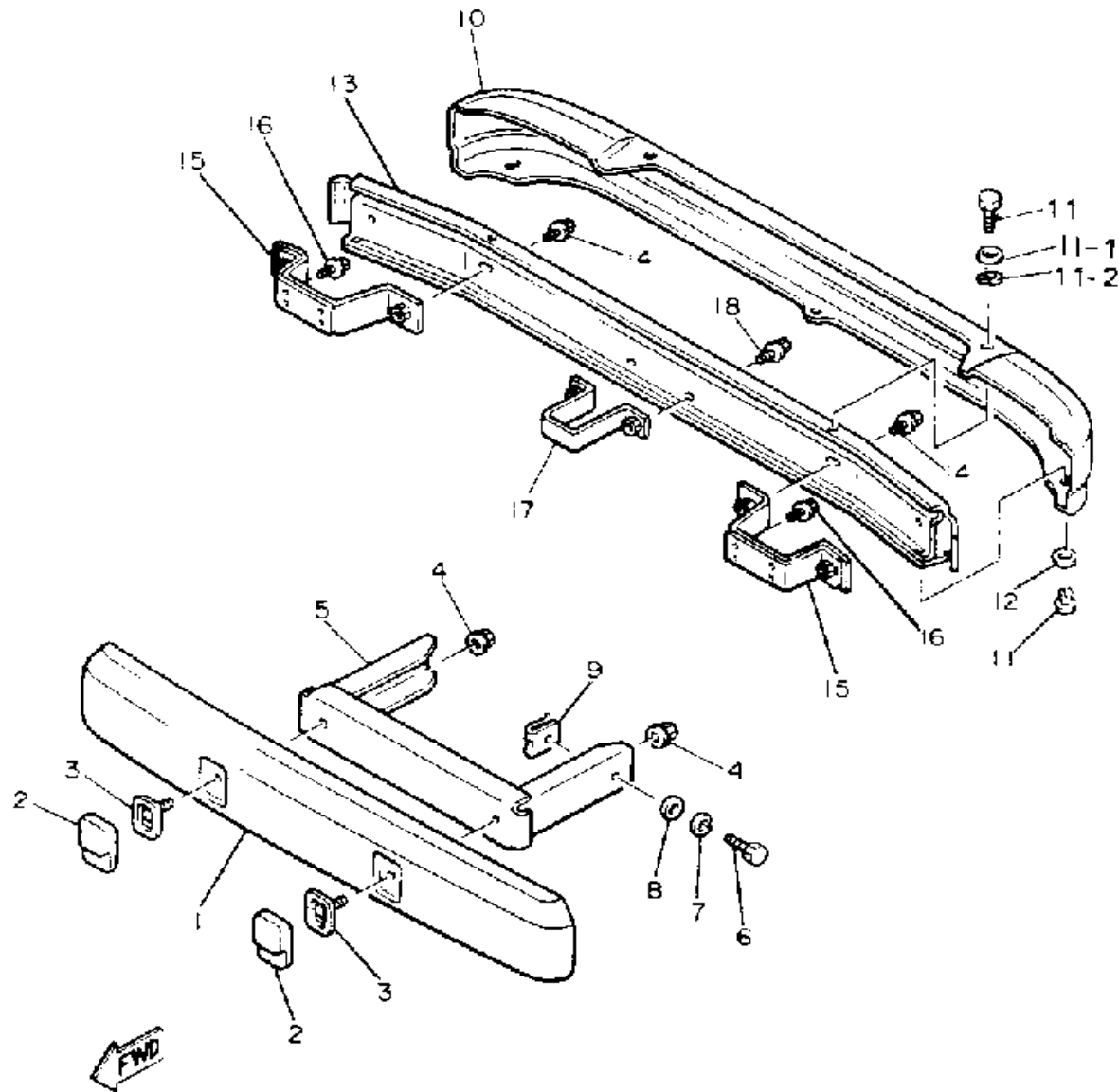

JF2100-0230

Ref. No.	Part Number	Description	Qty	Remarks
1	JF2-K8163-01-00	COVER, BUMPER	1	
2	JF2-77517-00-00	CAP	2	
3	JF2-77527-00-00	PLATE, BACK UP	2	
4	95706-08500-00	NUT, flange	2	
5	JF2-K7511-00-00	BUMPER, FRONT 1	1	
6	97313-08020-00	BOLT, HEXAGON	2	
7	92990-08100-00	WASHER	2	
8	92990-08600-00	WASHER, PLATE	2	
9	JF2-77528-00-00	NUT	2	
10	JF2-K817U-00-00	COVER, REAR BUMPER	1	
11	97706-50516-00	SCREW, TAPPING	5	
12	90201-063J2-00	WASHER, PLATE	2	
13	JF2-K8107-00-00	BUMPER SUB-ASSEMBLY, REAR	1	
14	95816-08016-00	BOLT, FLANGE	4	
15	JF2-K8174-00-00	STAY, REAR BUMPER	2	
16	95816-08016-00	BOLT, FLANGE	6	
17	JF2-K7521-00-00	STOPPER, 1	1	
18	95816-08016-00	BOLT, FLANGE	2	
	G8A-PARTS-BO-AR	ASSEMBLY, HARDWARE (G8-A)	8	OPTIONAL PART
11-1	90201-05033-00	WASHER, PLATE	5	
11-2	90183-05042-00	NUT, SPRING	5	

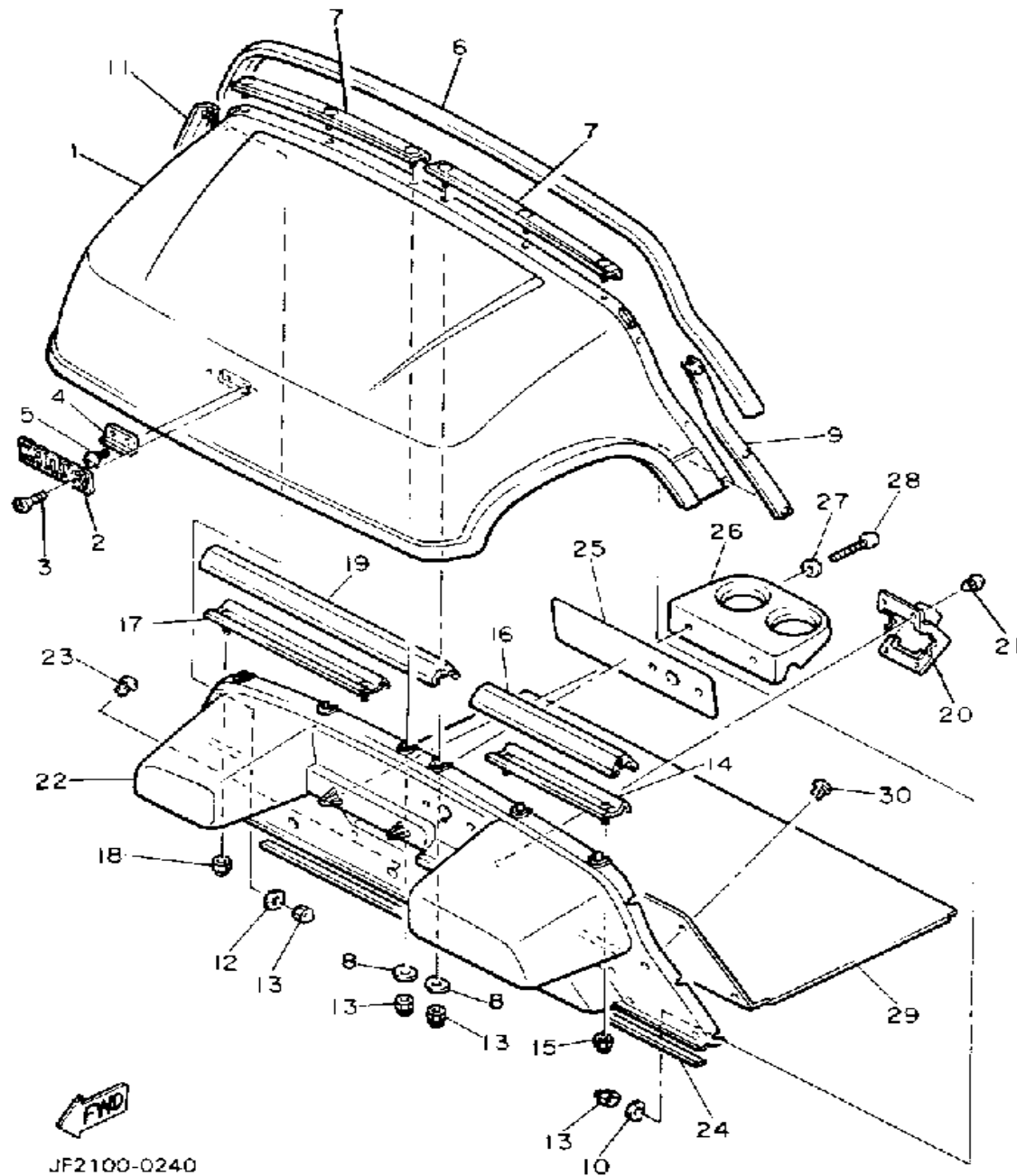

BODY

Ref. No.	Part Number	Description	Qty	Remarks
1	JF2-K8115-00-00	COWL, FRONT	1	
2	J38-24161-00-00	EMBLEM 1	1	
3	90162-04002-00	SCREW, OVAL C	2	
4	JF2-K811G-00-00	BOLT, COWL FITTING	1	
5	98980-06016-00	SCREW, BINDING	2	
6	JF2-K811V-00-00	PROTECTOR,	1	
7	JF2-K8261-00-00	PLATE, BODY PROTECTOR ..	2	
8	JF2-78117-00-00	PLATE 1	6	
9	JF2-K8262-00-00	PLATE, BODY PROTECTOR ..	1	
10	JF2-78117-00-00	PLATE 1	3	
11	JF2-K8263-00-00	PLATE, BODY PROTECTOR ..	1	
12	JF2-78117-00-00	PLATE 1	3	
13	90176-06069-00	NUT, CROWN	12	
14	JF2-K8264-00-00	PLATE, BODY PROTECTOR ..	1	
15	95601-06100-00	NUT, U	2	
16	JF2-K811W-00-00	PROTECTOR 2	1	
17	JF2-K8265-00-00	PLATE, BODY PROTECTOR 5 .	1	
18	95601-06100-00	NUT, U	2	
19	JF2-7811X-00-00	PROTECTOR 3	1	
20	JF2-78273-00-00	COVER, HOLE	1	
21	90269-11042-00	RIVET	4	
22	JF2-K8114-00-00	PANEL, FRONT	1	
23	90269-08069-00	RIVET	3	
24	JF2-7815G-00-00	SEAL, FRONT STORAGE	1	
25	JF2-77768-01-00	LABEL, WARNING	1	
26	JF2-K835E-00-00	HOLDER, BEVERAGE	1	
27	90201-060A3-00	WASHER, PLATE	2	
28	97702-60130-00	SCREW, TAPPING	2	
29	JF2-K8233-00-00	MAT, MAIN FLOOR 3	1	

CONTINUED ON NEXT FRAME ►

BODY

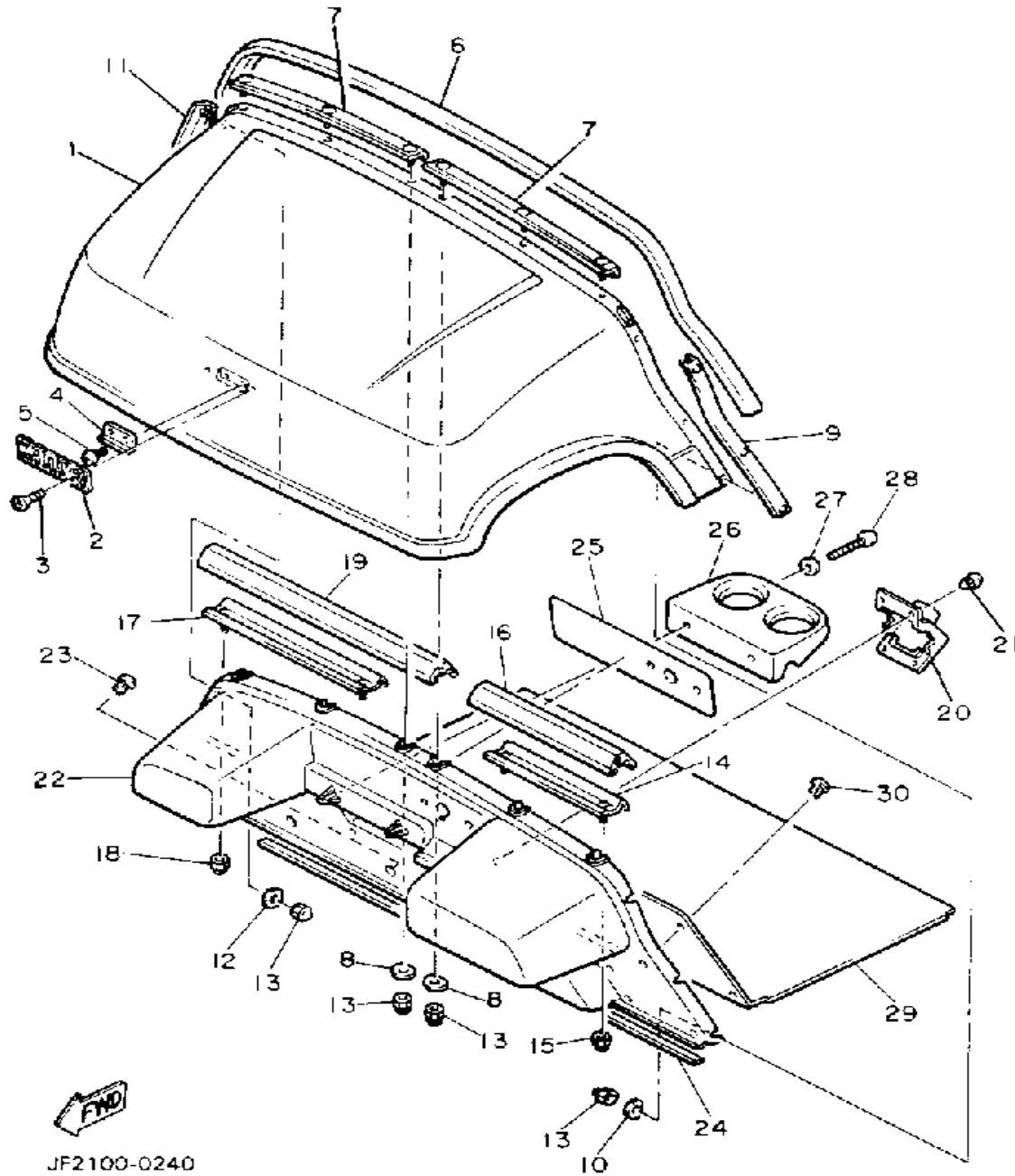

Ref. No.	Part Number	Description	Qty	Remarks
30	90267-63047-00	RIVET, BLIND	11	
	PNT-90000-K0-91	PAINT		PALE ALMONDOPTIONAL PART

BODY 2

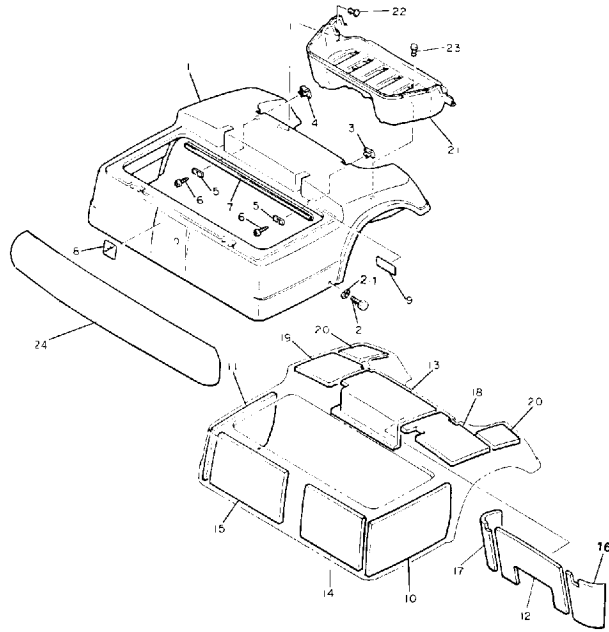

Ref. No.	Part Number	Description	Qty	Remarks
1	JF2-K8142-01-00	PANEL, REAR BODY	1	
2	90110-06078-00	BOLT, HEXAGON SOCKET ...	2	
3	JF2-K8283-00-00	COVER, 3	1	
4	JF2-K8284-00-00	COVER, 4	1	
5	JF2-78118-00-00	PLATE 2	2	
6	97780-60116-00	SCREW, TAPPING	2	
7	JF2-7836A-00-00	PROTECTOR 2	1	
8	JF2-77741-00-00	INDICATOR 1	1	
9	JF2-77764-00-00	LABEL, WARNING 4	1	
10	JF2-K8251-00-00	PAD, SILENCER 1	1	
11	JF2-K8252-00-00	PAD, SILENCER 2	1	
12	JF2-K8254-10-00	PAD, SILENCER 4	1	
13	JF2-K8255-00-00	PAD, SILENCER 5	1	
14	JF2-K8256-00-00	PAD, SILENCER 6	1	
15	JF2-K8257-00-00	PAD, SILENCER 7	1	
16	JF2-K8258-10-00	PAD, SILENCER 8	1	
17	JF2-K8259-10-00	PAD, SILENCER 9	1	
18	JF2-K825A-00-00	PAD, SILENCER 0	1	
19	JF2-K825E-00-00	PAD, SILENCER 1	1	
20	JF2-K825L-00-00	PAD, SILENCER 7	2	
21	JF2-K8237-00-00	COVER, REAR FLOOR	1	
22	90269-08069-00	RIVET	7	
23	90267-63047-00	RIVET, BLIND	2	
24	G8A-PARTS-BO-AR	ASSEMBLY, HARDWARE (G8-A)	8	OPTIONAL PART
	JF2-K814N-00-00	PLATE, ORNAMENT	1	
	PNT-90000-K0-91	PAINT	8	PALE ALMONDOPTIONAL PART
2-1	90183-06028-00	NUT, SPRING	2	

BODY FITTING

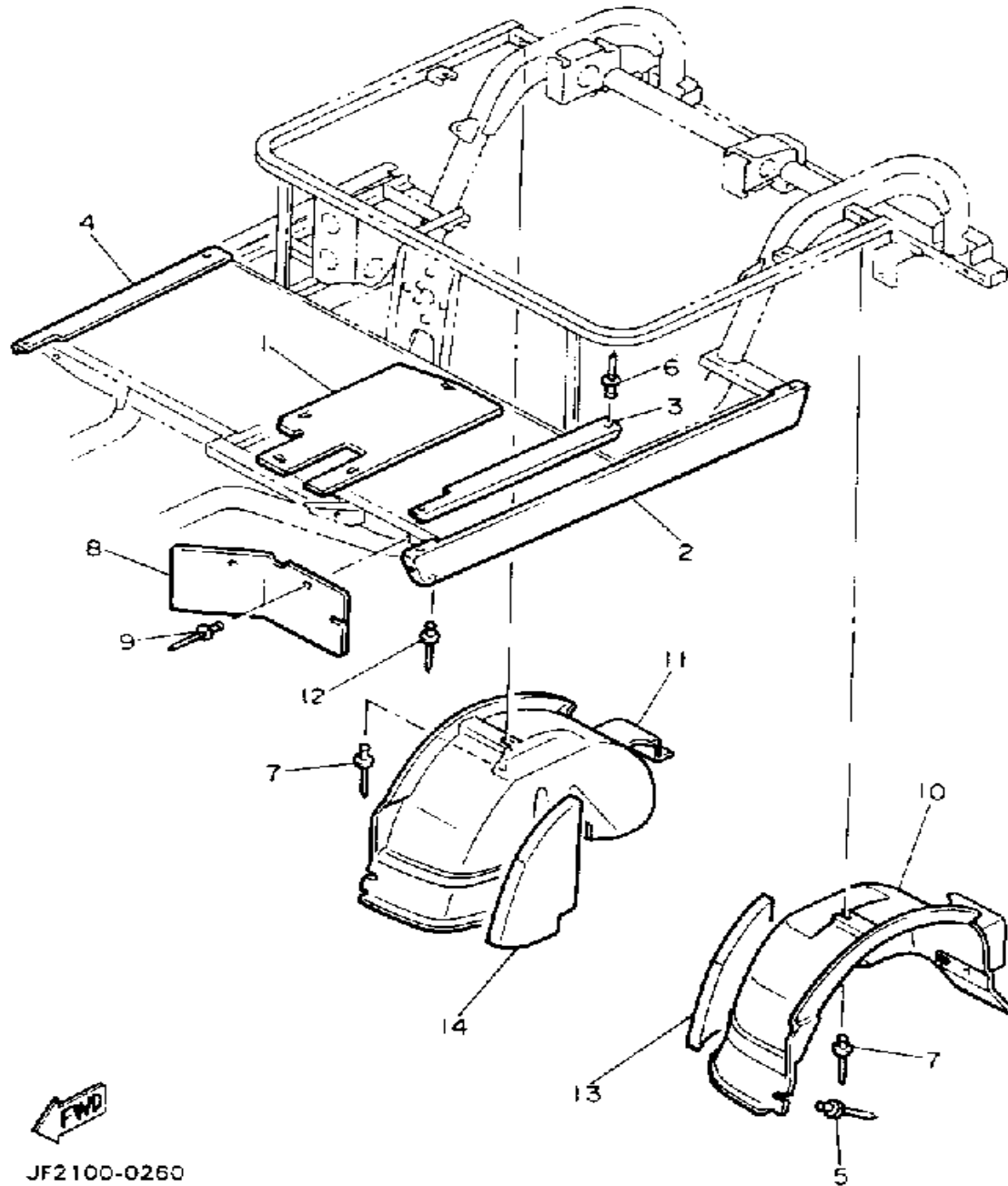

JF2100-0260

Ref. No.	Part Number	Description	Qty	Remarks
1	JF2-K8271-00-00	SERVICE LID, PEDAL	1	
2	JF2-K818A-00-00	PROTECTOR, SIDE	2	
3	JF2-K8215-00-00	PLATE, SIDE TRIM	1	
4	JF2-K821F-00-00	PLATE, SIDE TRIM	1	
5	90267-48086-00	RIVET, BLIND	4	
6	90267-48154-00	RIVET, BLIND	6	
7	90267-48086-00	RIVET, BLIND	6	
8	JF2-K8187-00-00	FLAP, FRONT FENDER (L.H)	2	
9	90267-48101-00	RIVET, BLIND	4	
10	JF2-K8191-00-00	PANEL, REAR FENDER	1	
11	JF2-K8192-00-00	PANEL, REAR FENDER	1	
12	90267-48101-00	RIVET, BLIND	6	
13	JF2-K825F-00-00	PAD, SILENCER 2	1	
14	JF2-K825G-00-00	PAD, SILENCER 3	1	

CARREIR

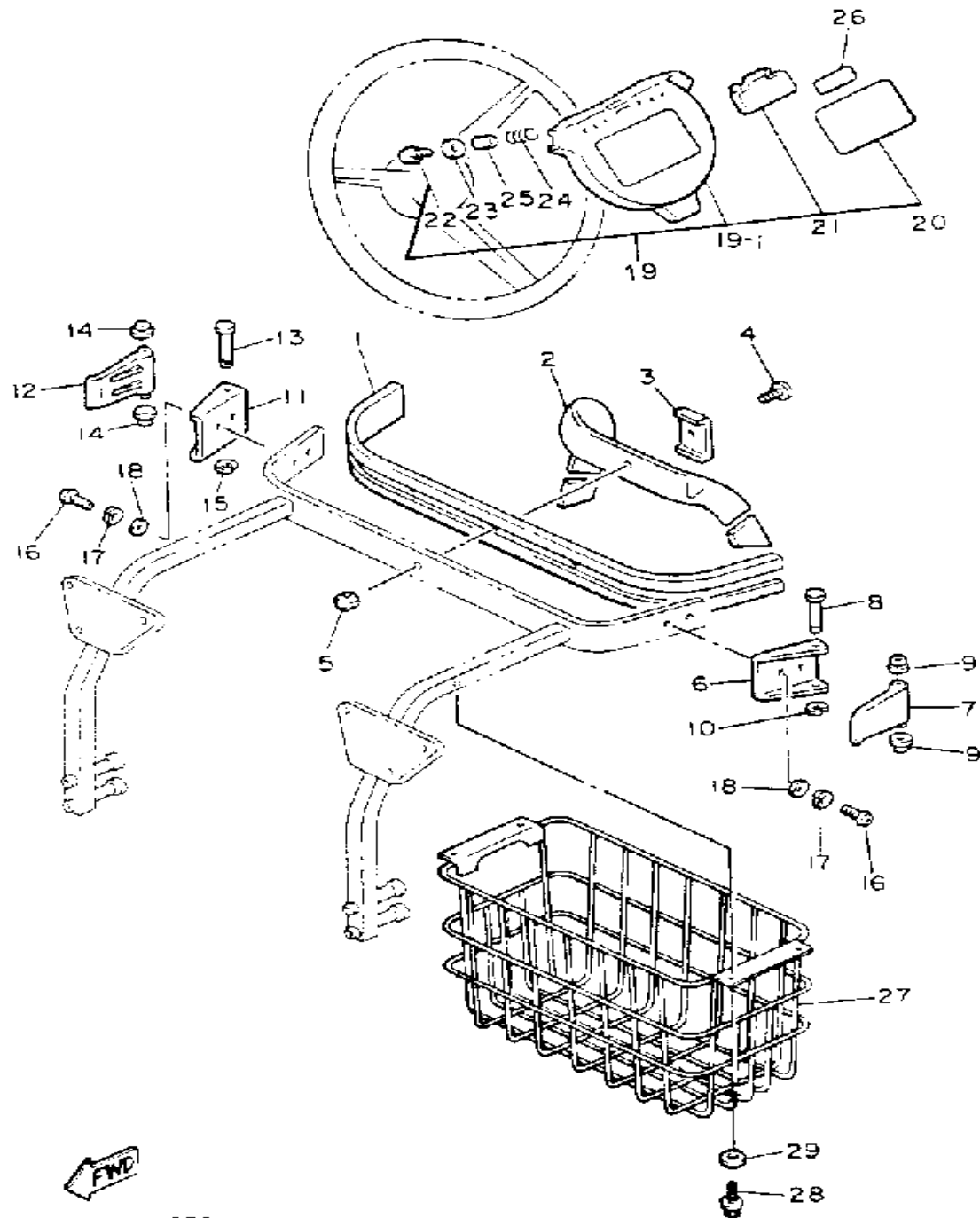

Ref. No.	Part Number	Description	Qty	Remarks
1	JF2-K8356-00-00	PAD, BAG SUPPORT	1	
2	JF2-K8355-00-00	BAND	1	
3	J38-78367-00-00	PLATE, ANCHOR	1	
4	98980-06016-00	SCREW, BINDING	1	
5	95380-06800-00	NUT	1	
6	J17-78157-01-00	BASE, LOCK	1	
7	J17-78368-01-00	LEVER, LOCK	1	
8	J17-78369-00-00	PIN, LEVER	1	
9	90386-06108-00	BUSH	2	
10	99080-05600-00	CIRCLIP	1	
11	J17-78157-01-00	BASE, LOCK	1	
12	J17-78368-01-00	LEVER, LOCK	1	
13	J17-78369-00-00	PIN, LEVER	1	
14	90386-06108-00	BUSH	2	
15	99080-05600-00	CIRCLIP	1	
16	98580-06010-00	SCREW, PAN HEAD (92503-06010)	4	
17	92995-06100-00	WASHER, SPRING	4	
18	92990-06200-00	WASHER	4	
19	JF2-K8370-00-00	HOLDER ASSEMBLY	1	
20	J50-77762-00-00	. LABEL, WARNING 2	1	
21	J55-K8358-00-00	. HOLDER 2	1	J38-78358-01
22	97706-40525-00	. SCREW, TAPPING	2	
23	90201-044A2-00	. WASHER, PLATE	2	
24	90502-10013-00	. SPRING, CONICAL	2	
25	90387-046N7-00	. COLLAR	2	
26	J51-77763-00-00	. LABEL, WARNING 3	1	
27	JF2-K8340-02-00	LUGGAGE RACK ASSEMBLY., REAR	1	

CONTINUED ON NEXT FRAME ►

CARREIR

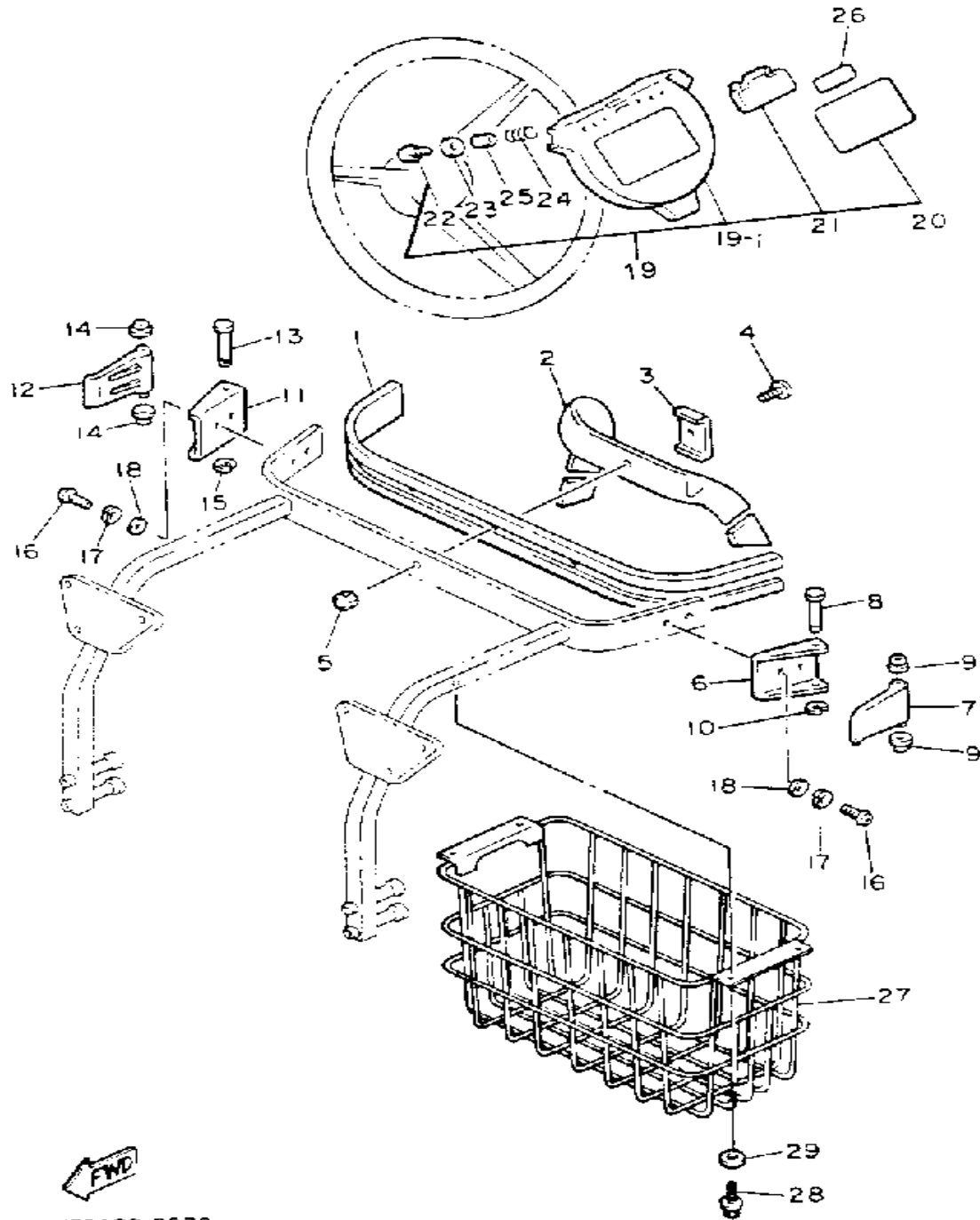

Ref. No.	Part Number	Description	Qty	Remarks
28	95805-08016-00	BOLT, FLANGE	4	
29	90201-08103-00	WASHER, PLAIN	4	
19-1	J55-K8357-00-00	. HOLDER 1	1	J38-78357-00

FWD
JF2100-D270

SEAT

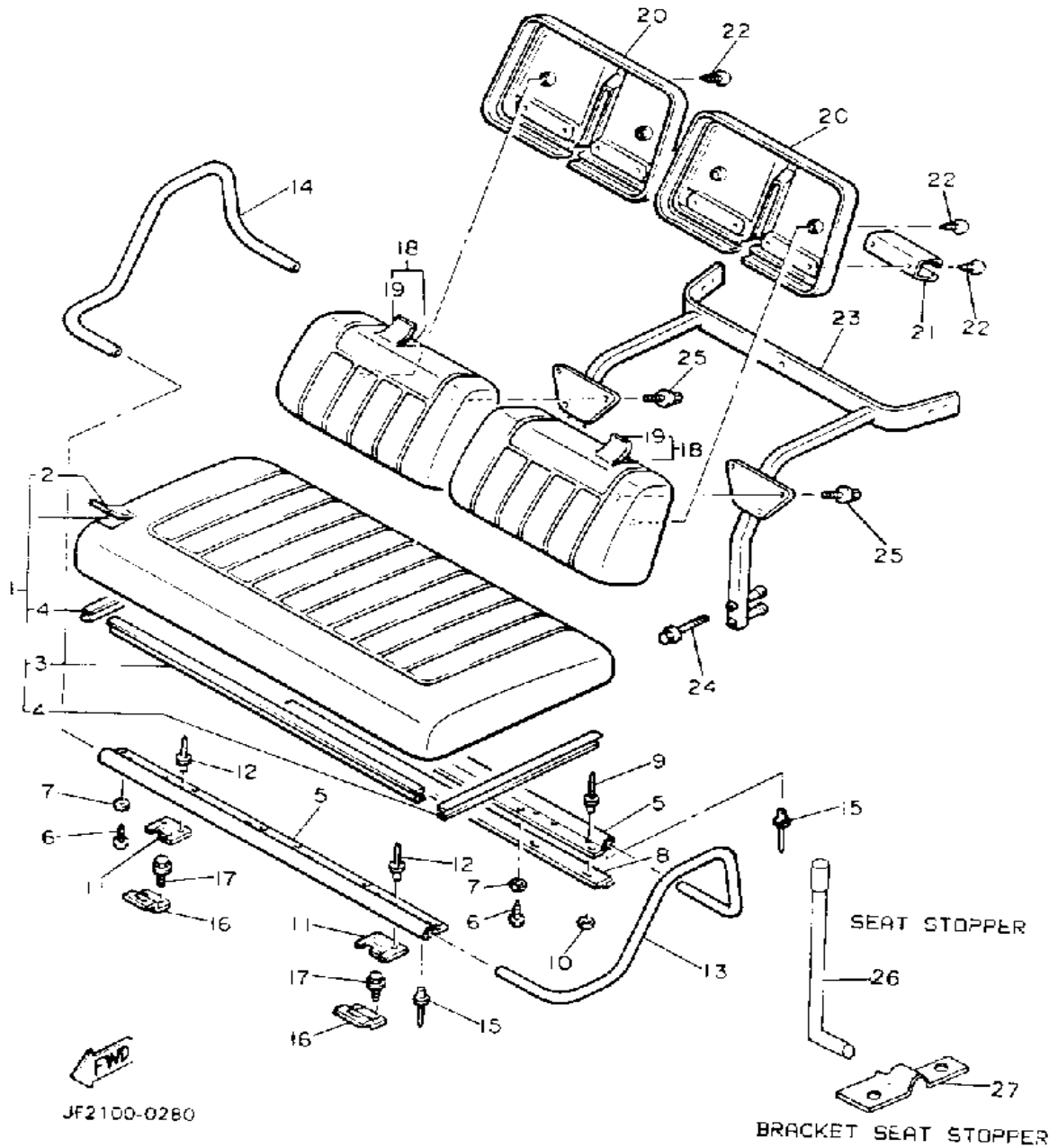

Ref. No.	Part Number	Description	Qty	Remarks
1	JF2-K8401-01-00	SEAT SUB-ASSEMBLY, CUSHION	1	
2	JF2-K8404-09-00	. COVER, SEAT	1	
3	JF2-K8425-01-00	. SEAL, SEAT	1	
4	JF2-K842A-01-00	. SEAL, SEAT 2	2	
5	JF2-K8121-01-00	REINFORCEMENT 1	2	
6	97780-60125-00	SCREW, TAPPING	12	
7	90201-06M02-00	WASHER, PLATE	12	
8	JF2-K842E-01-00	SEAL, SEAT 3	1	
9	90267-48086-00	RIVET, BLIND	6	
10	90201-04325-00	WASHER, PLATE	6	
11	JF2-K8426-00-00	HINGE, SEAT 1	2	
12	90267-48084-00	RIVET, BLIND	4	
13	JF2-K8361-01-00	ARM REST 1	1	
14	G8A-PARTS-BO-AR	ASSEMBLY, HARDWARE (G8-A)	8	
	JF2-K8362-01-00	ARM REST 2	1	
15	90267-48084-00	RIVET, BLIND	8	
16	JF2-K8427-00-00	HINGE, SEAT FEMALE	2	
17	95805-06020-00	BOLT, FLANGE	4	
18	JF2-K8402-01-00	SEAT SUB ASSEMBLY, BACK	2	
19	JF2-K841G-09-00	. COVER, SEAT BACK 2	1	
20	JF2-K8413-00-00	COVER, SEAT BACK	2	
21	J55-K835A-00-00	HOLDER, BALL	2	J38-7835A-01
22	97780-60325-00	SCREW, TAPPING	12	
23	JF2-K8423-03-00	SUPPORT, SEAT BACK	1	
24	95815-08075-00	BOLT, FLANGE	4	
25	95805-06020-00	BOLT, FLANGE	6	
26	JF2-K8421-00-00	SUPPORT, SEAT	1	

CONTINUED ON NEXT FRAME ►

SEAT

Ref. No.	Part Number	Description	Qty	Remarks
27	JF2-K8422-00-00	BRACKET, SEAT SUPPORT	1	

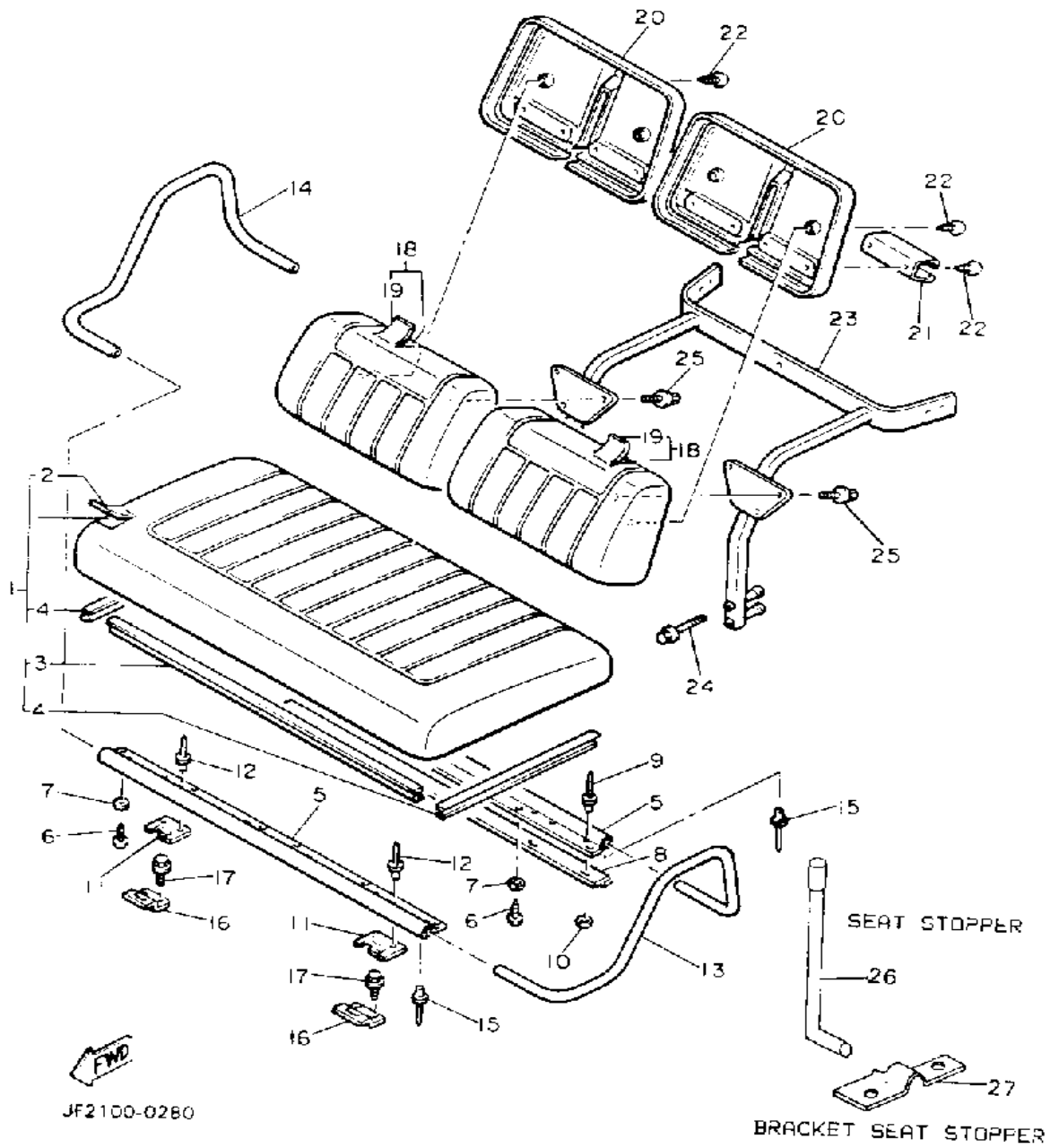

STARTING MOTOR

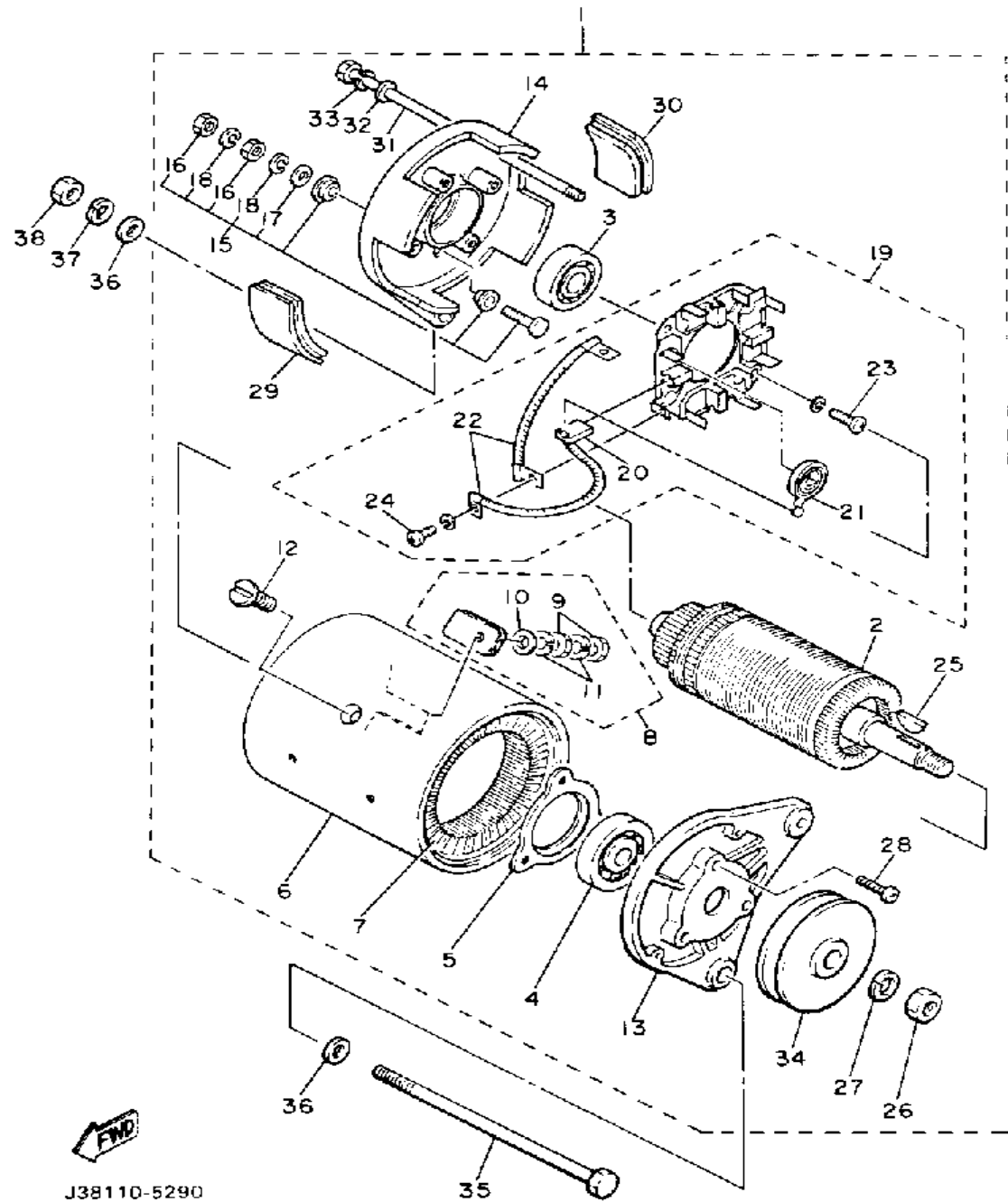

J38110-5290

Ref. No.	Part Number	Description	Qty	Remarks
1	J38-81100-11-00	STARTER GENERATOR ASSEMBLY (JF2-H1100-00-00)	1	
2	J10-81150-10-00	. ARMATURE ASSEMBLY	1	
3	J10-81157-10-00	. BEARING 1 (6202 SD)	1	
4	J10-81158-10-00	. BEARING 2 (6203 SD)	1	
5	J10-81159-10-00	. HOLDER, BEARING	1	
6	J38-81110-10-00	. STATOR ASSEMBLY	1	
7	J38-81160-10-00	. FIELD COIL ASSEMBLY	1	
8	J10-81148-10-00	. SCREW	2	
9	95380-06600-00	.. NUT	4	
10	92990-06600-00	.. WASHER, PLATE	2	
11	92995-06100-00	.. WASHER, SPRING	4	
12	J10-81146-10-00	. SCREW	4	
13	J38-81165-10-00	. BRACKET, STARTER GENERATOR	1	
14	J10-81166-10-00	. BRACKET, STARTER GENERATOR	1	
15	J10-81147-10-00	. SCREW	2	
16	95380-06600-00	.. NUT	4	
17	92990-06600-00	.. WASHER, PLATE	2	
18	92995-06100-00	.. WASHER, SPRING	4	
19	JF2-81119-00-00	. BRUSH HOLDER ASSEMBLY	1	
20	JF2-81111-00-00	.. BRUSH	4	
21	J38-81113-10-00	.. SPRING, BRUSH	4	
22	J10-81115-10-00	.. WIRE, LEAD	2	
23	98580-05016-00	.. SCREW, PAN HEAD	2	
24	98580-04010-00	.. SCREW, PAN HEAD	4	
25	J38-81163-10-00	. KEY	1	
26	95312-14600-00	. NUT	1	
27	92901-14100-00	. WASHER, SPRING	1	

CONTINUED ON NEXT FRAME ►

STARTING MOTOR

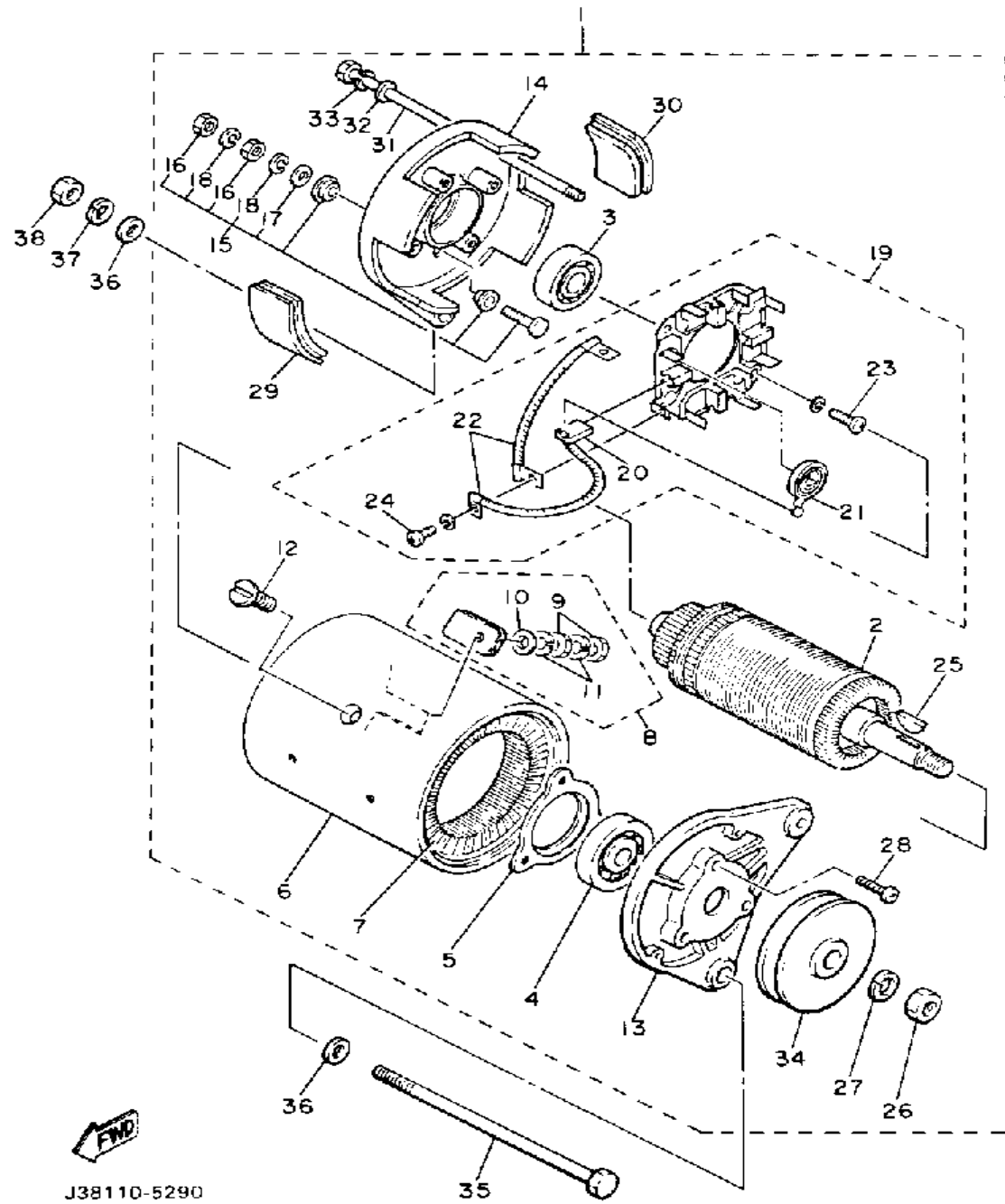

Ref. No.	Part Number	Description	Qty	Remarks
28	98501-05018-00	. SCREW, PAN HEAD	3	
29	J10-81129-10-00	. COVER, BRUSH	3	
30	J10-81129-10-00	. COVER, BRUSH	1	
31	J10-81145-10-00	. SCREW	2	
32	92990-06600-00	. WASHER, PLATE	2	
33	92995-06100-00	. WASHER, SPRING	2	
34	J38-81161-10-00	. PULLEY	1	
35	90101-12545-00	BOLT	1	
36	92990-12600-00	WASHER, PLATE	2	
37	92901-12100-00	WASHER, SPRING	1	
38	95303-12600-00	NUT	1	

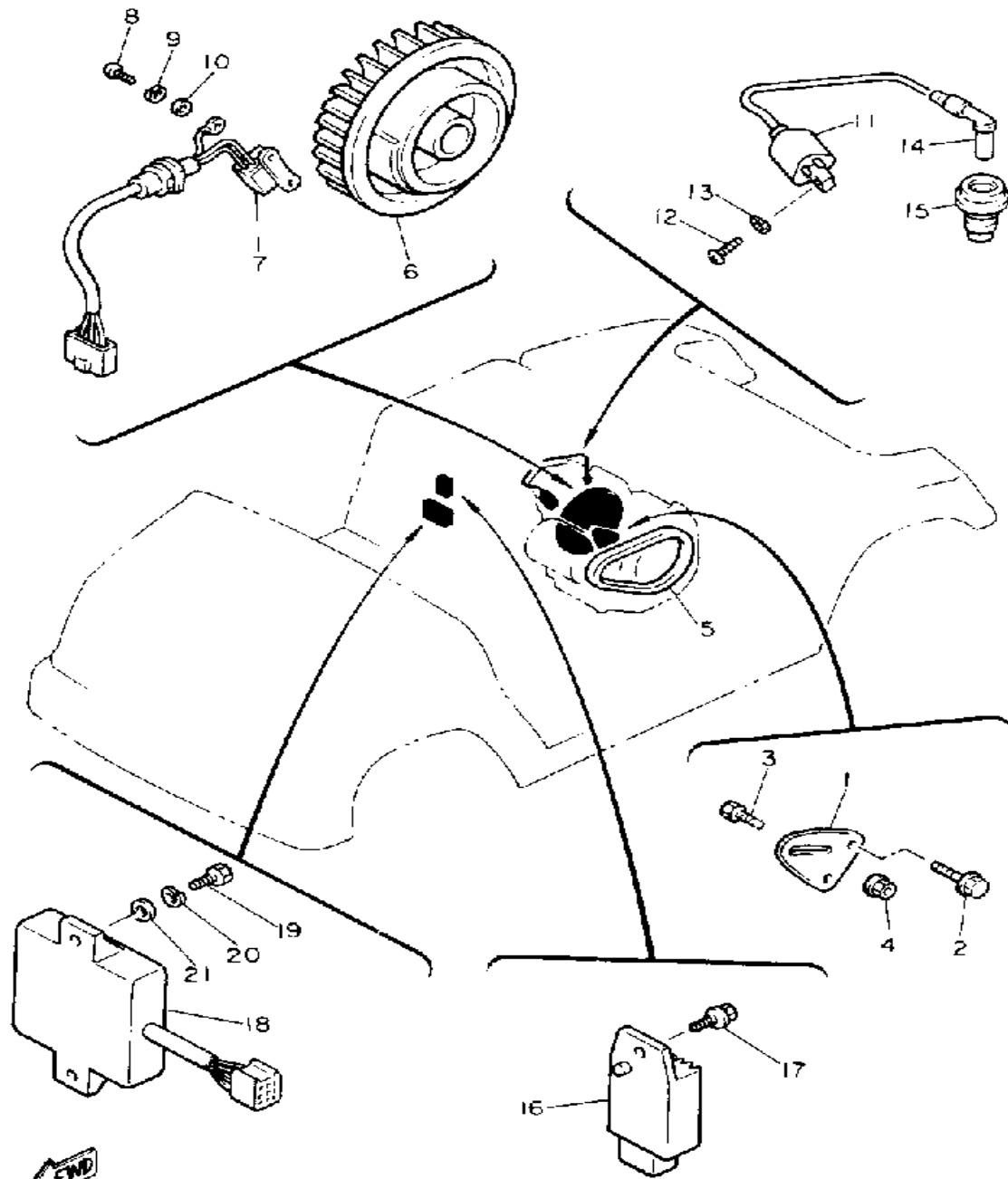

JF2100-0300

ELECTRICAL1

Ref. No.	Part Number	Description	Qty	Remarks
1	J38-81170-00-00	TENSIONER ASSEMBLY	1	
2	95821-08025-00	BOLT, FLANGE	2	
3	90109-087A5-00	BOLT	1	
4	95701-08500-00	NUT, FLANGE	1	
5	J55-H1173-00-00	BELT	1	J38-81173-00
6	JF2-81350-00-00	ROTOR ASSEMBLY	1	
7	JF2-85580-00-00	COIL, PULSER	1	
8	98580-05016-00	SCREW, PAN HEAD	2	
9	92990-05100-00	WASHER, SPRING	2	
10	92901-05600-00	WASHER, PLATE	2	
11	JF2-82310-00-00	IGNITION COIL ASSEMBLY ...	1	
12	98511-05020-00	SCREW, PAN HEAD	2	
13	92990-05100-00	WASHER, SPRING	2	
14	8K1-82370-20-00	PLUG CAP ASSEMBLY (WITH RESISTOR)	1	
15	J38-82372-00-00	SEAL, plug cap	1	
16	JF2-81910-00-00	VOLTAGE REGULATOR ASSEMBLY	1	
17	95811-06016-00	BOLT, FLANGE (95822-06016) .	1	
18	JF2-82305-00-00	IGNITOR UNIT ASSEMBLY ...	1	
19	97011-06020-00	BOLT	2	
20	92995-06100-00	WASHER, SPRING	2	
21	92990-06600-00	WASHER, PLATE	2	

ELECTRICAL 2

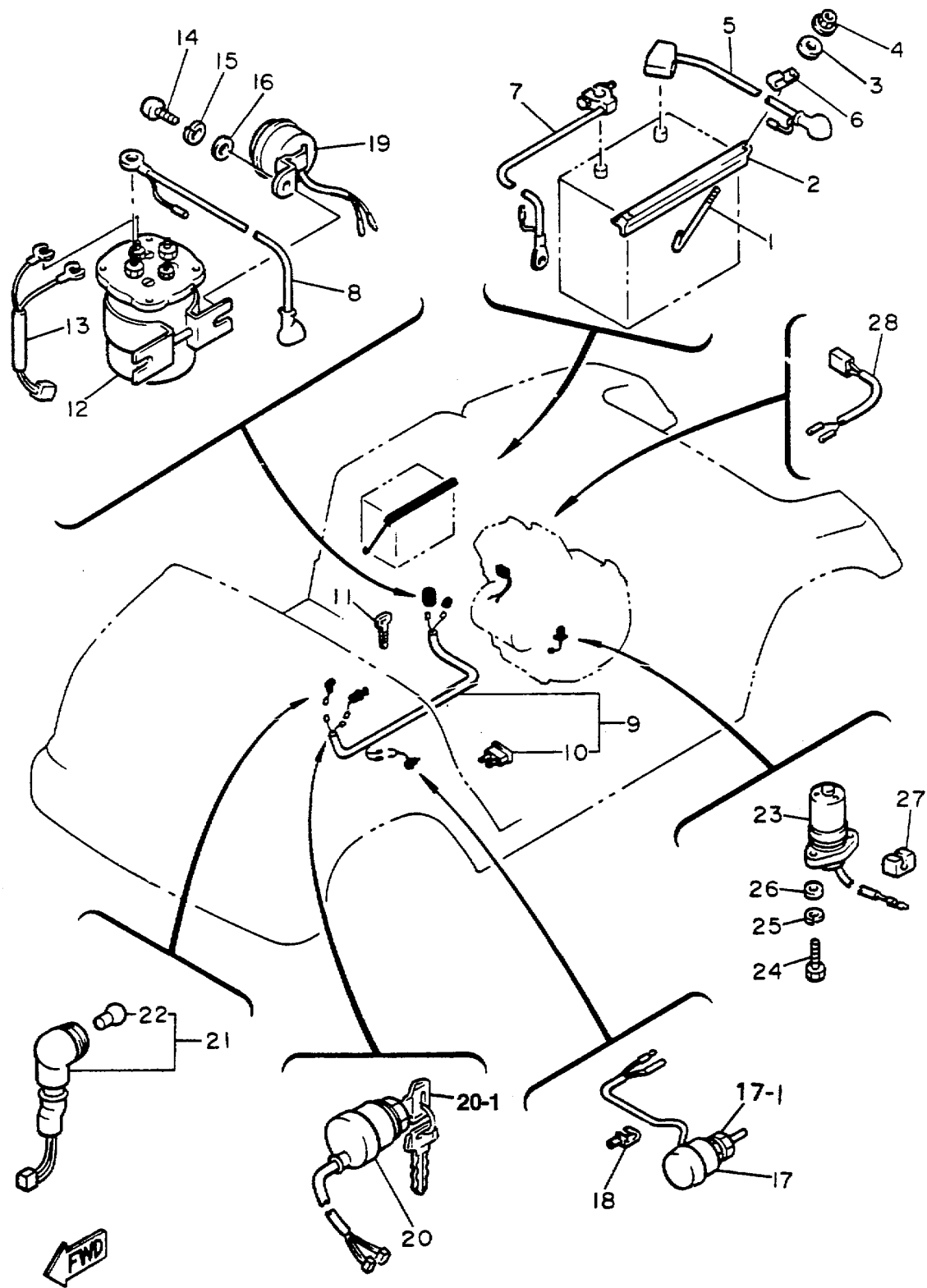

Ref. No.	Part Number	Description	Qty	Remarks
1	J17-82133-00-00	SCREW, FITTING	2	
2	J55-H2136-00-00	PLATE, BATTERY	1	J17-82136-00
3	92990-06200-00	WASHER	2	
4	95701-06500-00	NUT, FLANGE	2	
5	JF2-H2115-00-00	WIRE, PLUS LEAD	1	
6	90465-08028-00	CLAMP	1	
7	JF2-H2116-00-00	WIRE, MINUS LEAD	1	
8	JF2-H2117-00-00	WIRE, LEAD	1	
9	JF2-82590-00-00	WIRE HARNESS ASSEMBLY	1	
10	42X-82151-00-00	. FUSE (10A-BL)	2	
11	90464-23041-00	CLAMP	1	
12	JF2-H1950-00-00	RELAY ASSEMBLY.	1	
13	JF2-82105-00-00	WIRE HARNESS	1	
14	98502-06016-00	SCREW, PAN HEAD (98501-06014-00)	2	
15	92990-06100-00	WASHER, SPRING	2	
16	92990-06600-00	WASHER, PLATE	2	
17	J41-82550-00-00	STOP SWITCH ASSEMBLY	1	
18	90465-06038-00	CLAMP	1	
19	J10-83383-02-00	BUZZER	1	
20	J55-82510-00-00	MAIN SWITCH ASSEMBLY	1	
21	JF2-83530-00-00	PILOT LIGHT ASSEMBLY	1	
22	123-83516-21-00	. BULB (12V-3.4W)	1	
23	JF2-85720-00-00	OIL LEVEL GAUGE ASSEMBLY	1	
24	97011-06020-00	BOLT	2	
25	92990-06100-00	WASHER, SPRING	2	
26	92990-06600-00	WASHER, PLATE	2	
27	J38-82598-00-00	GROMMET	1	
28	G8A-PARTS-BO-AR	ASSEMBLY, HARDWARE (G8-A)	8	OPTIONAL PART

CONTINUED ON NEXT FRAME ➤

ELECTRICAL 2

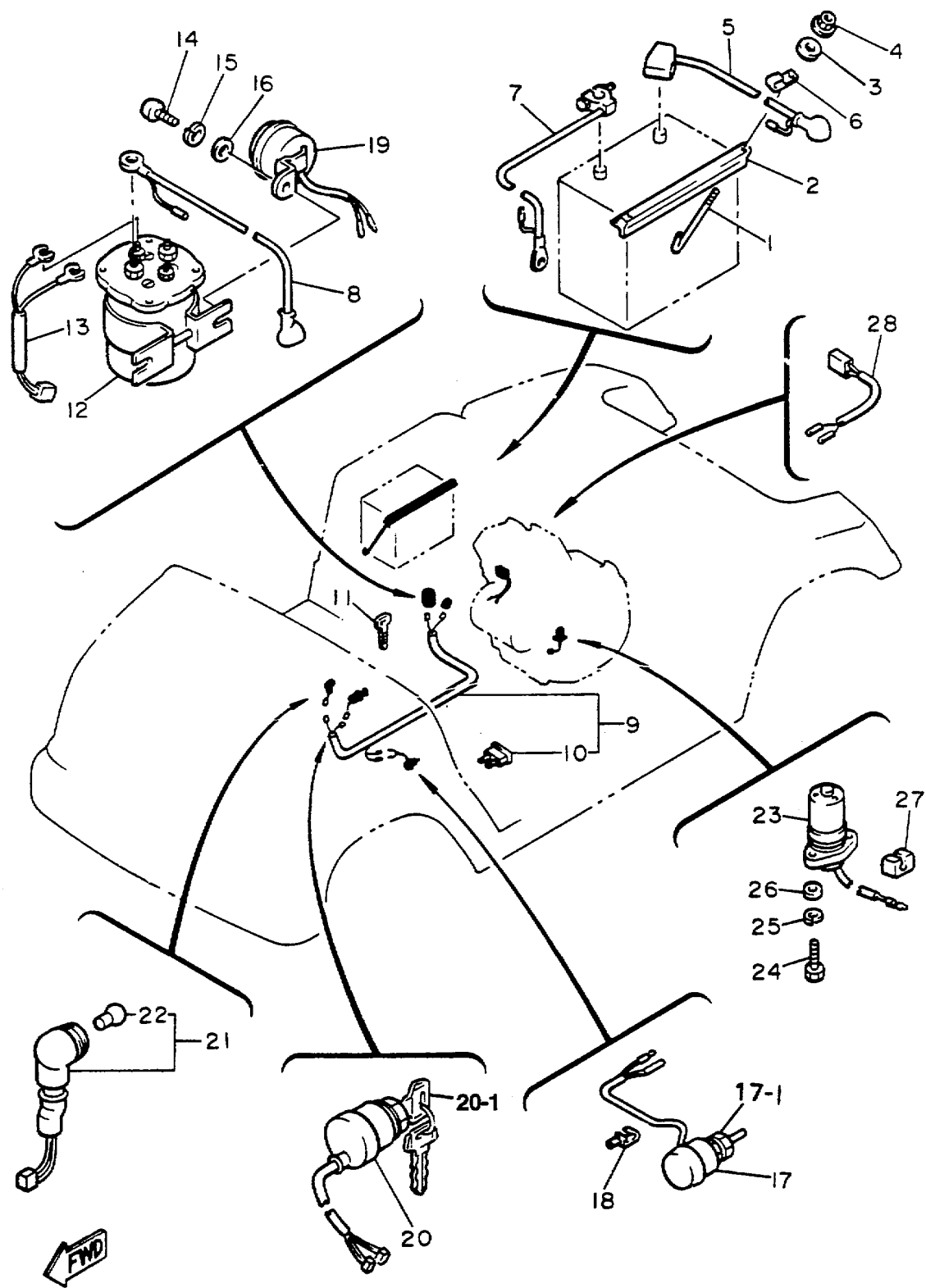

Ref. No.	Part Number	Description	Qty	Remarks
28	JF2-82318-00-00	WIRE, SUB-LEAD	1	
5-1	90108-06420-00	. BOLT, BATTERY CABLE	1	
5-2	92801-06000-00	. NUT, BATTERY CABLE	1	
7-1	90108-06420-00	. BOLT, BATTERY CABLE	1	
7-2	92801-06000-00	. NUT, BATTERY CABLE	1	
17-1	JF2-82532-00-00	. CAP, RUBBER	1	
20-1	J17-82511-20-00	. KEY, MAIN SWITCH	1	