

YAMAHA

PARTS CATALOGUE MODEL YEAR 1987

G2-AB (J38)

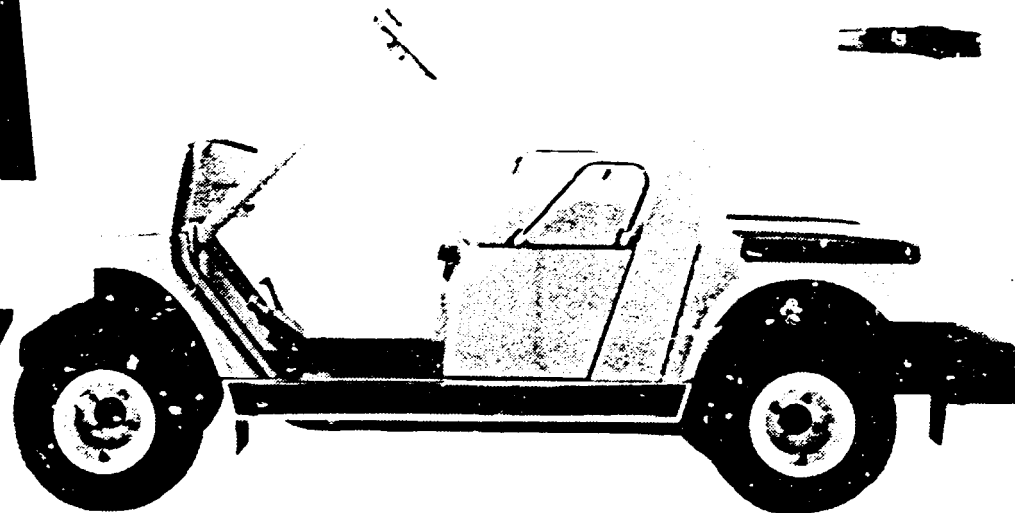

Initial Serial No.

<input type="checkbox"/>	(A) Frame Serial No.	J38-020101 and following
	(B) Engine Serial No.	J38-020101 and following

PUBLICATION	PART NUMBER	REMARKS
OWNER'S MANUAL	LIT-11623-05-88	
SERVICE MANUAL	LIT-11616-G9-00	
COUNTRY CLUB PARTS LIST	LIT-1001J-41-85	
ASSEMBLY MANUAL	N/A	

A
A
E
E
E
E
C
C
C
C
E
E
E
F
F
F
C
L
P
P
R
R
S
S
S

CYLINDER HEAD - CYLINDER

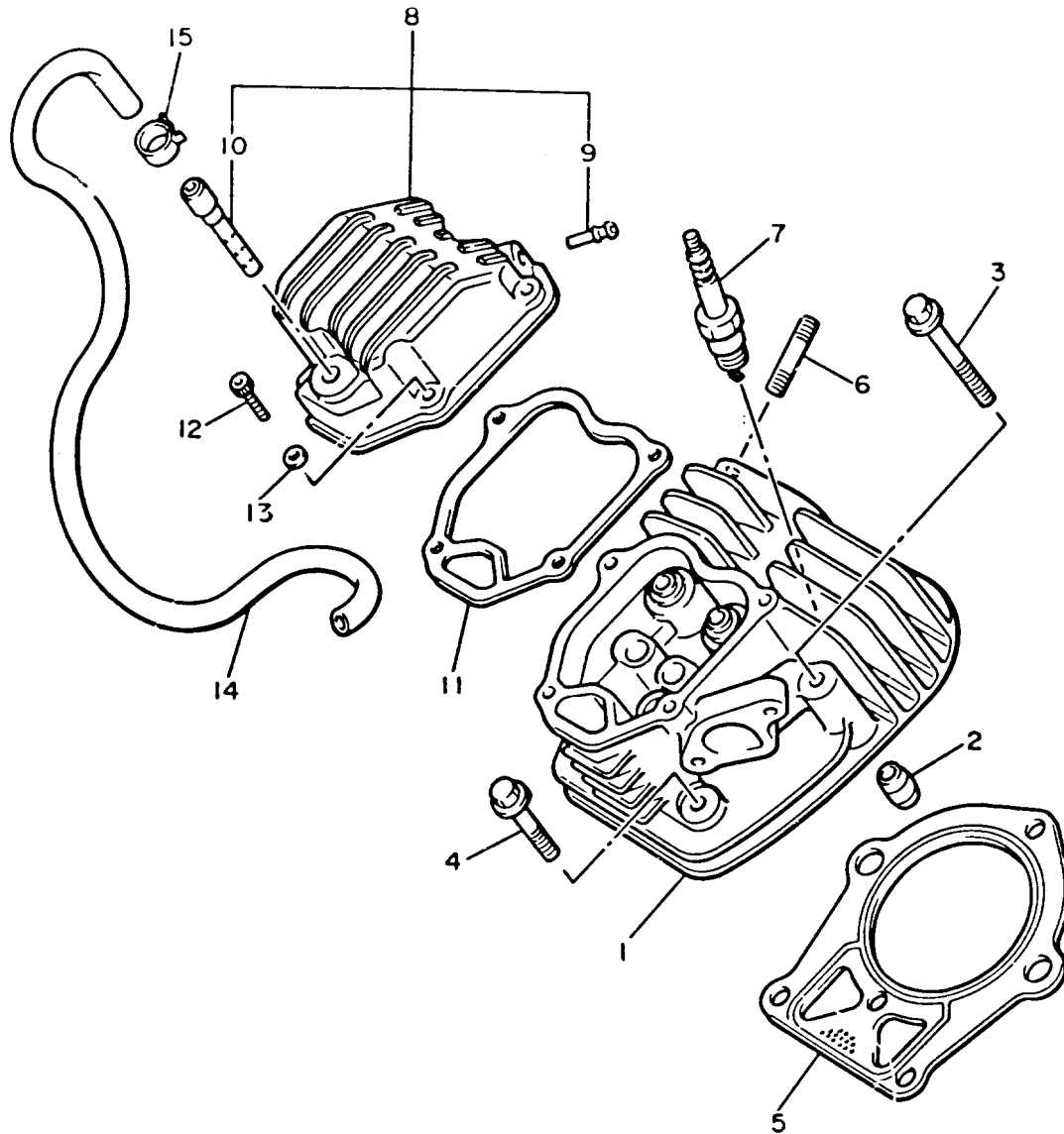

Ref. No.	Part Number	Description	Qty	Remarks
1	J38-11102-00-00	CYLINDER HEAD ASSEMBLY .	1	
2	99510-12016-00	PIN, DOWEL	2	
3	95811-08070-00	BOLT, FLANGE	3	
4	95811-08045-00	BOLT, FLANGE (JN5)	3	
5	J38-11181-00-00	GASKET, CYLINDER HEAD 1 .	1	
6	95612-08618-00	BOLT, STUD	2	
7	NGK-B5ES0-00-00	PLUG, SPARK (NGK B5ES) ...	1	
8	J38-11191-00-00	COVER, CYLINDER HEAD 1 ..	1	
9	J38-11116-00-00	. JOINT, BREATHER	2	
10	J38-24461-00-00	. PIPE, JOINT	1	
11	J38-11193-00-00	GASKET, head cover 1	1	
12	91316-06025-00	BOLT	4	
13	92990-06600-00	WASHER, PLATE	4	
14	90445-130F8-00	HOSE	1	
15	90467-12052-00	CLIP	2	



J38110-5010

CRANKSHAFT - PISTON

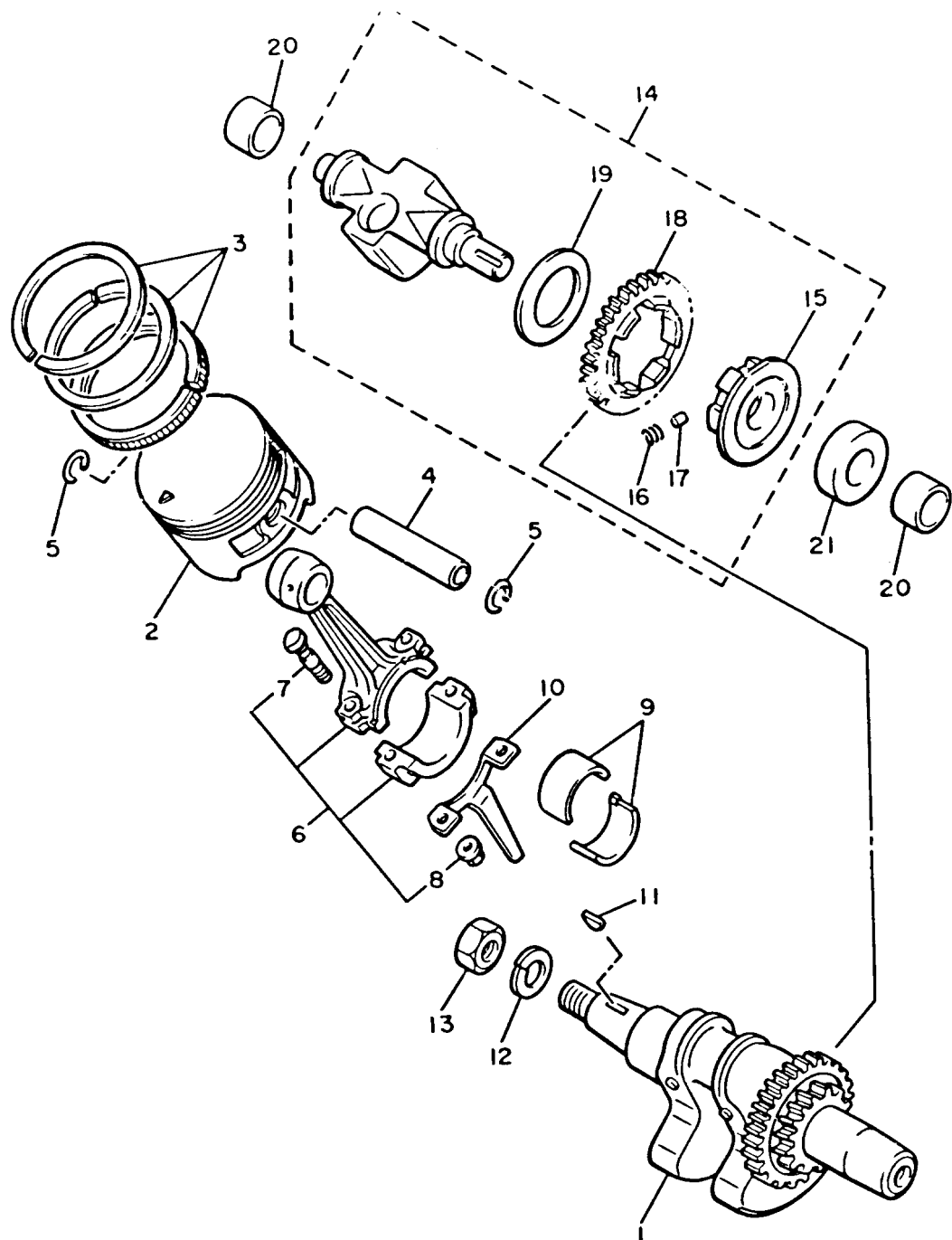

Ref. No.	Part Number	Description	Qty	Remarks
1	J38-11400-00-00	CRANKSHAFT ASSEMBLY	1	
2	7A9-11633-00-00	. PIN, PISTON	1	
	93450-19047-00	. CIRCLIP	2	
	99999-01891-00	PISTON (STD) (J38-11631-00-A0)	1	U.R. STD
	99999-01892-00	PISTON (0.25MM O/S) (J38-11635-00)	1	Alt. Part
	99999-01893-00	PISTON (0.50MM O/S) (J38-11636-00)	1	Alt. Part
	J38-11631-01-A0	. PISTON (STD)	1	STD
	J38-11635-01-00	. PISTON (0.25MM O/S)	1	
	J38-11636-01-00	. PISTON (0.50MM O/S)	1	
3	J38-11610-00-00	PISTON RING SET (STD)	1	U.R. STD
	J38-11610-10-00	PISTON RING SET (0.25MM O/S)	1	Alt. Part
	J38-11610-20-00	PISTON RING SET (0.50MM O/S)	1	Alt. Part
4	2F1-11633-00-00	PIN, piston	1	
5	93450-19052-00	CIRCLIP	2	
6	J38-11650-00-00	CONNECTING ROD ASSEMBLY	1	
7	J38-11654-00-00	. BOLT, CONNECTING ROD	2	
8	90179-08327-00	. NUT	2	
9	J38-11656-00-00	BEARING, CON-ROD	2	U.R.
	J38-11656-10-00	BEARING, CON-ROD	2	U.R.
	J38-11656-20-00	BEARING, CON-ROD	2	U.R.
10	J38-11657-00-00	SPLASHER, OIL	1	
11	90280-16053-00	KEY, WOODRUFF	1	
12	92901-16100-00	WASHER, SPRING	1	
13	90170-16182-00	NUT	1	
14	J38-11500-00-00	BALANCER ASSEMBLY	1	

 J38100-7020

CONTINUED ON NEXT FRAME ►

CRANKSHAFT - PISTON

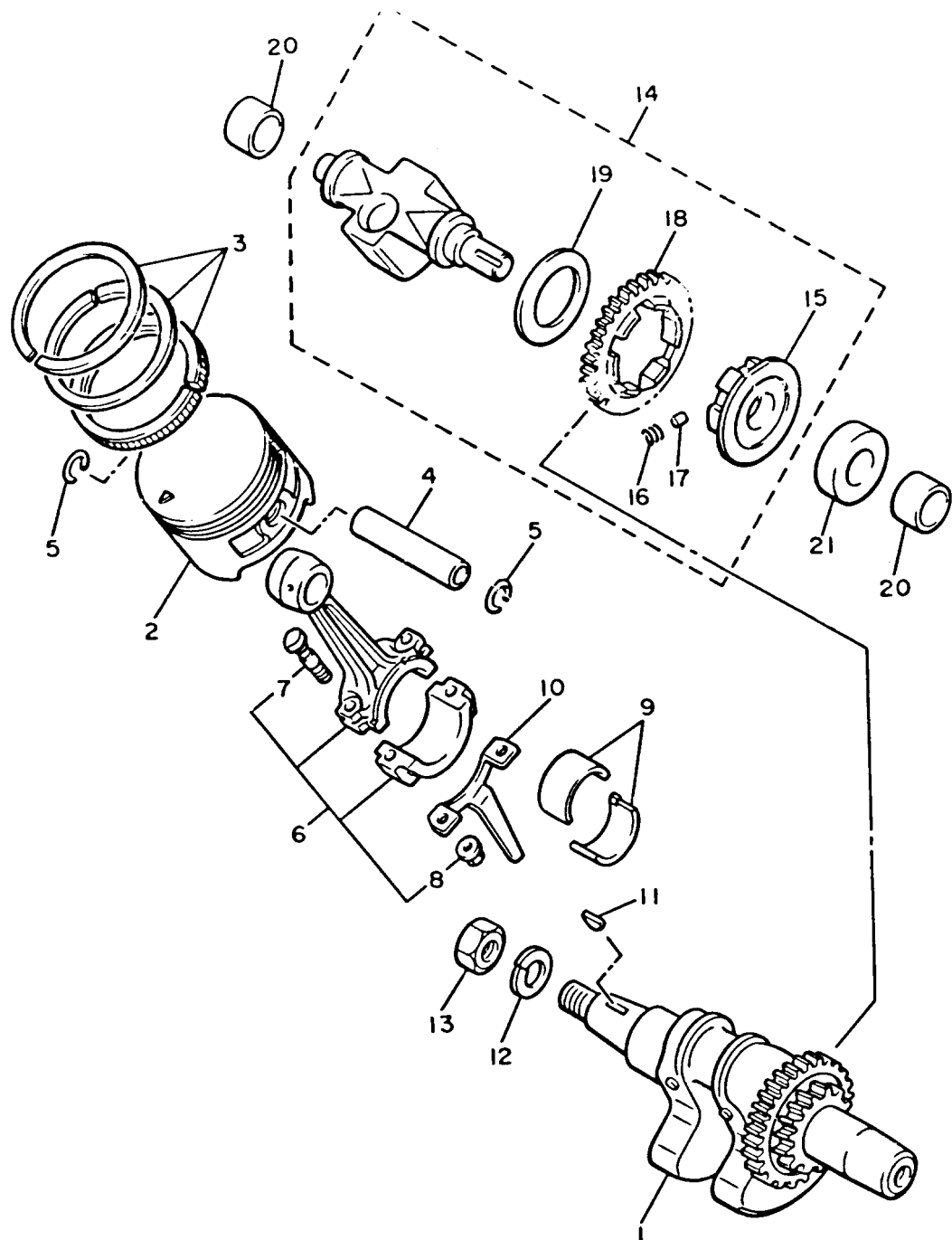

Ref. No.	Part Number	Description	Qty	Remarks
15	J38-11496-00-00	. BOSS, BUFFER	1	
16	90501-21133-00	. SPRING, COMPRESSION	6	
17	93605-10090-00	. PIN, DOWEL	3	
18	J38-11531-00-00	. GEAR, BALANCE WT	1	
19	90201-201G9-00	. WASHER, PLATE	1	
20	90387-155R3-00	COLLAR	2	
21	90387-152M7-00	COLLAR	1	



J38100-7020

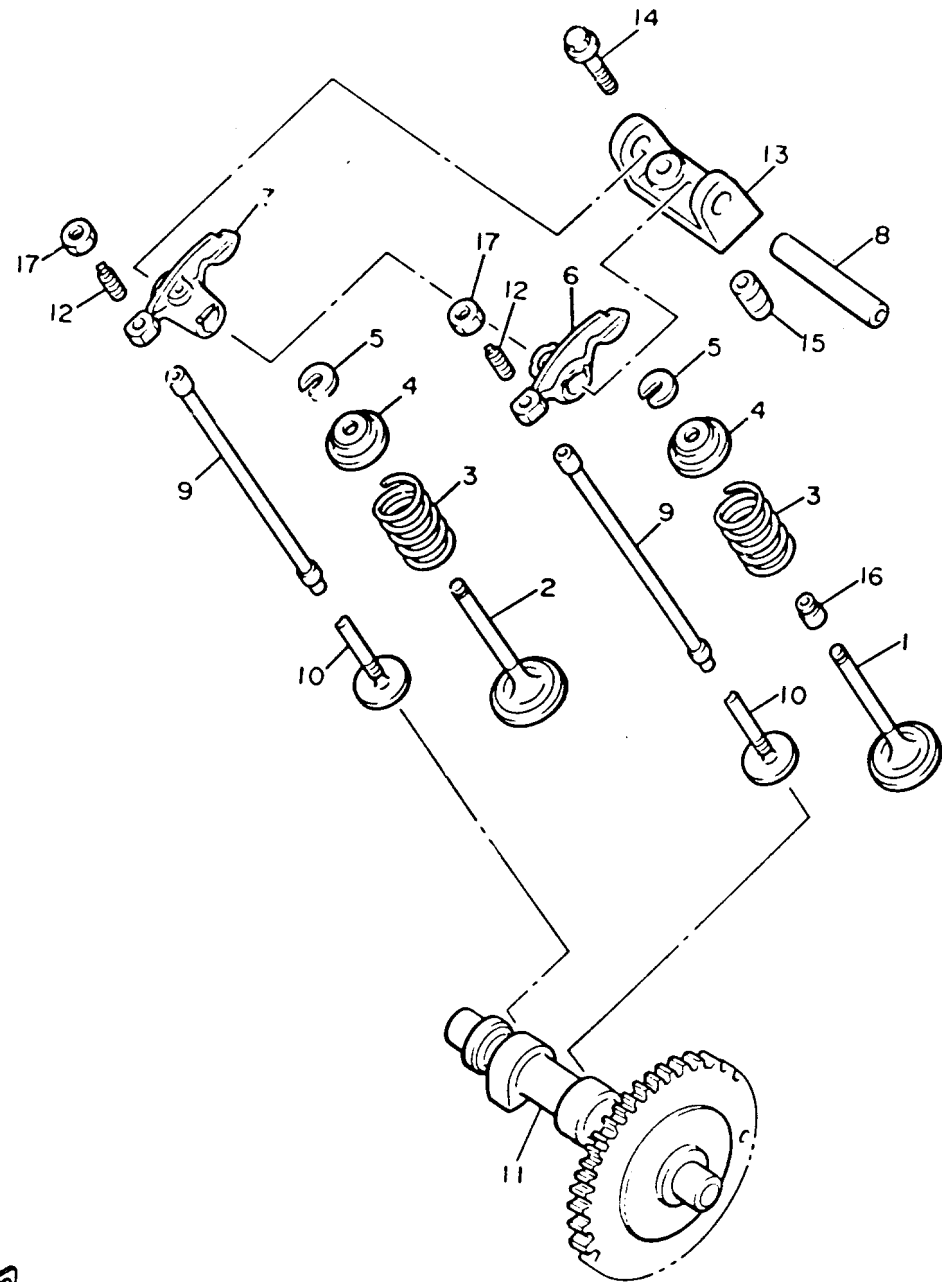

VALVE

Ref. No.	Part Number	Description	Qty	Remarks
1	99999-01846-00	VALVE, intake (J38-12111-00)	1	
	J38-12111-01-00	VALVE, INTAKE	1	
	J38-12117-01-00	RETAINER, VALVE SPRING	1	
	J38-12118-00-00	COTTER, VALVE	1	
2	99999-01847-00	VALVE, exhaust (J38-12121-00)	1	
	J38-12117-01-00	RETAINER, VALVE SPRING	1	
	J38-12118-00-00	COTTER, VALVE	1	
	J38-12121-01-00	VALVE, EXHAUST	1	
3	90501-264A9-00	SPRING, COMPRESSION	2	
4	J38-12117-00-00	RETAINER, valve spring	2	
	J38-12117-01-00	RETAINER, VALVE SPRING	2	357 ~
5	4G0-12118-00-00	COTTER, VALVE	4	
	J38-12118-00-00	COTTER, VALVE	2	357 ~
6	J38-12151-01-00	ARM, VALVE ROCKER	1	
7	J38-12161-01-00	ARM, VALVE ROCKER 2	1	
8	J38-12156-00-00	SHAFT, ROCKER 2	1	
9	J38-12154-00-00	ROD, VALVE PUSH	2	
10	J38-12153-00-00	LIFTER, VALVE	2	
11	J38-12171-00-00	CAMSHAFT 1	1	
12	J38-12159-00-00	SCREW, VALVE ADJUSTING	2	
13	J38-12152-00-00	SUPPORT, ROCKER ARM	1	
14	95811-06030-00	BOLT, FLANGE	2	
15	91810-09014-00	PIN, DOWEL	2	
16	5H0-12119-00-00	SEAL, VALVE STEM	1	
17	90170-06128-00	NUT	2	



J38100-6030

AIR SHROUD - FAN

Ref. No.	Part Number	Description	Qty	Remarks
1	J38-12621-01-00	CASE, FAN	1	
2	95811-06020-00	BOLT, FLANGE	5	
3	97780-60116-00	SCREW, TAPPING	4	
4	J38-12640-00-00	FAN CASE COVER COMP. ...	1	
5	J38-12651-01-00	AIR SHROUD, CYLINDER 1 ...	1	
6	J38-12652-00-00	AIR SHROUD, CYLINDER 2 ...	1	
7	98503-06014-00	SCREW, PAN HEAD (92502-06016)	4	
8	92990-06600-00	WASHER, PLATE	4	
9	90109-06513-00	BOLT	4	
10	J38-12631-00-00	DEFLECTOR 1	1	
11	90267-48086-00	RIVET, BLIND	2	
12	90201-04325-00	WASHER, PLATE	2	
13	90464-15093-00	CLAMP	1	

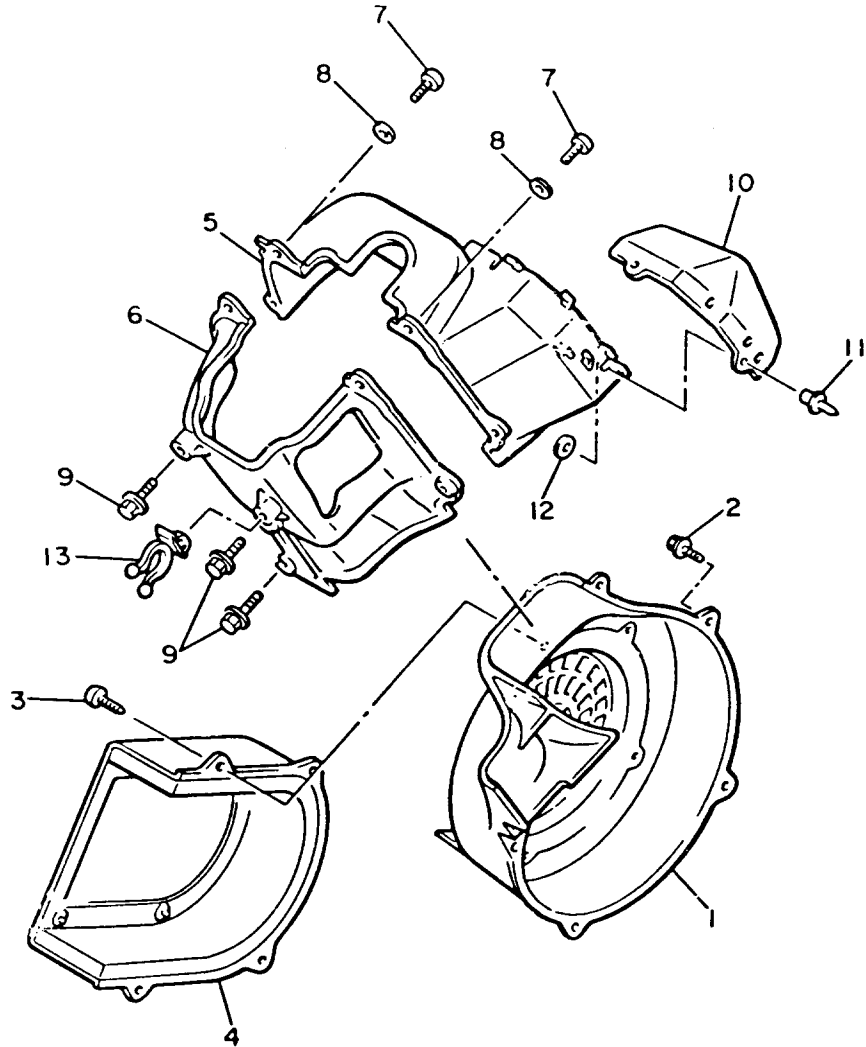

J38100-7040

AIR CLEANER

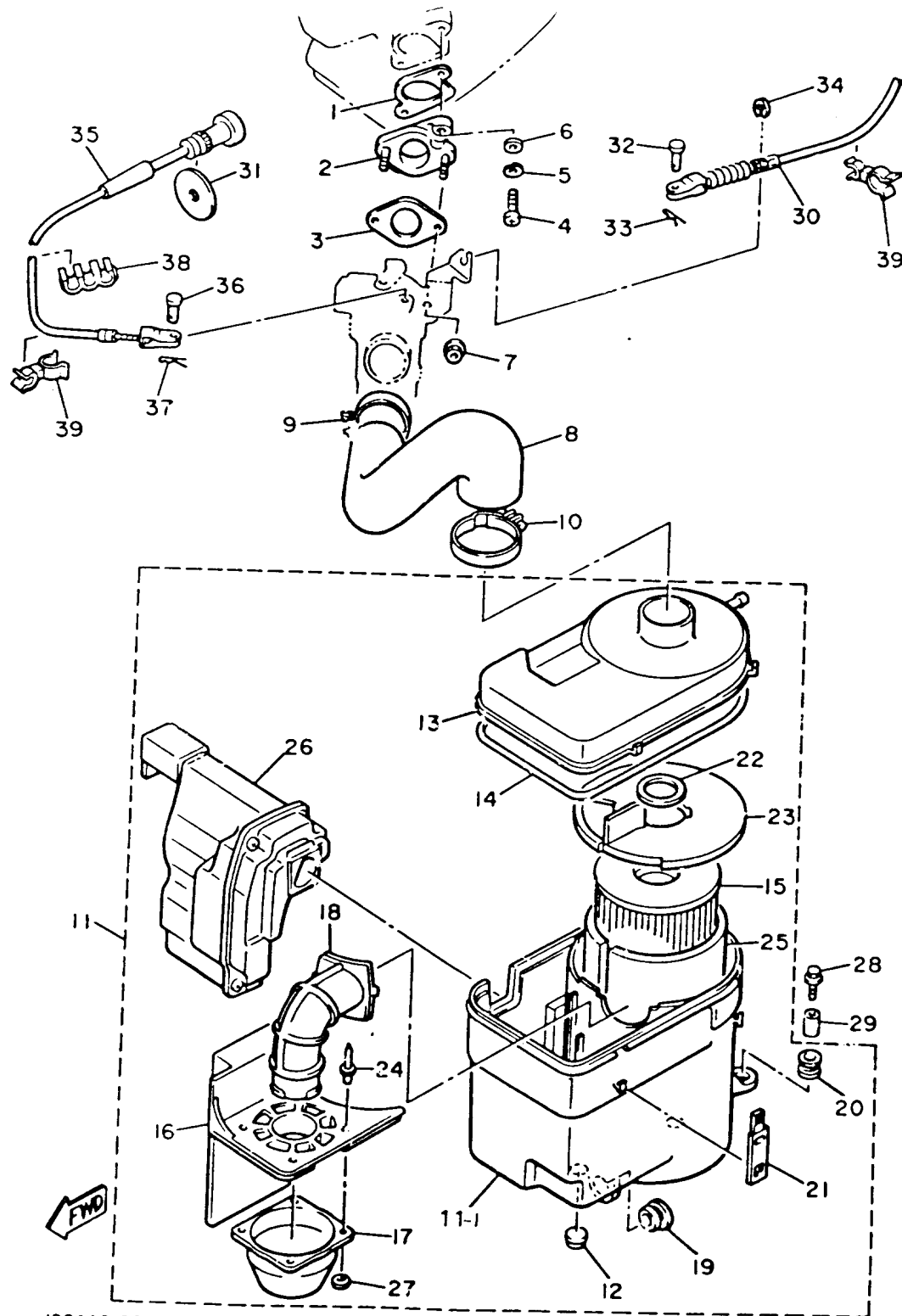

J38110-5050

Ref. No.	Part Number	Description	Qty	Remarks
1	J38-13556-00-00	GASKET, MANIFOLD	1	
2	J38-13596-00-00	JOINT, CARBURETOR 2	1	
3	J38-13557-00-00	GASKET	1	
4	98580-06030-00	SCREW PAN HEAD	2	
5	92995-06100-00	WASHER, SPRING	2	
6	92990-06600-00	WASHER, PLATE	2	
7	95601-06200-00	NUT, U FLANGE	2	
8	J38-14453-01-00	JOINT, AIR CLEANER 1	1	
9	90460-43279-00	CLAMP, HOSE	1	
10	90460-53239-00	CLAMP, HOSE	1	
11	J38-14410-01-00	AIR CLEANER ASSEMBLY 1	1	
12	90480-14100-00	. GROMMET	2	
13	J38-14412-02-00	. CAP, CLEANER CASE 1	1	
14	55K-14476-00-00	. SEAL	1	
15	J38-14450-00-00	. ELEMENT ASSEMBLY, AIR CLEANER	1	
16	J38-14484-00-00	. PLATE, CLEANER CASE FITTING	1	
17	J38-14479-00-00	. FUNNEL	1	
18	J38-14419-00-00	. PIPE	1	
19	90480-18277-00	. GROMMET	1	
20	90480-13238-00	. GROMMET	2	
21	J10-14436-00-00	. HOOK	4	
22	J38-14416-00-00	. GASKET, AIR CLEANER	1	
23	J38-1441F-00-00	. PARTN, AIR CLNR CSAIR CLEANER CASE	1	
24	90267-40073-00	. RIVET, BLIND	4	
25	J10-14417-00-00	. COVER 1	1	
26	J38-1446A-00-00	. SURGE TANK ASSEMBLY	1	
27	92990-04200-00	. WASHER, PLAIN	4	

CONTINUED ON NEXT FRAME ►

AIR CLEANER

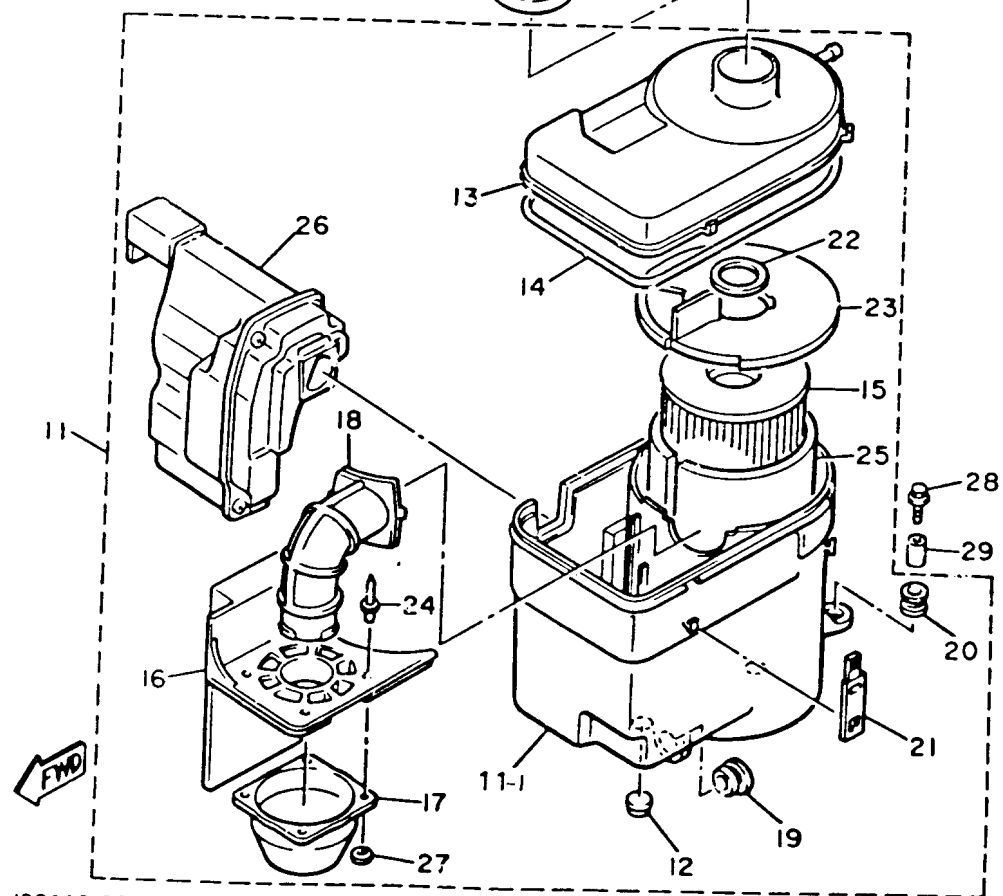
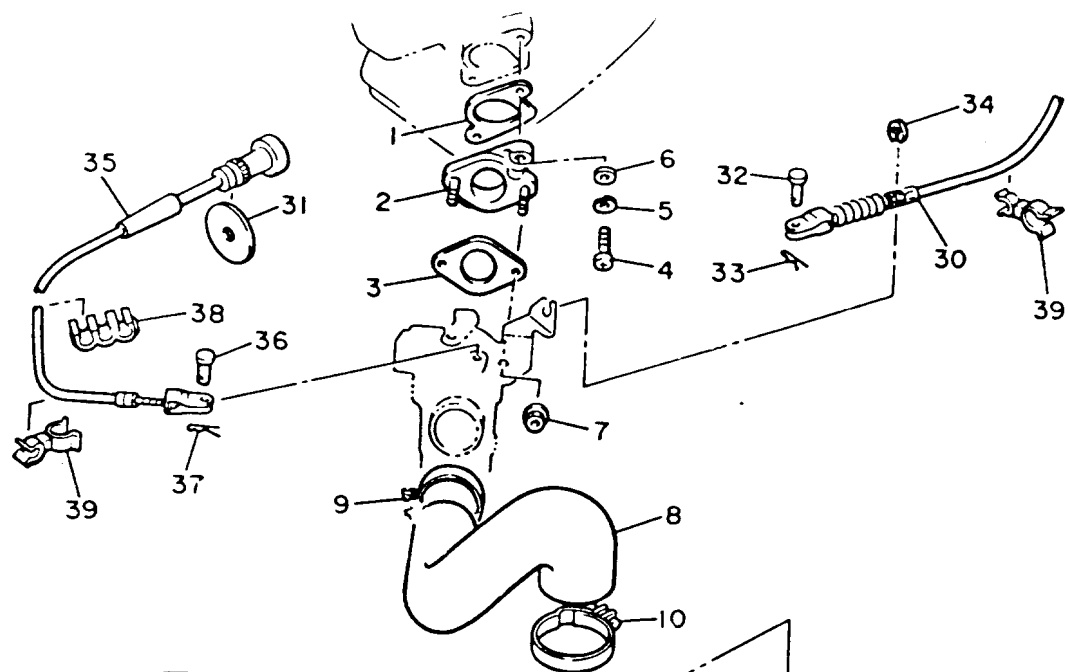

J38110-5050

Ref. No.	Part Number	Description	Qty	Remarks
28	90119-06097-00	BOLT, WITH WASHER	2	
29	90387-07390-00	COLLAR	2	
30	J38-26312-00-00	CABLE, THROTTLE 2	1	
31	90201-114E6-00	WASHER, PLATE	1	
32	91701-05010-00	PIN, CYLINDER. HEAD	2	
33	90468-10050-00	CLIP	2	
34	99080-07600-00	CIRCLIP (E)	1	
35	JF2-F6331-01-00	CABLE, STARTER 1	1	
36	91701-05010-00	PIN, CYLINDER. HEAD	1	
37	90468-10050-00	CLIP	1	
39	90464-20096-00	CLAMP (J38)	2	
11-1	J38-14411-00-00	. CASE, AIR CLEANER 1	1	

CARBURETOR

Ref. No.	Part Number	Description	Qty	Remarks
1	J38-14101-00-00	CARBURETOR ASSEMBLY 1	1	
2	98501-05010-00	. SCREW, PAN HEAD	1	
3	92990-05100-00	. WASHER, SPRING	1	
4	J38-14243-00-00	. PLATE	1	
5	75G-14211-00-00	. SCREW, PILOT ADJUSTING	1	
6	620-14212-00-00	. SPRING, PILOT ADJUSTING	2	
7	J10-14122-00-00	. SCREW, THROTTLE	1	
8	J38-14186-00-00	. PIN, FLOAT	1	
9	J38-14185-00-00	. FLOAT	1	
10	620-14142-67-00	. JET, PILOT (#67.5)	1	Alt. Part
	620-14142-72-00	. JET, PILOT (#72.5)	1	UR STD
11	J38-14133-00-00	. SPRING, THROTTLE STOP	1	
12	J38-14581-00-00	. BRACKET	1	
13	98580-06010-00	. SCREW, PAN HEAD (92503-06010)	1	
14	92995-06100-00	. WASHER, SPRING	1	
15	98701-05008-00	. SCREW, FLAT HEAD	2	
16	J38-14291-00-00	. BRACKET 1	1	
17	3G2-1423E-41-00	. JET, MAIN (#103.8)	1	Alt. Part
	3G2-1423E-42-00	. JET, MAIN (#106.3)	1	UR STD
18	796-14184-00-00	. GASKET, FLOAT CHAMBER	1	
19	127-14198-00-00	. GASKET	1	
20	7R1-14162-00-00	. BOLT, HOLDING	1	
21	J10-14597-00-00	. WASHER	1	
22	J38-14150-00-00	. NEEDLE ASSEMBLY	1	
23	J10-14131-00-00	SPRING, THROTTLE	1	
	J10-14535-00-00	BUSHING, THROTTLE SHAFT	1	
	J10-14582-00-00	ARM, CHOKE	1	
	J38-14141-00-00	. NOZZLE, MAIN	1	

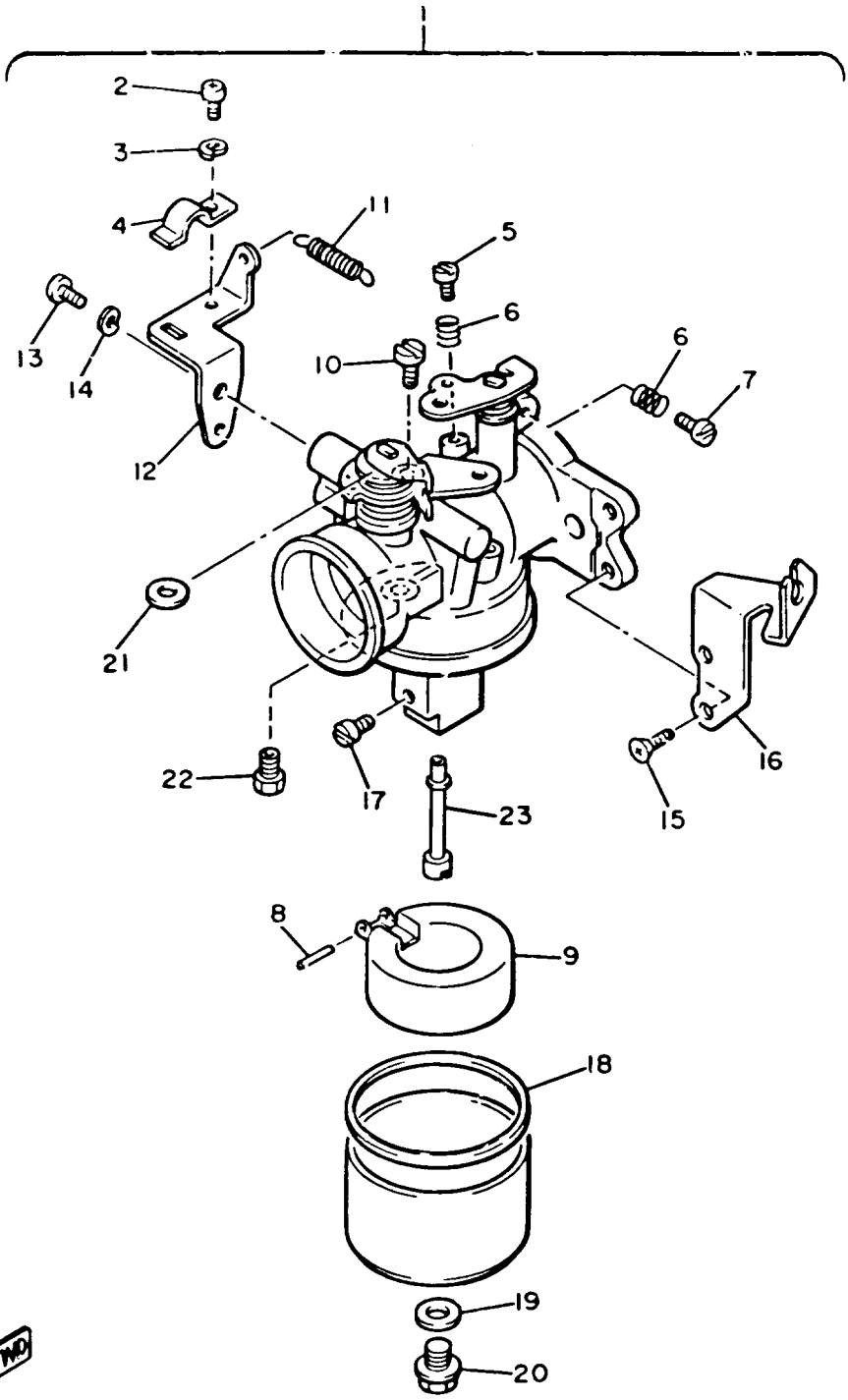

J38110-5060

CONTINUED ON NEXT FRAME ►

CARBURETOR

Ref. No.	Part Number	Description	Qty	Remarks
23	J38-14202-09-00	THROTTLE LEVER COMP 1	
	J38-14218-00-00	SPRING, LOWER CHOKE 1	
	J38-14589-00-00	SPRING, UPPER CHOKE 1	

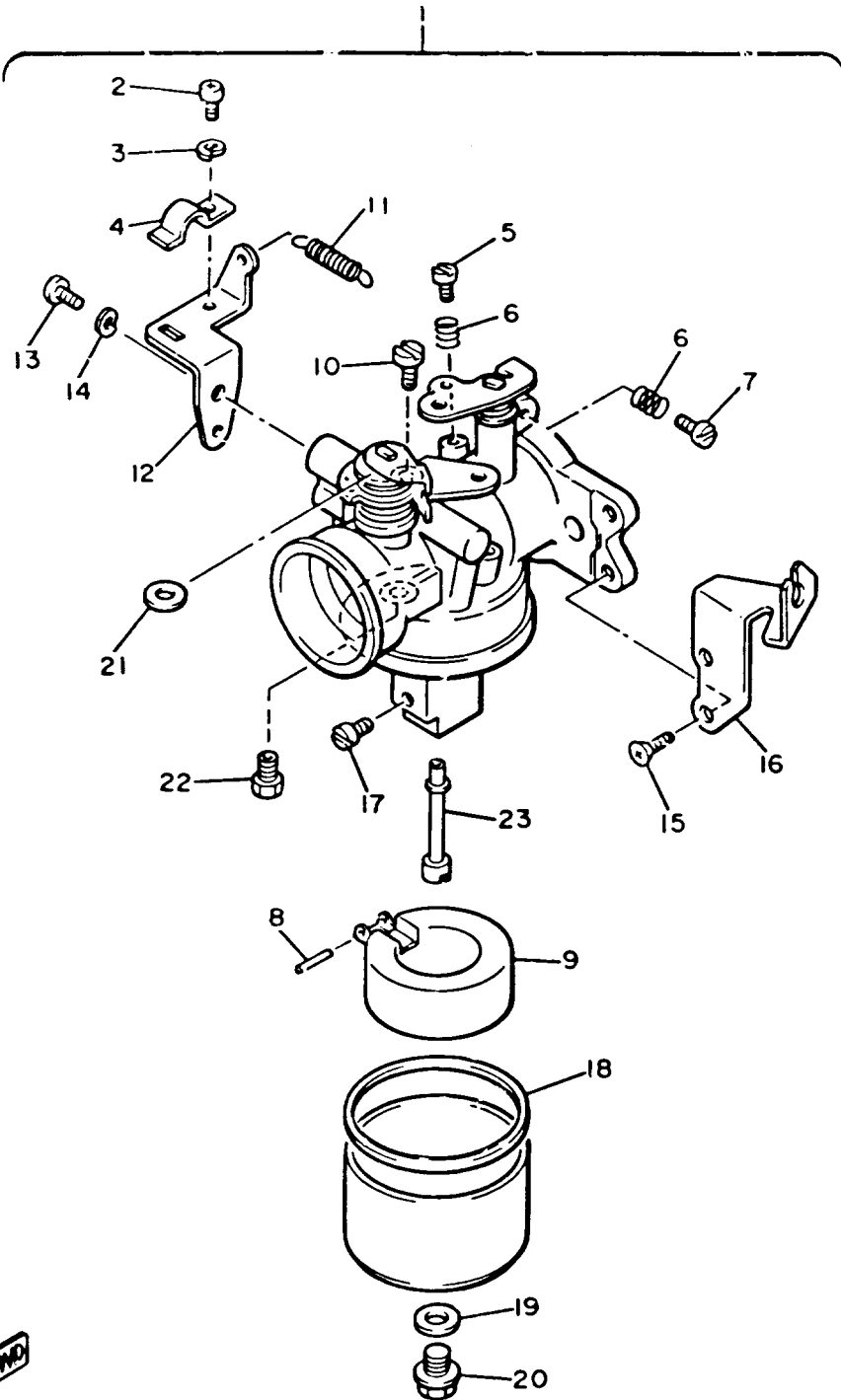

J38110-5060

EXHAUST

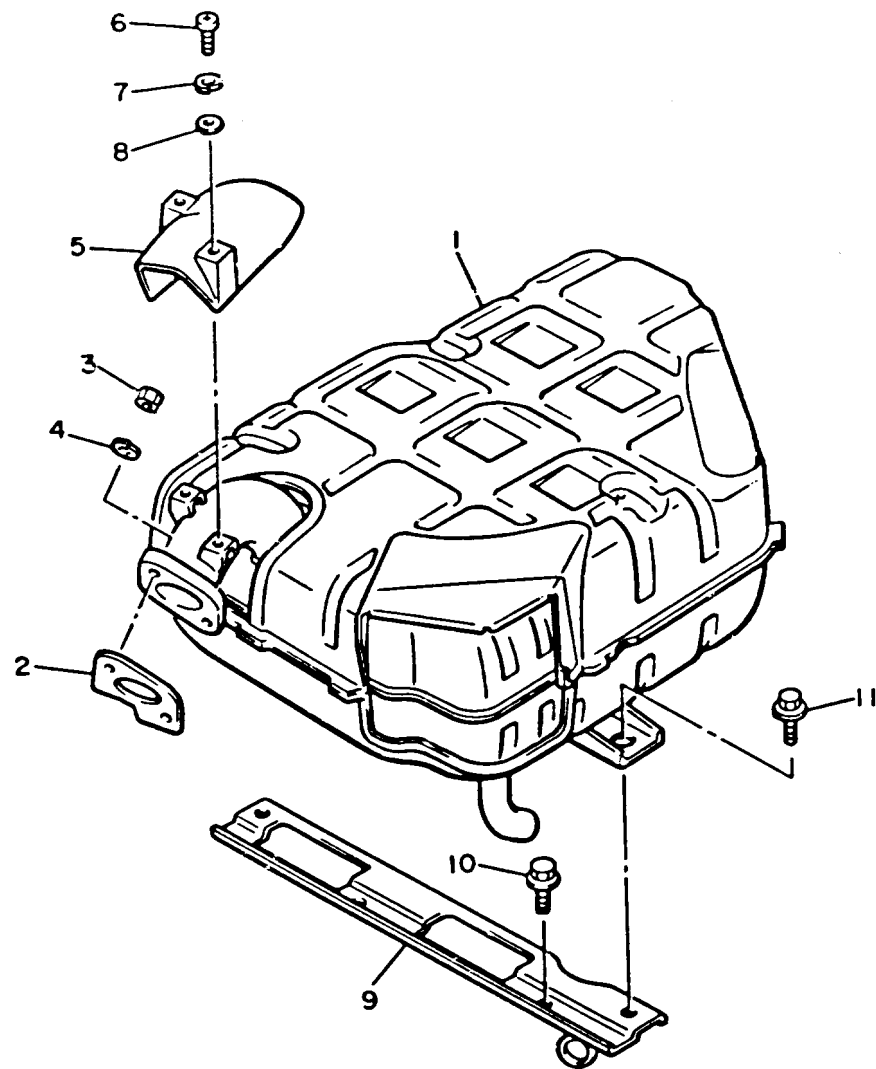

Ref. No.	Part Number	Description	Qty	Remarks
1	J55-E4710-01-00	MUFFLER ASSEMBLY 1	1	
2	J38-14613-01-00	GASKET, EXHAUST PIPE	1	
3	95380-08600-00	NUT	2	
4	92990-08100-00	WASHER	2	
5	J38-14738-00-00	PROTECTOR, muffler 3	1	
6	98580-06012-00	SCREW, PAN HEAD	2	
7	92995-06100-00	WASHER, SPRING	2	
8	92990-06600-00	WASHER, PLATE	2	
9	J38-14771-00-00	STAY, MUFFLER 1	1	
10	95026-10020-00	BOLT, FLANGE	2	
11	90119-08119-00	BOLT, WITH WASHER	2	



J38110-5070

CRANKCASE

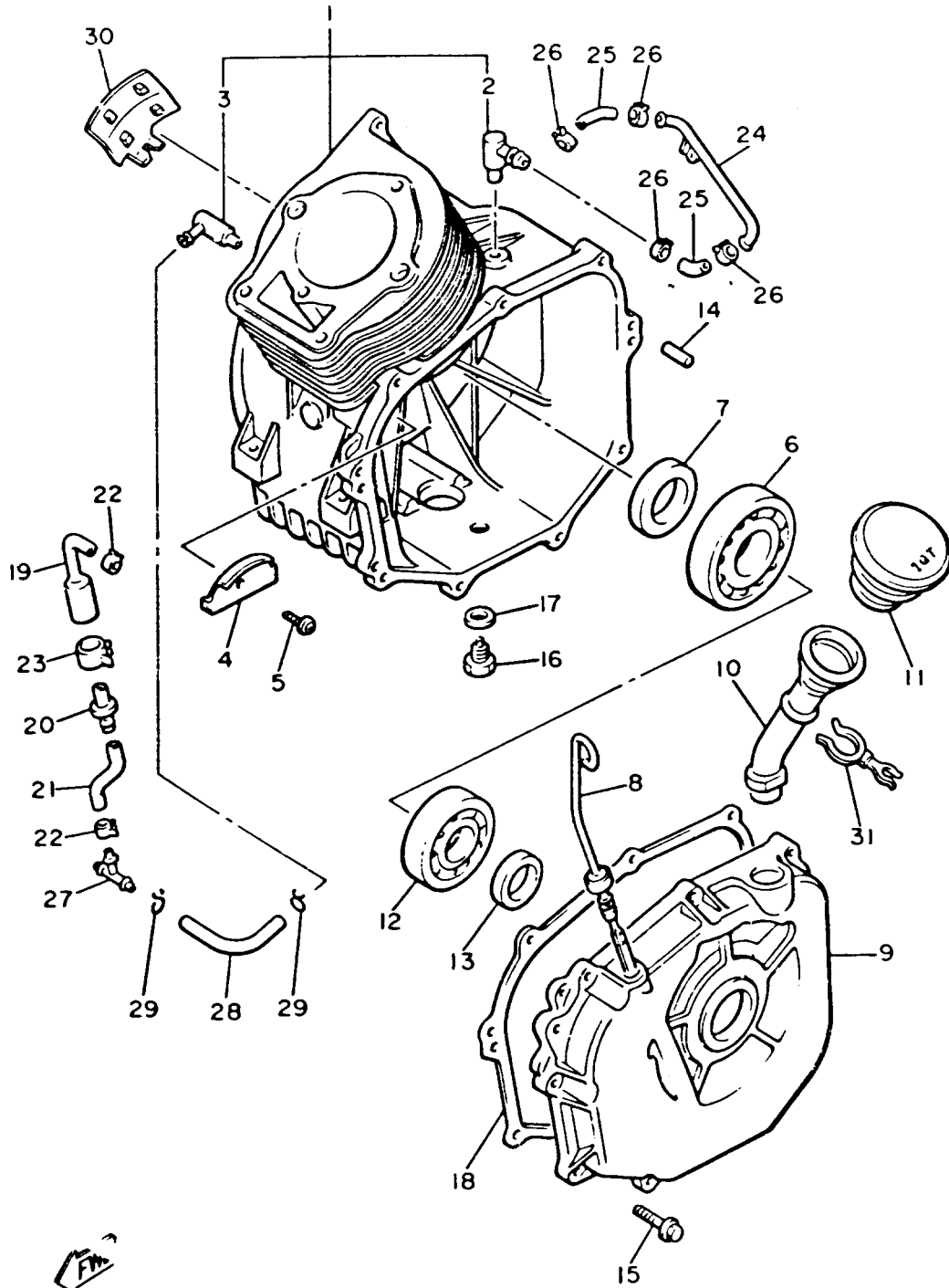

J38100-7080

Ref. No.	Part Number	Description	Qty	Remarks
1	J38-15100-02-00	CRANKCASE ASSEMBLY	1	
2	J38-15148-00-00	. NOZZLE 2	1	
3	J38-15155-00-00	. NOZZLE 3	1	
4	J38-15123-00-00	PLATE, BUFFLE 1	1	
5	90159-05117-00	SCREW, w/washer	1	
6	93306-30709-00	BEARING	1	
7	93102-35191-00	OIL SEAL	1	
8	J38-15361-00-00	GAUGE, LEVEL	1	
9	J38-15411-01-00	COVER, CRANKCASE 1	1	
10	J38-15112-00-00	PIPE, OIL	1	
11	J38-15363-00-00	PLUG, OIL	1	
12	93306-30621-00	BEARING (B6306)	1	
13	93102-30195-00	OIL SEAL	1	
14	93608-12063-00	PIN, DOWEL	2	
15	95811-08035-00	BOLT, FLANGE (95821-08035)	9	
16	90340-12097-00	PLUG, STRAIGHT SCREW	1	
17	90430-12199-00	GASKET	1	
18	J38-15451-00-00	GASKET, CRCS COVERCRANKCASE COVER 1	1	
19	J38-14388-00-00	VALVE, VACUUM CONTROL	1	
20	J38-13115-00-00	CONNECTOR, SUCTION PIPE	1	
21	90445-113E4-00	HOSE	1	
22	90467-10008-00	CLIP	2	
23	90468-08104-00	CLIP	1	
24	J38-13161-00-00	PIPE, DELIVERY 1	1	
25	90445-110E6-00	HOSE	2	
26	90467-10008-00	CLIP	4	
27	807-24376-00-00	PIPE, JOINT 1	1	
28	90445-09073-00	HOSE	1	

CONTINUED ON NEXT FRAME ►

CRANKCASE

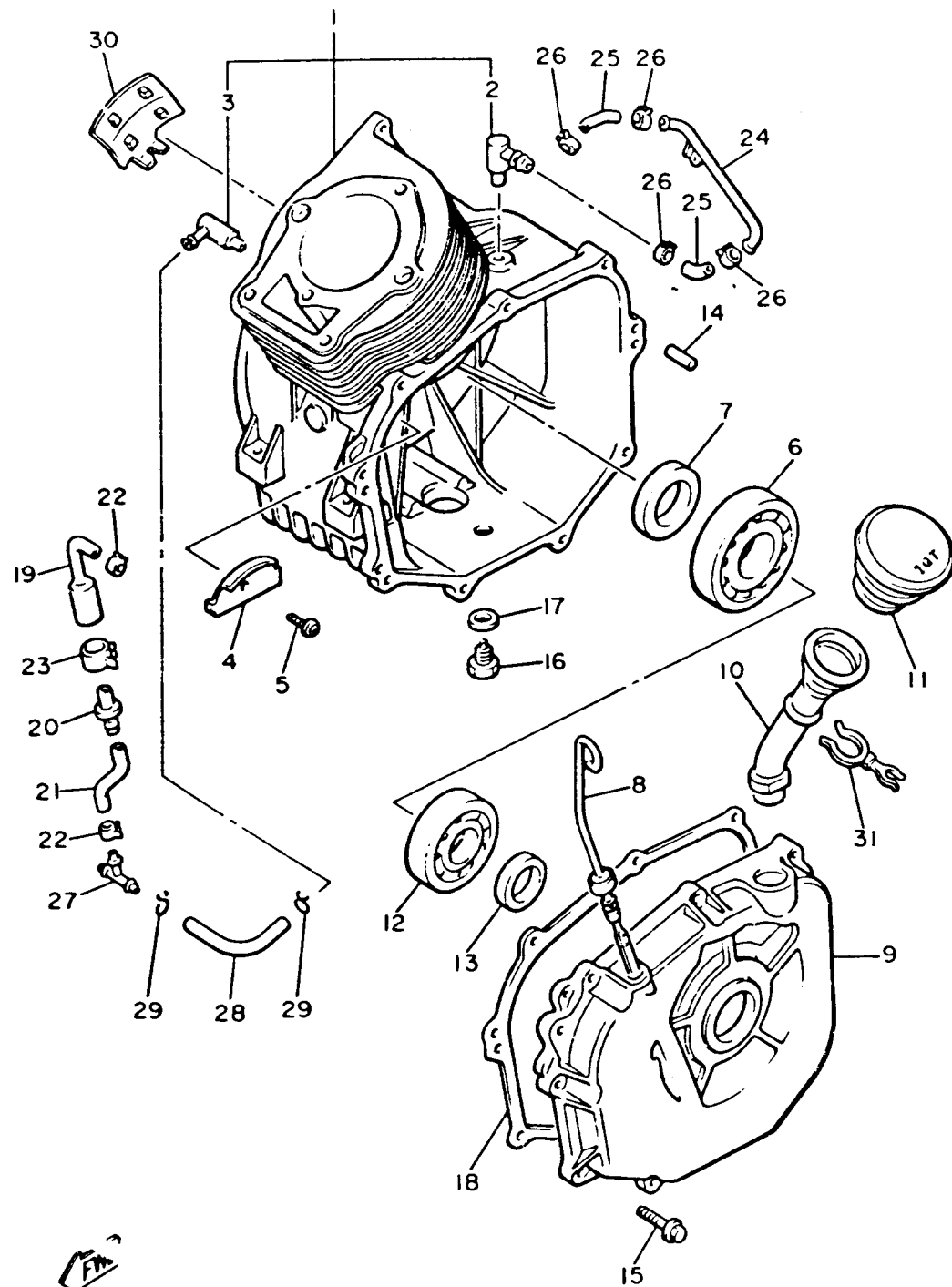

J38100-7080

Ref. No.	Part Number	Description	Qty	Remarks
29	90467-08017-00	CLIP	2	
30	J38-11355-00-00	SEAL, CYLINDER 1	1	
31	90464-26114-00	CLAMP	1	

ENGINE BRACKET

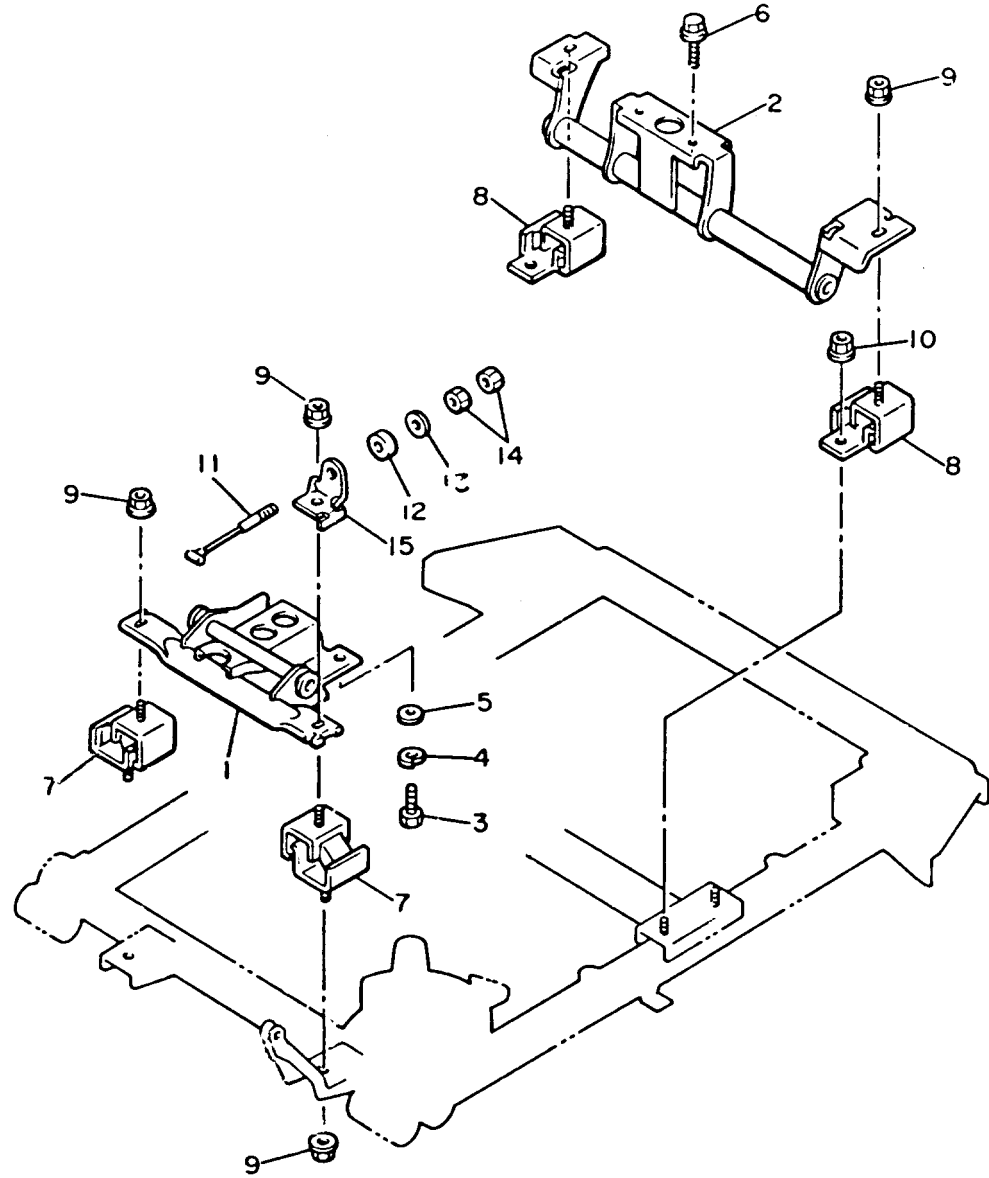

Ref. No.	Part Number	Description	Qty	Remarks
1	J38-21411-02-00	BRACKET, ENGINE 1	1	
2	J55-F1419-00-00	BRACKET, ENGINE 2	1	
3	97011-10025-00	BOLT	2	
4	92990-10100-00	WASHER, SPRING	2	
5	92990-10600-00	WASHER, PLATE	2	
6	95021-10040-00	BOLT, FLANGE	2	
7	J38-21486-00-00	DAMPER 2	2	
8	J38-21488-00-00	DAMPER	2	
9	95701-10500-00	NUT, FLANGE (95702-10500)	6	
10	95701-08500-00	NUT, FLANGE	4	
11	J31-2217J-01-00	TENSIONER 1	1	
12	J17-2214F-00-00	DAMPER 1	1	
13	90201-06778-00	WASHER, PLATE	1	
14	95380-06600-00	NUT	2	
15	J38-2141A-00-00	BRACKET 1	1	



J38100-7090

REAR SHOCKS

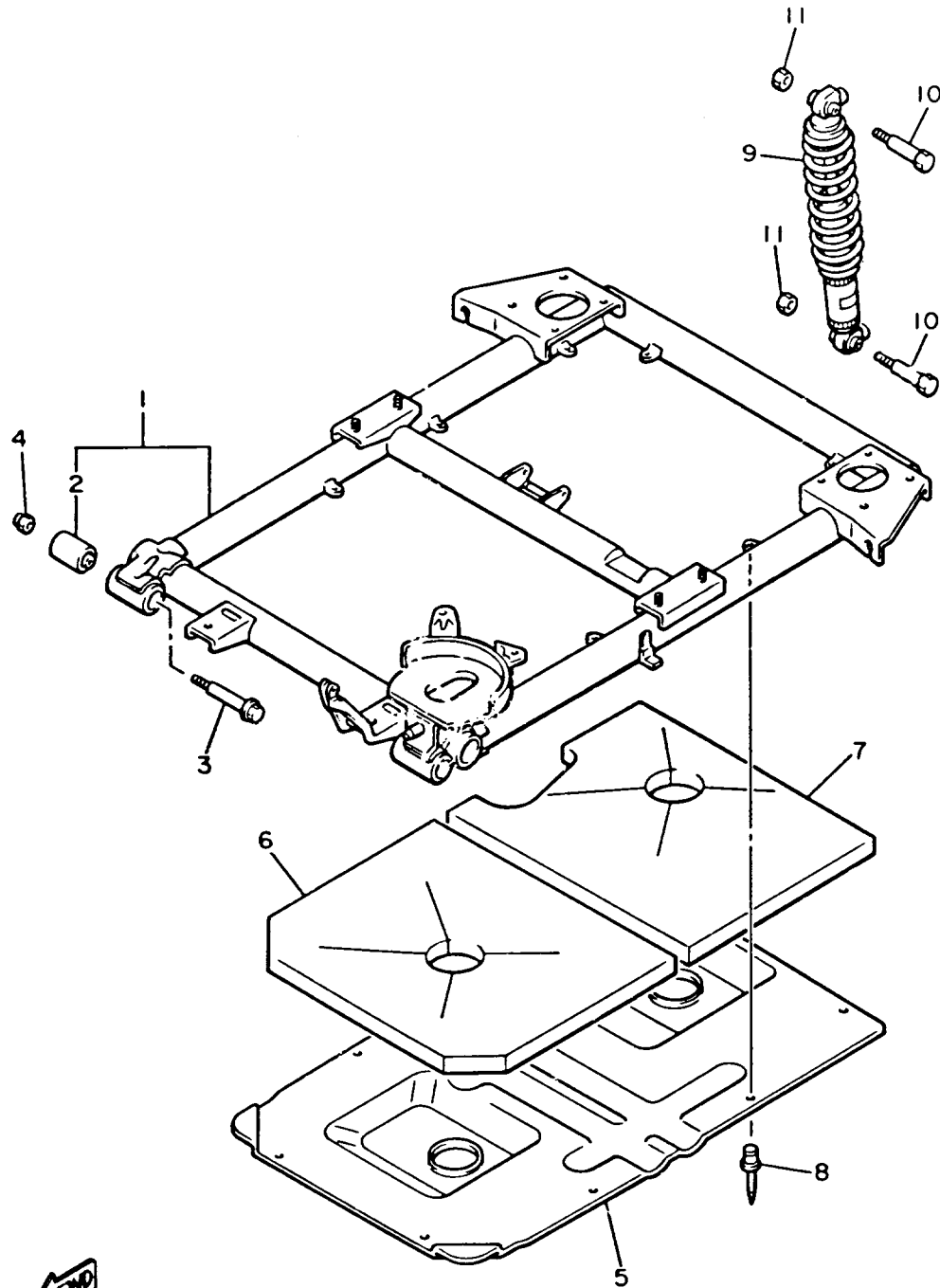

J38110-5100

Ref. No.	Part Number	Description	Qty	Remarks
1	J55-F2110-W0-00	REAR ARM COMP.	1	
2	J10-22123-00-00	. BUSH 1	2	
3	90105-10359-00	BOLT, WASHER BASED	2	
4	90185-10115-00	NUT, SELF-LOCKING	2	
5	J38-22128-00-00	COVER, THRUST 1	1	
6	J55-F211E-00-00	PANEL, INNER 1	1	
7	J55-F211G-00-00	PANEL, INNER 2	1	
8	90267-40127-00	RIVET, BLIND	9	
9	JG5-F2210-00-00	SHOCK ABSORBER ASSEMBLY,	2	
10	97313-10050-00	BOLT, HEXAGON (676)	4	
11	95601-10100-00	NUT, U (95602-10100-00)	4	

FRAME

Ref. No.	Part Number	Description	Qty	Remarks
1	J55-F2501-00-00	FRAME	1	
2	J55-F2571-00-00	PANEL 1	1	
3	J55-F2572-00-00	PANEL 2	1	
4	90267-40054-00	RIVET, BLIND	20	
5	J38-22592-00-00	PLATE 1	1	
6	J38-22593-00-00	PLATE 2	1	
7	95811-06010-00	BOLT, FLANGE	8	
8	J55-K825H-00-00	PAD, SILENCER 4	2	
9	ABA-JF286-00-00	REAR HITCH	1	
10	95811-08050-00	BOLT, FLANGE (95812-08050) .	2	
11	90201-08730-00	WASHER, PLATE	2	
12	95701-08500-00	NUT, FLANGE	2	

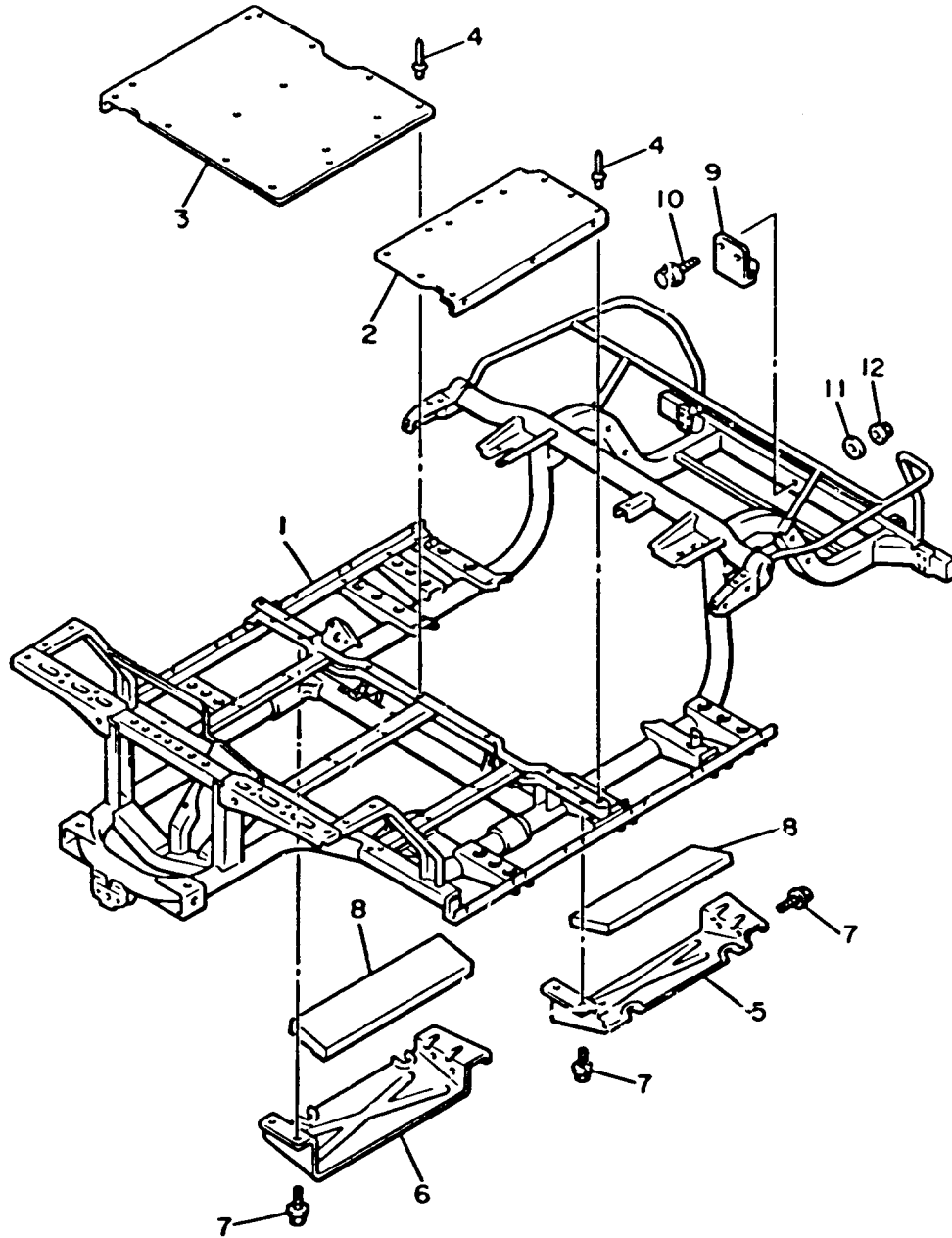

J38110-5111

FRONT SUSPENSION - WHEEL

Ref. No.	Part Number	Description	Qty	Remarks
1	J38-23507-01-00	FRONT LOWER ARM SUB-ASS'Y (L.H) (J38-23507-00)	1	
2	90338-17225-00	. PLUG	1	
3	90386-15139-00	. BUSH	1	
4	J38-23526-00-00	. BUSH	2	
5	J38-23511-01-00	KNUCKLE, STEERING 1	1	
6	J38-23512-02-00	ARM, KNUCKLE 1	1	
7	ABA-JF288-00-00	ARM, STEERING (J41-23532-00)	1	
8	90105-10366-00	BOLT, WASHER BASED	2	
9	90185-10115-00	NUT, SELF-LOCKING	2	
10	91401-25020-00	PIN, COTTER	2	
11	J38-23527-00-00	SEAL, DUST	1	
12	J38-23516-00-00	PIN, STEERING KNUCKLE	1	
13	90201-156J2-00	WASHER, PLAIN	1	
14	J38-23528-00-00	SEAL, DUST	1	
15	91609-60028-00	PIN, SPRING	1	
16	91609-35028-00	PIN, SPRING	1	
17	J38-23508-01-00	FRONT LOWER ARM SUB-ASS'Y (R.H) (J38-23508-00)	1	
18	90338-17225-00	. PLUG	1	
19	90386-15139-00	. BUSH	1	
20	J38-23526-00-00	. BUSH	2	
21	J38-23521-01-00	KNUCKLE, STEERING 2	1	
22	J38-23512-02-00	ARM, KNUCKLE 1	1	
23	90105-10360-00	BOLT, FLANGE	2	
24	90185-10115-00	NUT, SELF-LOCKING	2	
25	91401-25020-00	PIN, COTTER	2	
26	J38-23527-00-00	SEAL, DUST	1	
27	J38-23516-00-00	PIN, STEERING KNUCKLE	1	

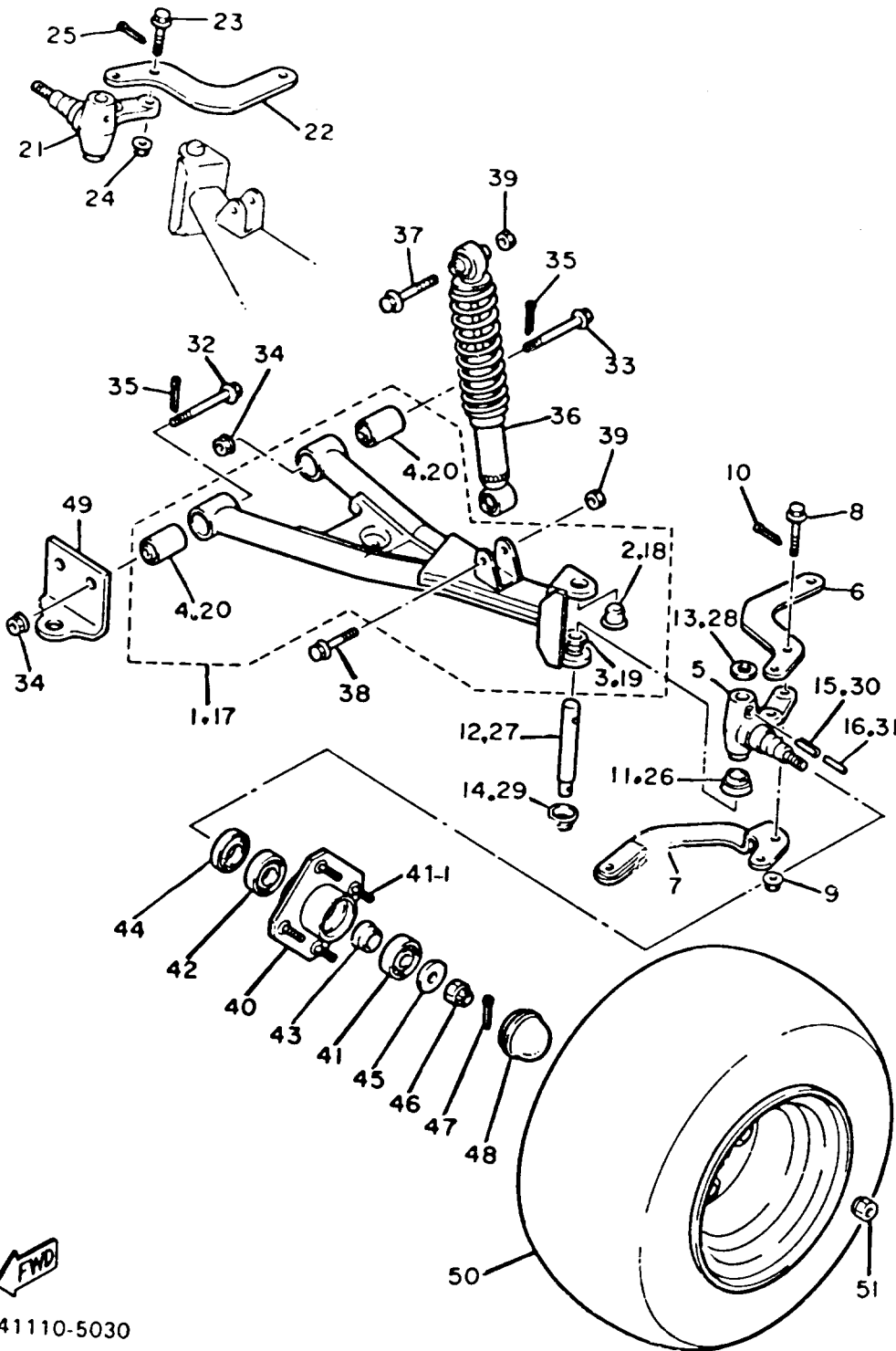

FWD
J41110-5030

CONTINUED ON NEXT FRAME ►

FRONT SUSPENSION - WHEEL

Ref. No.	Part Number	Description	Qty	Remarks
28	90201-156J2-00	WASHER, PLAIN	1	
29	J38-23528-00-00	SEAL, DUST	1	
30	91609-60028-00	PIN, SPRING	1	
31	91609-35028-00	PIN, SPRING	1	
32	90105-10358-00	BOLT, WASHER BASED	2	
33	90105-10357-00	BOLT, FLANGE	2	
34	90185-10115-00	NUT, SELF-LOCKING	4	
35	91401-25020-00	PIN, COTTER	4	
36	JG5-F3350-00-00	SHOCK ABSORBER ASSEMBLY	2	
37	97002-10065-00	BOLT	2	
38	97313-10050-00	BOLT, HEXAGON (676)	2	
39	95601-10100-00	NUT, U (95602-10100-00)	4	
40	J38-W2511-00-00	HUB, FRONT	2	
41	93306-00511-00	BEARING	2	306~
	93306-20421-00	BEARING	2	
42	93306-00510-00	BEARING	2	
	93306-20437-00	BEARING	2	306~
43	90387-241M7-00	COLLAR	2	
44	93102-30083-00	SEAL, OIL	2	
45	90209-32271-00	WASHER	2	
46	95601-14100-00	NUT, U (95602-14100-00)	2	
47	91401-25020-00	PIN, COTTER	2	
48	J17-25118-00-00	COVER, HUB DUST	2	
49	J41-23881-02-00	BRACKET 1 (J41-23881-01)	1	
50	J55-F5100-00-00	FRONT WHEEL ASSEMBLY	2	
51	90179-12262-00	NUT	8	
40-1	90114-12003-00	. BOLT, RIBBED NECK	8	

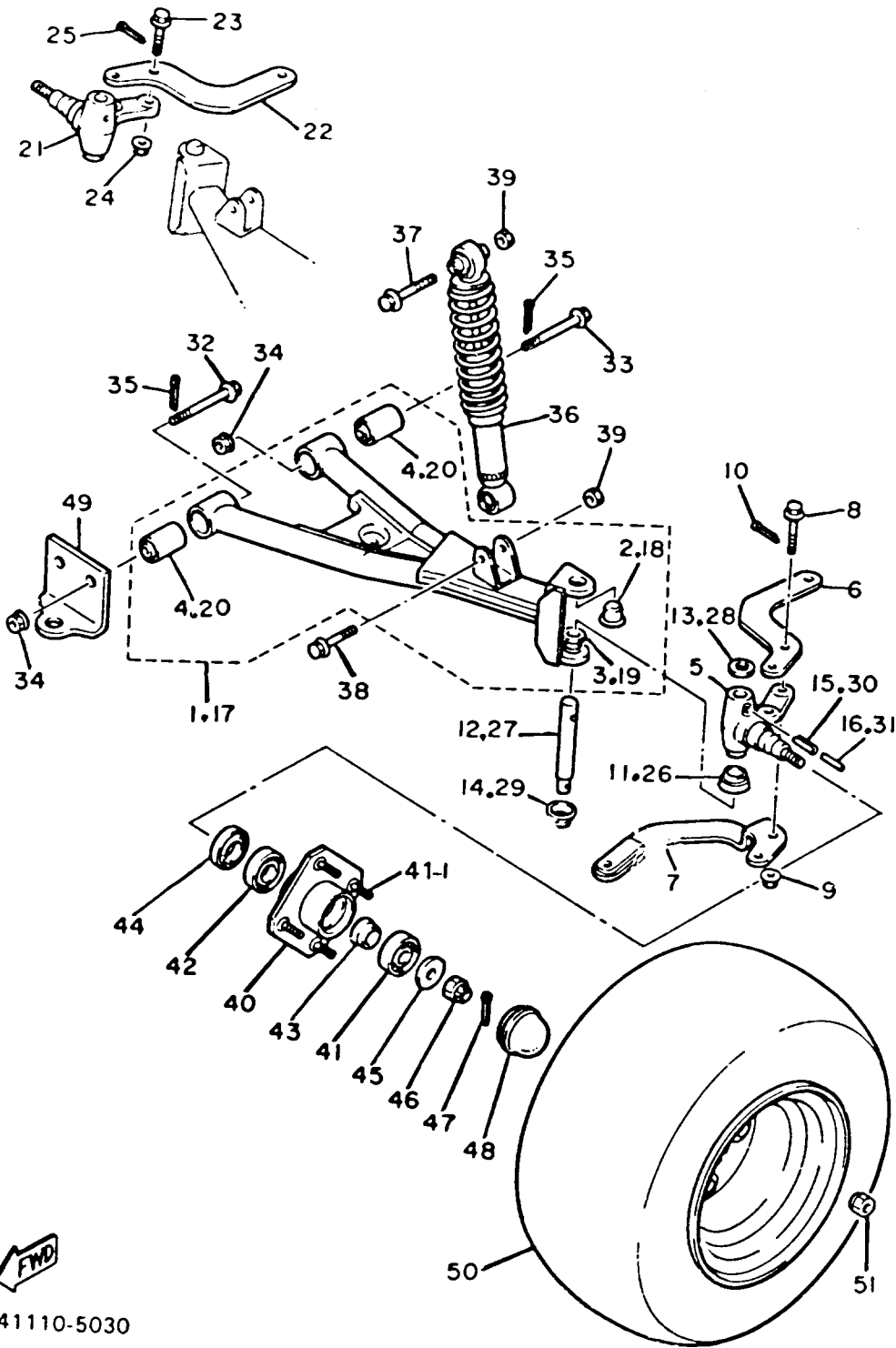

J41110-5030

STEERING

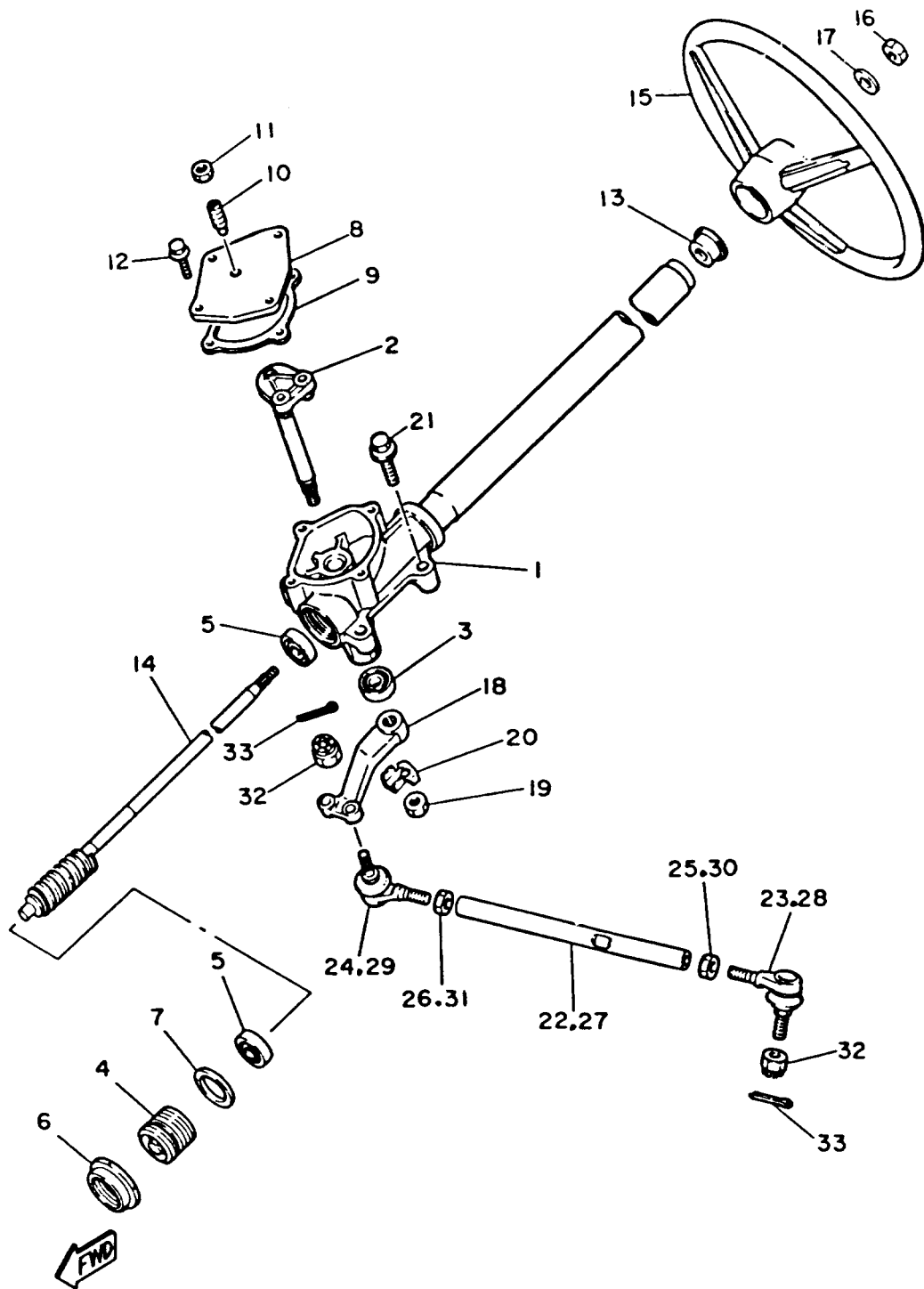

J41110-5040

Ref. No.	Part Number	Description	Qty	Remarks
1	J55-F3811-00-00	COLUMN, STEERING (J38-23811-00)	1	
2	J38-23816-00-00	ARM, PITMAN	1	
3	93102-22087-00	OIL SEAL	1	
4	J55-F3876-00-00	BOLT	1	
5	93332-00010-00	BEARING	2	
6	J10-23877-00-00	NUT	1	
7	J10-23444-00-00	WASHER	1	
8	J55-23818-00-00	COVER, STEERING	1	
9	J38-23462-00-00	SEAL, STEERING (J38-23462-01-00)	1	
10	J10-23459-00-00	BOLT	1	
11	90170-08024-00	NUT, HEX.	1	
12	95811-06020-00	BOLT, FLANGE	4	
13	J38-23814-00-00	HOLDER, HANDLE UPPER	1	
14	J10-23840-00-00	STEERING SHAFT	1	
15	J55-F3838-00-00	WHEEL, STEERING (J10-23838-00)	1	
16	90185-12119-00	NUT, SELF-LOCKING	1	
17	92901-12200-00	WASHER, WAVE	1	
18	J38-23826-01-00	ARM, IDLER	1	
19	95701-16300-00	NUT, FLANGE	1	
20	90215-16252-00	WASHER, TONGUE	1	
21	95811-10050-00	BOLT, FLANGE (95812-10050-00)	4	
22	J38-23831-02-00	ROD, TIE	1	
23	J38-23841-01-00	JOINT, UNIVERSAL 1	1	
24	J38-23845-01-00	JOINT, UNIVERSAL 2	1	
25	90170-12055-00	NUT	1	
26	90170-12054-00	NUT	1	

CONTINUED ON NEXT FRAME ►

STEERING

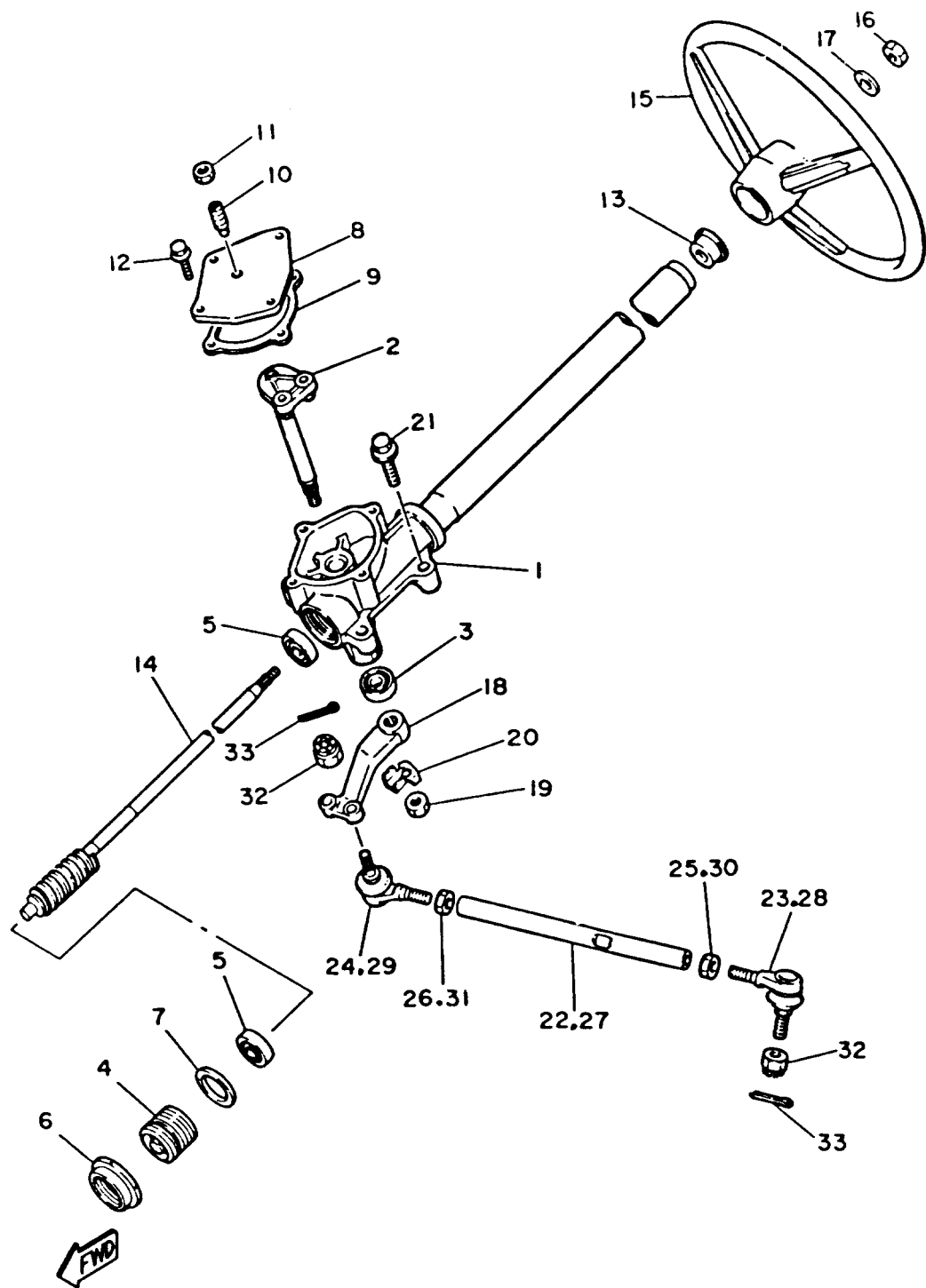

J41110-5040

Ref. No.	Part Number	Description	Qty	Remarks
27	J38-23837-02-00	ROD, TIE 2	1	
28	J38-23841-01-00	JOINT, UNIVERSAL 1	1	
29	J38-23845-01-00	JOINT, UNIVERSAL 2	1	
30	90170-12055-00	NUT	1	
31	90170-12054-00	NUT	1	
32	95601-10100-00	NUT, U (95602-10100-00)	4	
33	91401-25020-00	PIN, COTTER	4	

FUEL TANK

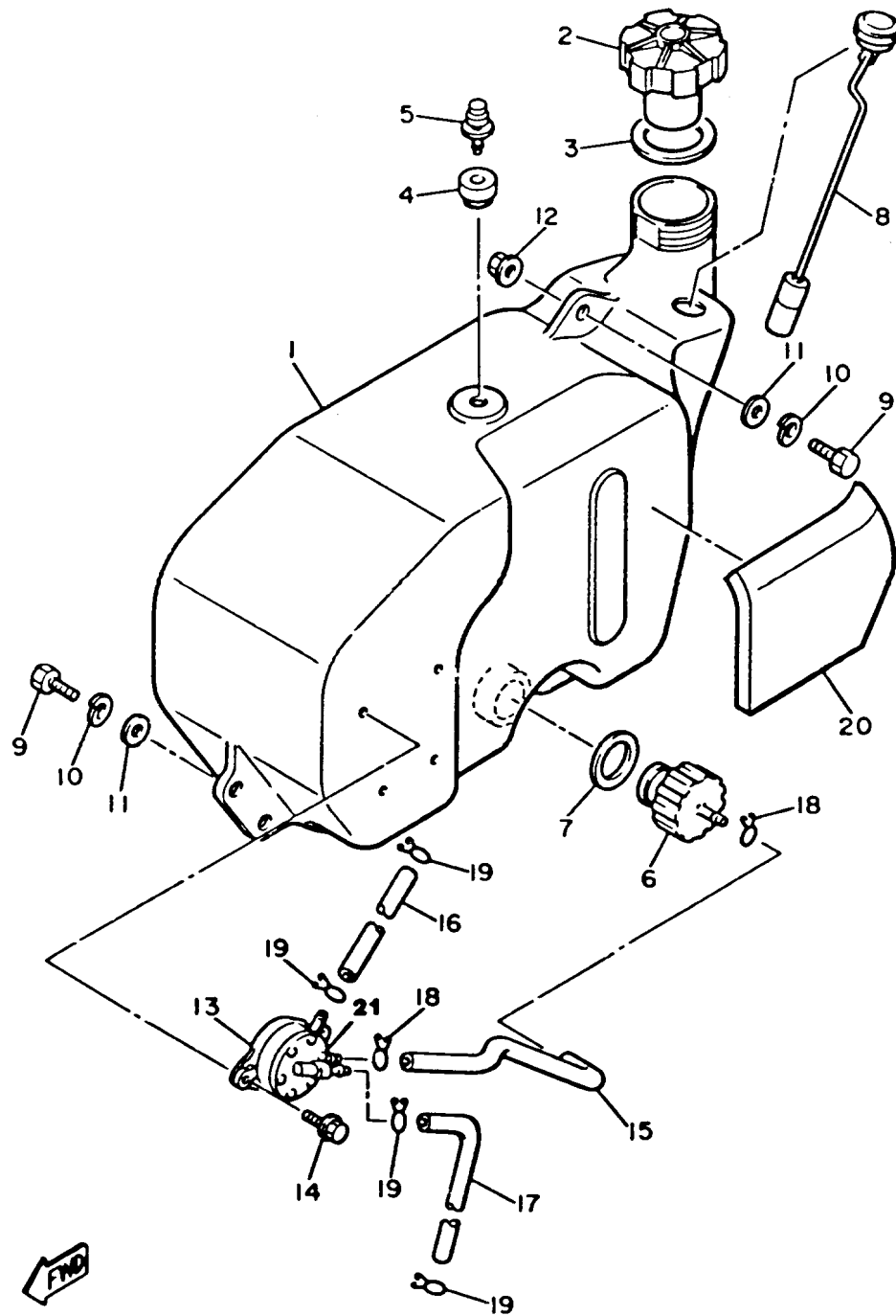

J38110-5140

Ref. No.	Part Number	Description	Qty	Remarks
1	J55-F4111-00-00	FUEL TANK	1	
2	J24-24620-01-00	BODY CAP ASSEMBLY	1	
3	J10-24612-00-00	GASKET, CAP	1	
4	J10-21773-00-00	GROMMET	1	
5	J24-24460-01-00	RELEASE VALVE ASSEMBLY.	1	
6	8R4-24560-00-00	FILTER ASSEMBLY.	1	
7	8F3-24564-00-00	GASKET	1	
8	J38-85710-02-00	FUEL LEVEL GAUGE ASSEMBLY.	1	
9	97001-08025-00	BOLT (1NV)	3	
10	92990-08100-00	WASHER	3	
11	90201-08748-00	WASHER, PLATE	3	
12	95701-08500-00	NUT, FLANGE	1	
13	J38-24410-10-00	FUEL PUMP ASSEMBLY	1	
14	95811-06016-00	BOLT, FLANGE (95822-06016) .	2	
15	J38-24311-00-00	PIPE, FUEL 1	1	
16	90445-09225-00	HOSE	1	
17	90445-09085-00	HOSE	1	
18	90467-11009-00	CLIP	2	
19	90467-08017-00	CLIP	4	
20	J55-F4129-00-00	COVER, SIDE 1 (J38-24129-00)	1	
21	38W-W1391-01-00	FUEL PUMP SEAL SET	1	
	J38-24452-18-00	COVER, FUEL PUMP	1	

BRAKE

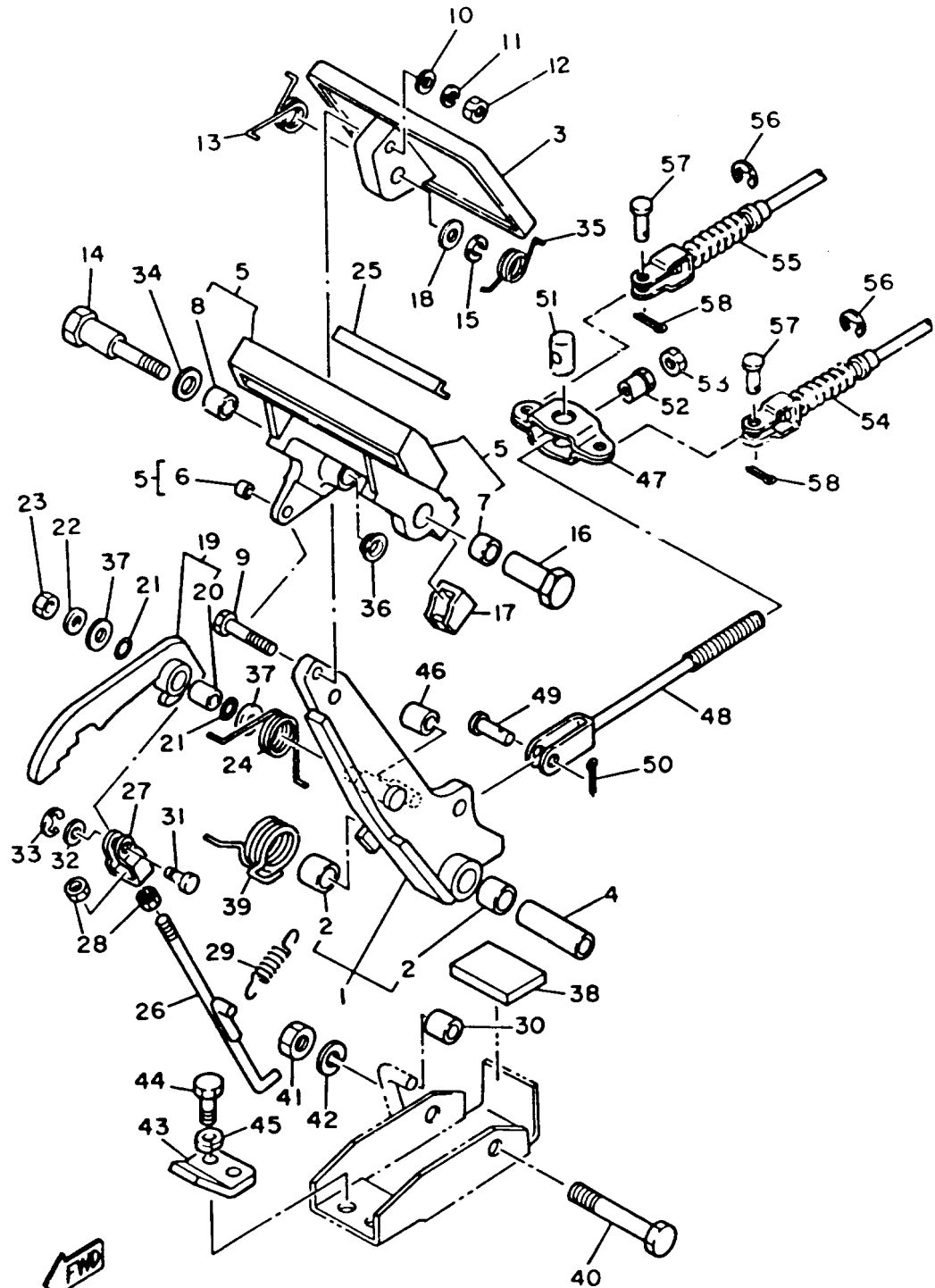

J41110-5050

Ref. No.	Part Number	Description	Qty	Remarks
1	92990-10600-00	. WASHER, PLATE	1	
	99080-07600-00	. CIRCLIP (E)	1	
	99999-01757-00	BRAKE ARM CMLPT (J17-27250-01)	1	
	J17-27250-02-00	. BRAKE ARM COMP.	1	
2	90384-14080-00	. BUSH, BIMETAL	2	
3	J10-27211-00-00	PEDAL, BRAKE	1	
4	90387-107F8-00	COLLAR	1	
5	99999-01799-00	PARKING PEDAL COMP. (J17-25670-00)	1	
	J17-25670-01-00	. PARKING PEDAL COMP.	1	
	J17-25679-01-00	. DAMPER	2	
6	90384-05163-00	. BUSH, BIMETAL	1	
7	90384-12164-00	. BUSH, BIMETAL	1	
8	90380-12051-00	. BUSH, SOLID	1	
9	90101-06555-00	BOLT, HEX.	1	
10	92990-06200-00	WASHER	1	
11	92995-06100-00	WASHER, SPRING	1	
12	95380-06600-00	NUT	1	
13	90508-23542-00	SPRING, TORSION	1	
14	90109-08669-00	BOLT	1	
15	92990-08100-00	WASHER	1	
16	90179-08378-00	NUT	1	
17	J17-25679-01-00	DAMPER	2	
18	92990-08200-00	WASHER, PLAIN	1	
19	J17-W2561-00-00	SECTOR, PARKING BRAKE ..	1	
20	90384-10162-00	. BUSH, BIMETAL	1	
21	J17-27221-00-00	SEAL, SHAFT	2	
22	90201-065F3-00	WASHER, PLATE	1	

CONTINUED ON NEXT FRAME ►

BRAKE

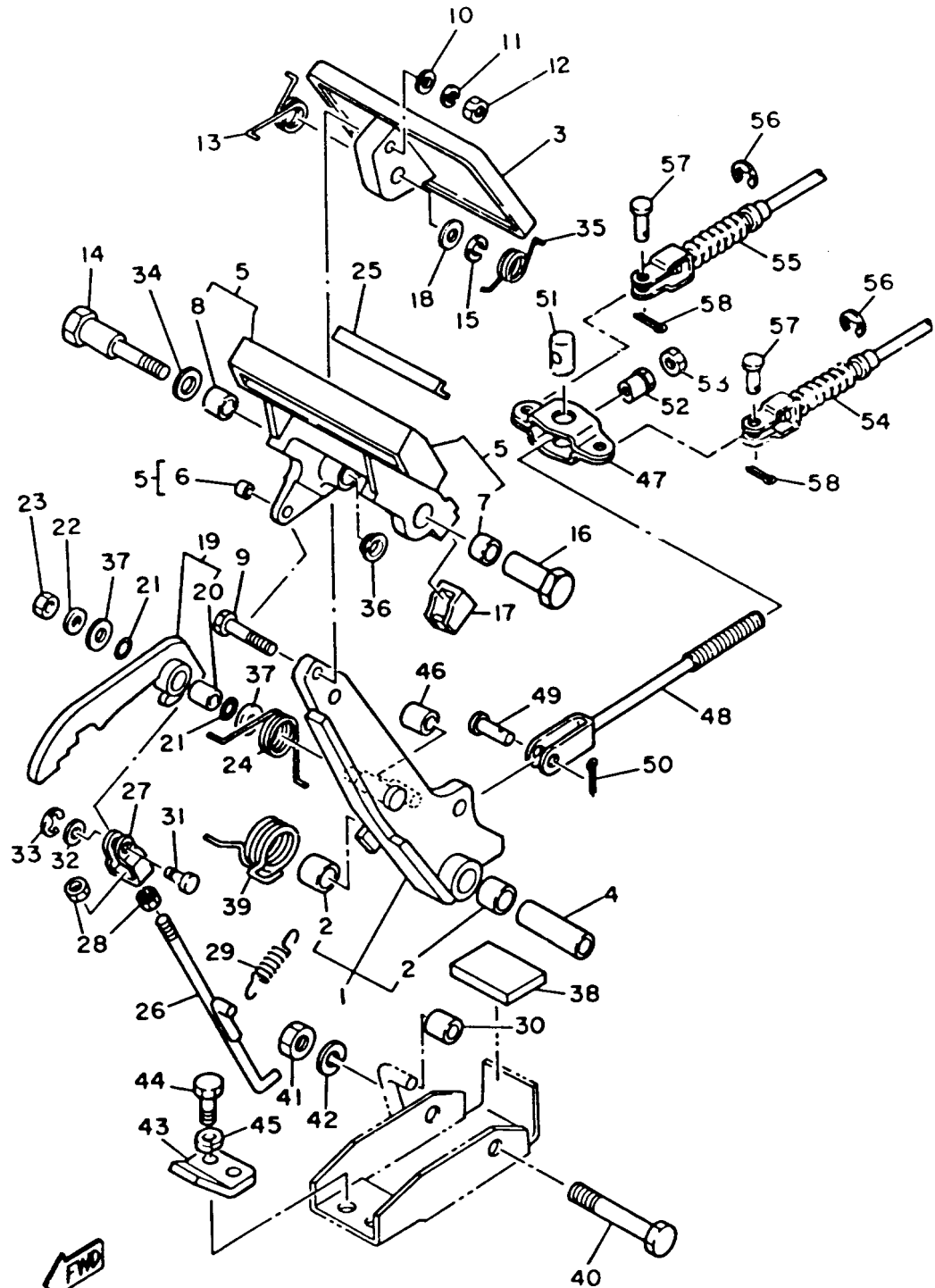

J41110-5050

Ref. No.	Part Number	Description	Qty	Remarks
23	95601-06100-00	NUT, U	1	
24	90508-14548-00	SPRING, TORSION	1	
25	J17-25672-00-00	PAD, PARKING PEDAL	1	
26	J17-27231-00-00	ROD, BRAKE	1	
27	J17-27232-00-00	END, ROD	1	
28	95380-06700-00	NUT	2	
29	90506-12277-00	SPRING, TENSION	1	
30	J17-25673-00-00	DAMPER, BRAKE	1	
31	J17-27228-00-00	PIN, LINK JOINT	1	
32	92901-05600-00	WASHER, PLATE	1	
33	99080-04600-00	CIRCLIP (E)	1	
34	90201-123F2-00	WASHER, PLAIN	1	
35	90508-26557-00	SPRING, TORSION	1	
36	90380-12105-00	BUSH, SOLID	1	
37	90201-104G8-00	WASHER, PLAIN	2	
38	J17-27245-00-00	PAD, BRAKE PEDAL	1	
39	90508-40543-00	SPRING, TORSION	1	
40	90101-10447-00	BOLT, HEX.	1	
41	95601-10100-00	NUT, U (95602-10100-00)	1	
42	92990-10100-00	WASHER, SPRING	1	
43	J17-27246-00-00	NAIL, BRAKE	1	
44	97313-08020-00	BOLT, HEXAGON	2	
45	92990-08100-00	WASHER	2	
46	J17-25673-00-00	DAMPER, BRAKE	1	
47	J10-25681-00-00	EQUALIZER, BRAKE	1	
48	J20-25685-00-00	ROD	1	
49	91701-10022-00	PIN	1	
50	91490-30020-00	PIN, COTTER	1	
51	90249-14129-00	PIN	1	

CONTINUED ON NEXT FRAME ►

BRAKE

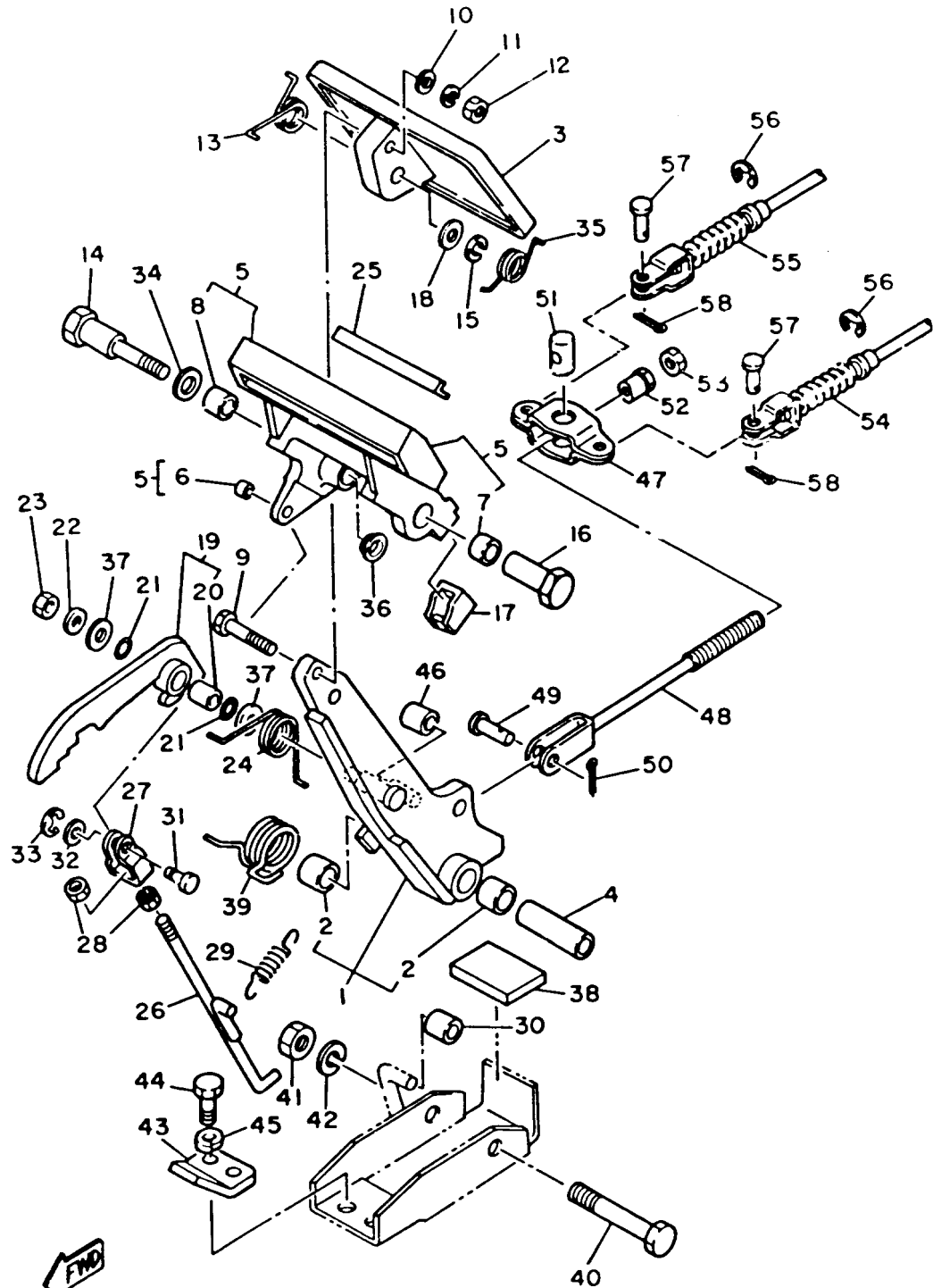

J41110-5050

Ref. No.	Part Number	Description	Qty	Remarks
52	90179-08261-00	NUT	1	
53	95303-08700-00	NUT	1	
54	J55-F6341-00-00	CABLE, BRAKE	1	
55	J55-F6351-00-00	CABLE, BRAKE	1	
56	99001-09600-00	CIRCLIP	4	
57	91701-08018-00	PIN	4	
58	91490-25020-00	PIN, COTTER	4	

BRAKE 2

Ref. No.	Part Number	Description	Qty	Remarks
1	J17-27208-00-00	BACKING PLATE SUB ASSEMBLY 1 (R.H)	1	
2	J55-W2536-00-00	BRAKE SHOE SET	1	
3	J17-27206-00-00	ANCHOR BODY COMP.	1	
4	J38-27204-00-00	LEVER ASSEMBLY 1	1	
5	J55-25358-00-00	. SPRING LEVER	1	
6	J10-27281-00-00	SPRING, SHOE CLAMP	2	
7	J10-27282-00-00	PIN, SHOE HOLD DOWN	2	
8	90506-20281-00	SPRING, TENSION	1	
9	90506-26191-00	SPRING, TENSION	1	
10	J55-27270-00-00	ADJUSTER ASSEMBLY	1	
11	J10-27286-00-00	COVER, DUST	1	
12	92990-06100-00	WASHER, SPRING	2	
13	95380-06600-00	NUT	2	
14	90201-121H8-00	WASHER, PLATE	1	
15	90201-121H9-00	WASHER, PLATE	1	
16	97011-08016-00	BOLT	4	
17	92902-08100-00	WASHER, SPRING	4	

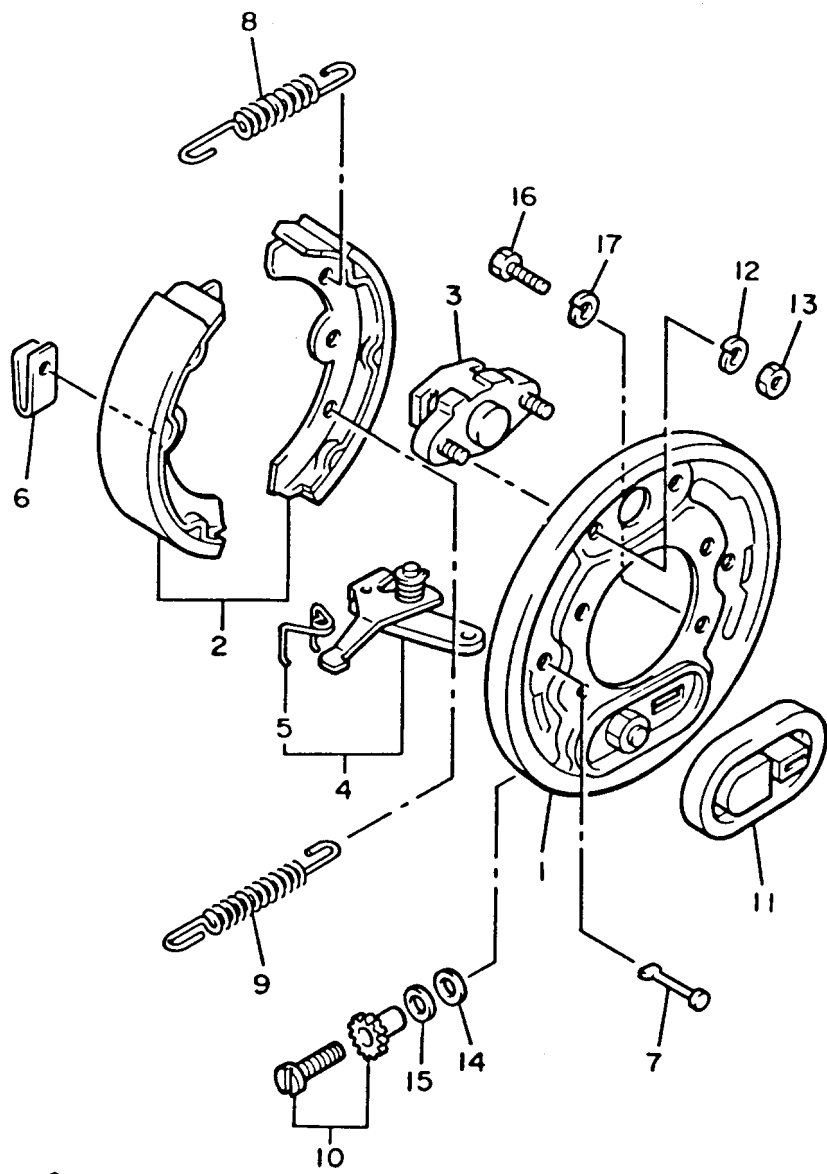

JG5100-1170

BRAKE 3

Ref. No.	Part Number	Description	Qty	Remarks
1	J17-27209-00-00	BACKING PLATE SUB ASSEMBLY 2 (L.H)	1	
2	J55-W2536-00-00	BRAKE SHOE SET	1	
3	J17-27206-00-00	ANCHOR BODY COMP.	1	
4	J38-27205-00-00	LEVER ASSEMBLY 2	1	
5	J55-25357-00-00	. SPRING, LEVER	1	
6	J10-27281-00-00	SPRING, SHOE CLAMP	2	
7	J10-27282-00-00	PIN, SHOE HOLD DOWN	2	
8	90506-20281-00	SPRING, TENSION	1	
9	90506-26191-00	SPRING, TENSION	1	
10	J55-27260-00-00	ADJUSTER ASSEMBLY	1	
11	J10-27286-00-00	COVER, DUST	1	
12	92995-06100-00	WASHER, SPRING	2	
13	95380-06600-00	NUT	2	
14	90201-121H8-00	WASHER, PLATE	1	
15	90201-121H9-00	WASHER, PLATE	1	
16	97011-08016-00	BOLT	4	
17	92990-08100-00	WASHER	4	

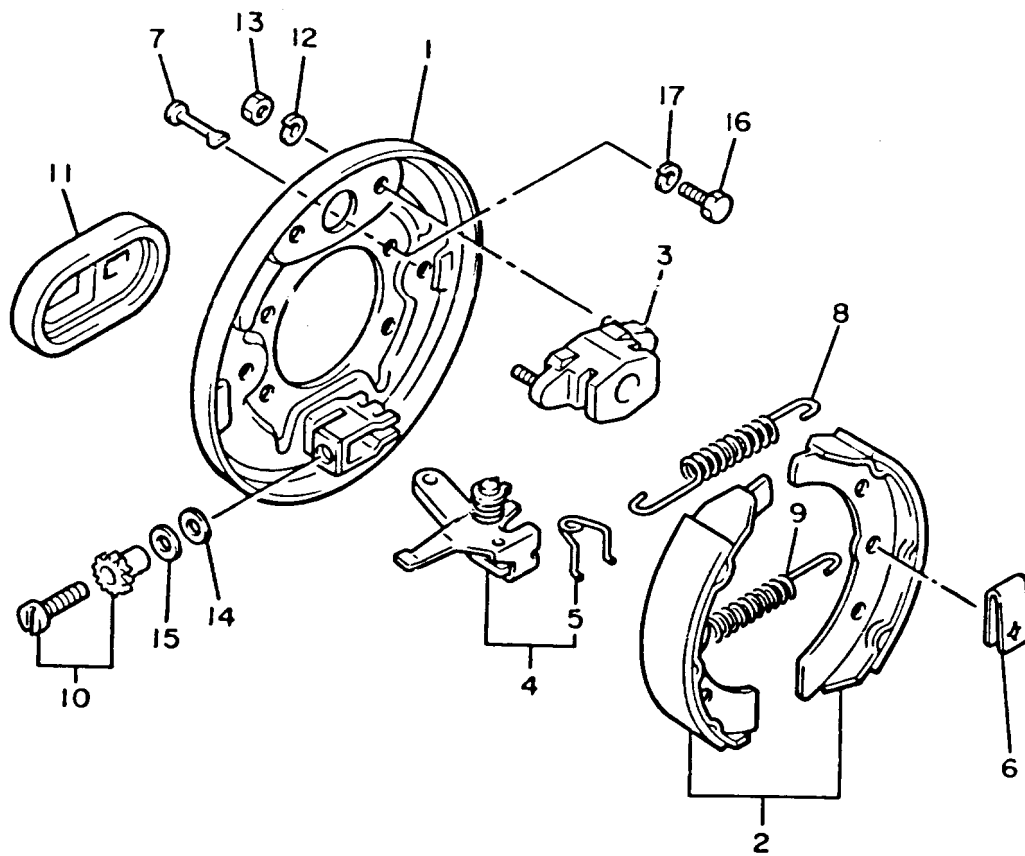

JG5100-1:60

ACCELERATOR

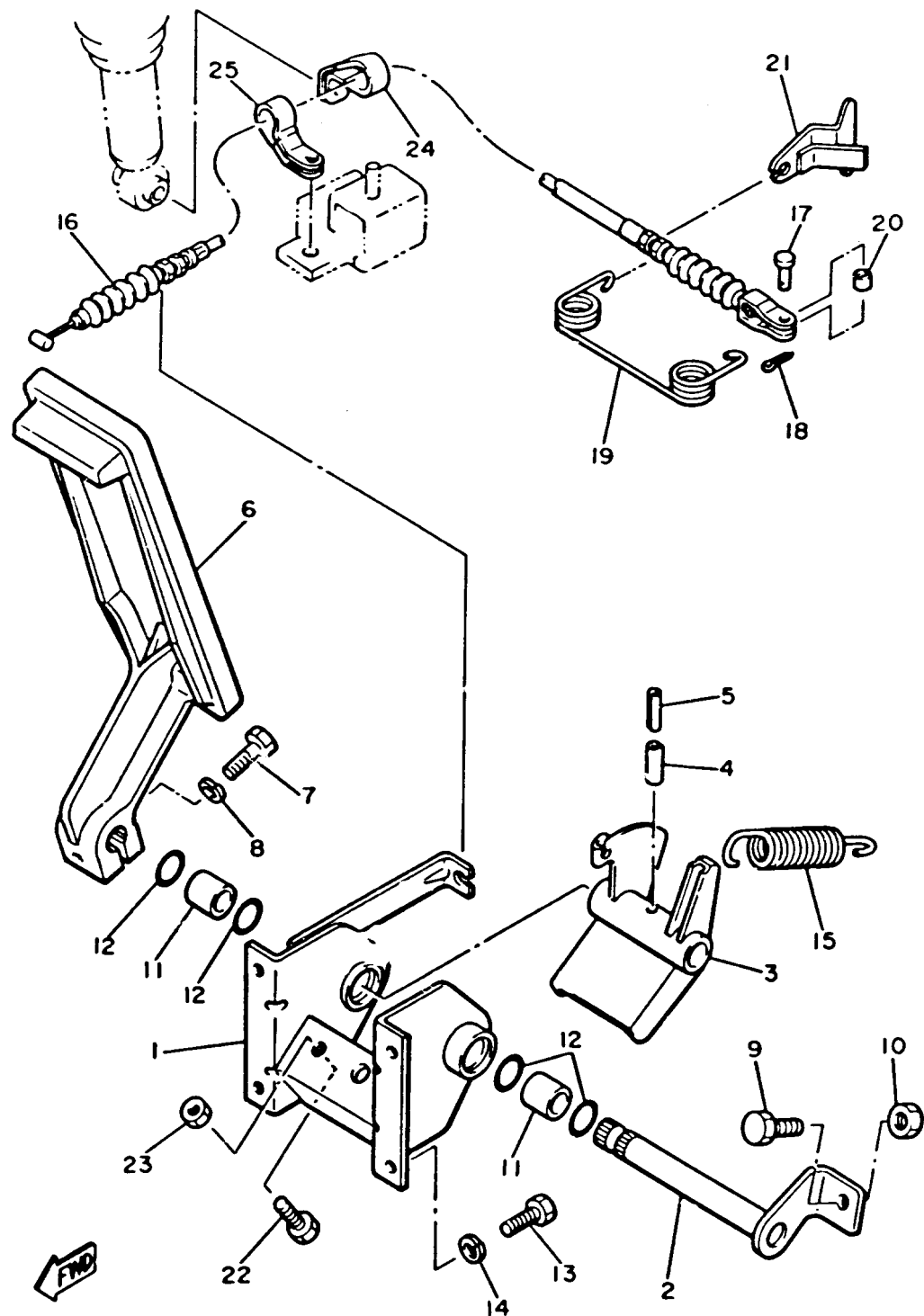

J38110-5170

Ref. No.	Part Number	Description	Qty	Remarks
1	J38-27874-00-00	BRACKET, ACCELERATOR PEDAL	1	
2	J17-27853-00-00	SHAFT, PEDAL 1	1	
3	J38-27872-00-00	ARM, ACCELERATOR	1	
4	91609-60028-00	PIN, SPRING	1	
5	91609-35028-00	PIN, SPRING	1	
6	JF3-27871-00-00	PEDAL, ACCELERATOR	1	
7	97011-06025-00	BOLT (97001-06025)	1	
8	92995-06100-00	WASHER, SPRING	1	
9	90106-08040-00	BOLT, RD. HEX	1	
10	95303-08700-00	NUT	1	
11	90384-14080-00	BUSH, BIMETAL	2	
12	93210-14104-00	O-RING	4	
13	97313-06016-00	BOLT, HEXAGON	4	
14	92990-06100-00	WASHER, SPRING	4	
15	90506-26282-00	SPRING, TENSION	1	
16	J55-F6311-00-00	CABLE, THROTTLE 1	1	
17	91702-05012-00	PIN	1	
18	90468-10050-00	CLIP	1	
19	90508-16460-00	SPRING, TORSION	1	
20	90560-05001-00	SPACER	1	
21	J38-27981-00-00	BRACKET, THROTTLE	1	
22	97011-06025-00	BOLT (97001-06025)	1	
23	95380-06700-00	NUT	1	
24	90461-08048-00	CLAMP	1	
25	90461-08106-00	CLAMP	1	

GOVERNOR

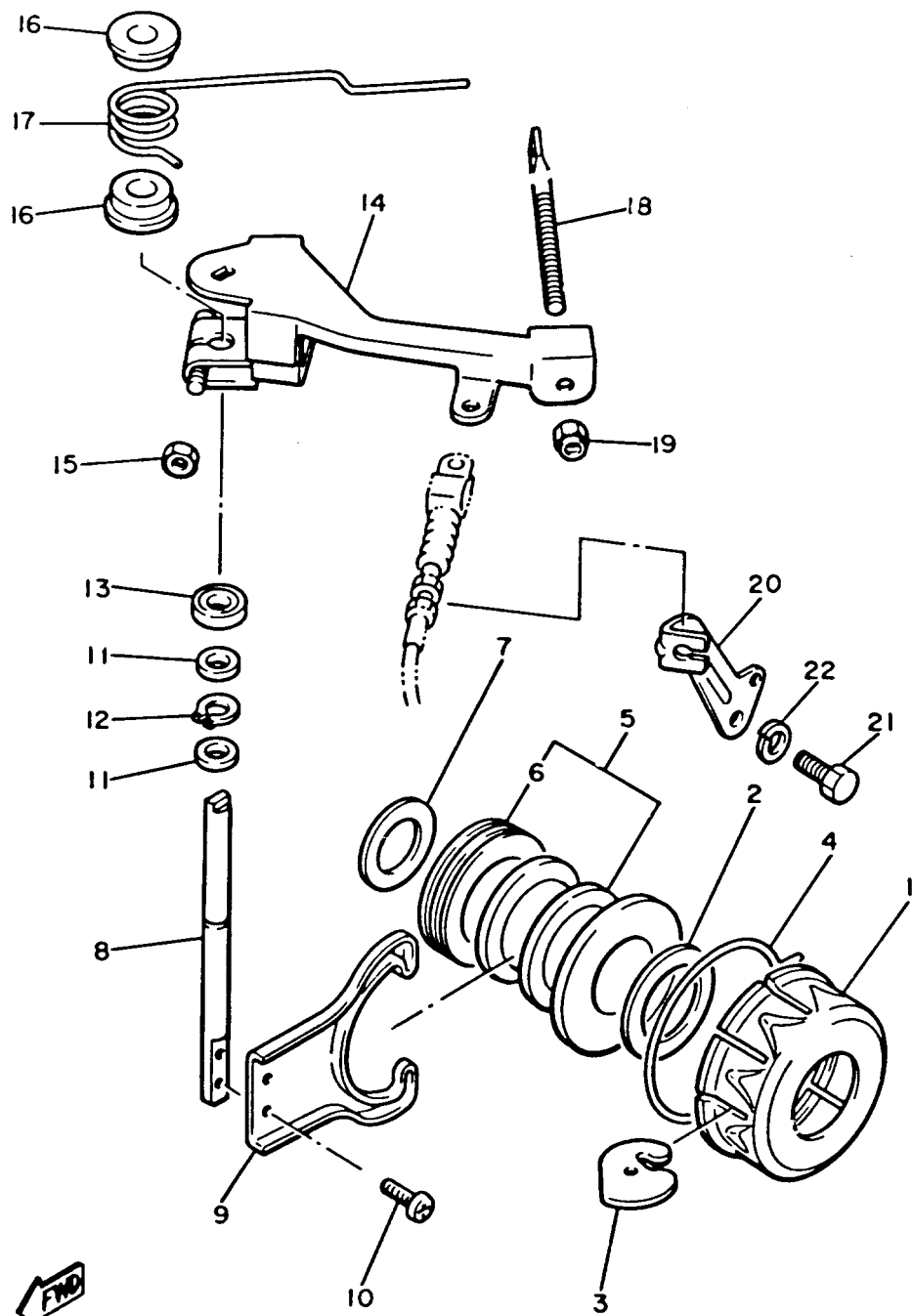

Ref. No.	Part Number	Description	Qty	Remarks
1	J10-27912-00-00	RETAINER	1	
2	90387-21690-00	COLLAR	1	
3	J10-27913-00-00	WEIGHT	12	
4	J10-27911-00-00	HOLDER	1	
5	J10-27927-00-00	LIFTER	1	
6	93342-22502-00	. BEARING, THRUST	1	
7	90201-20275-00	WASHER, PLATE	1	
8	J38-27921-00-00	SHAFT, GOVERNOR	1	
9	J10-27922-00-00	FORK, GOVERNOR	1	
10	98580-04008-00	SCREW, PAN HEAD	2	
11	90202-08110-00	WASHER, PLATE	2	
12	99009-06600-00	CIRCLIP	1	
13	93109-08050-00	OIL SEAL	1	
14	J38-27951-00-00	LEVER, SPEED	1	
15	95380-06600-00	NUT	1	
16	90386-08141-00	BUSH	2	
17	90508-40678-00	SPRING, TORSION	1	
18	J38-27959-00-00	SCREW, ADJUSTING	1	
19	95701-06300-00	NUT, NYLON	1	
20	J38-27982-00-00	BRACKET, WIRE	1	
21	97022-08016-00	BOLT	1	
22	92990-08100-00	WASHER	1	

J38110-5180

PRIMARY SHEAVE

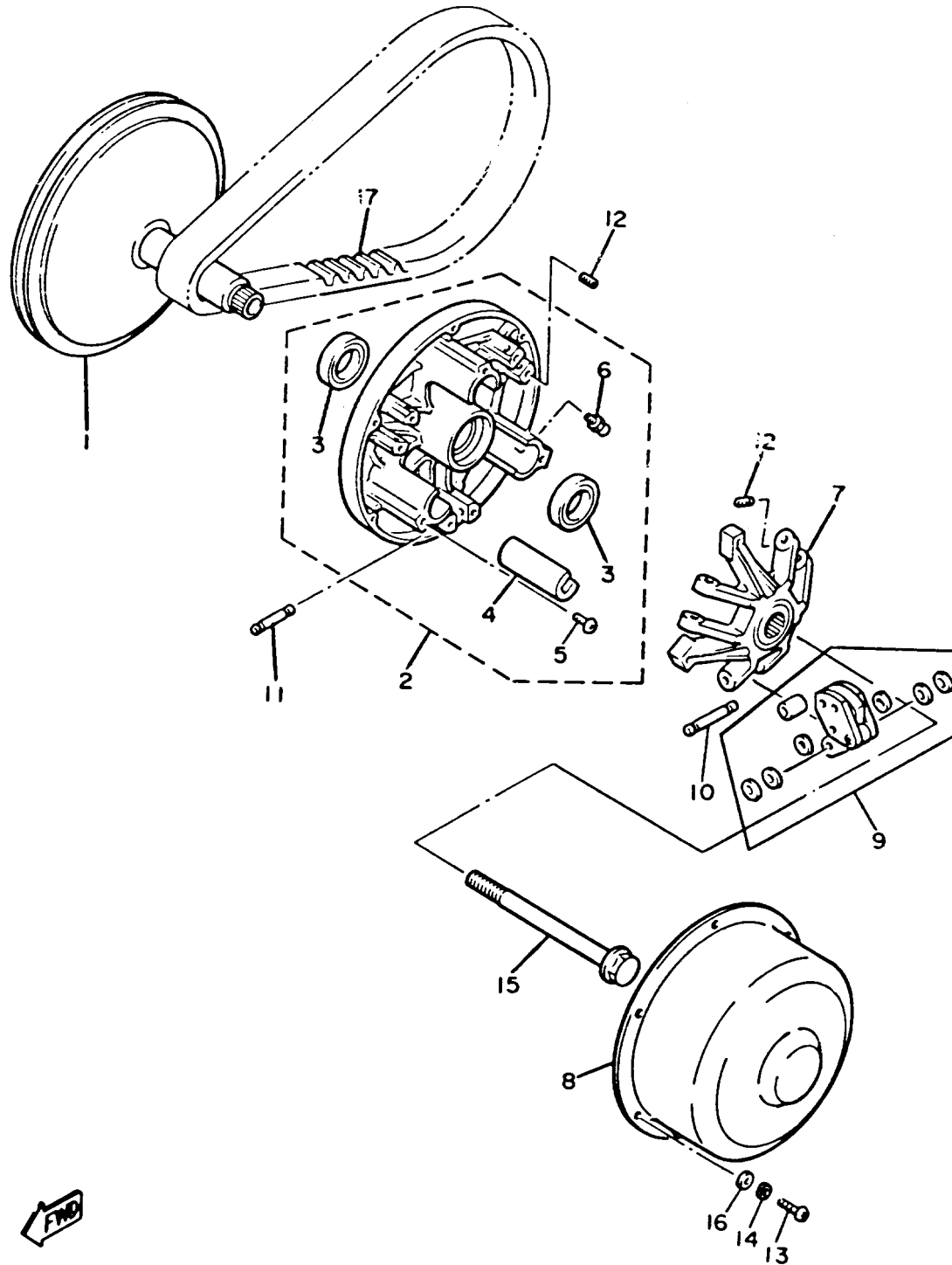

Ref. No.	Part Number	Description	Qty	Remarks
1	J38-46210-00-00	PRIMARY FIXED	1	
2	J38-46220-00-00	PRIMARY SLIDING SHEAVE COMP.	1	
3	93102-28348-00	. OIL SEAL	2	
4	J38-46253-00-00	. SLIDER	3	
5	98901-05008-00	. SCREW, BIND	3	
6	93700-06004-00	. NIPPLE, GREASE	1	
7	J38-46251-00-00	SPIDER	1	
8	J38-46231-00-00	CAP	1	
9	90202-07164-00	. WASHER, PLATE	2	
	90202-07186-00	. WASHER, PLATE	2	
	90387-076U6-00	. COLLAR	1	
	99999-01830-00	WGHT LINK KIT-G2A (J38-46205-00)	3	
	J38-46205-01-00	. WEIGHT LINK ASSEMBLY	1	
10	J38-46236-00-00	. PIN, WEIGHT	3	
11	J38-46237-00-00	. PIN, WEIGHT 2	38	
12	90113-04050-00	BOLT, SET	12	
13	98501-05010-00	SCREW, PAN HEAD	6	
14	92990-05100-00	WASHER, SPRING	6	
15	J38-46249-00-00	BOLT	1	
16	90202-07164-00	WASHER, PLATE	6	
17	J55-G6241-00-00	BELT	1	



J55100-9190

SECONDARY SHEAVE

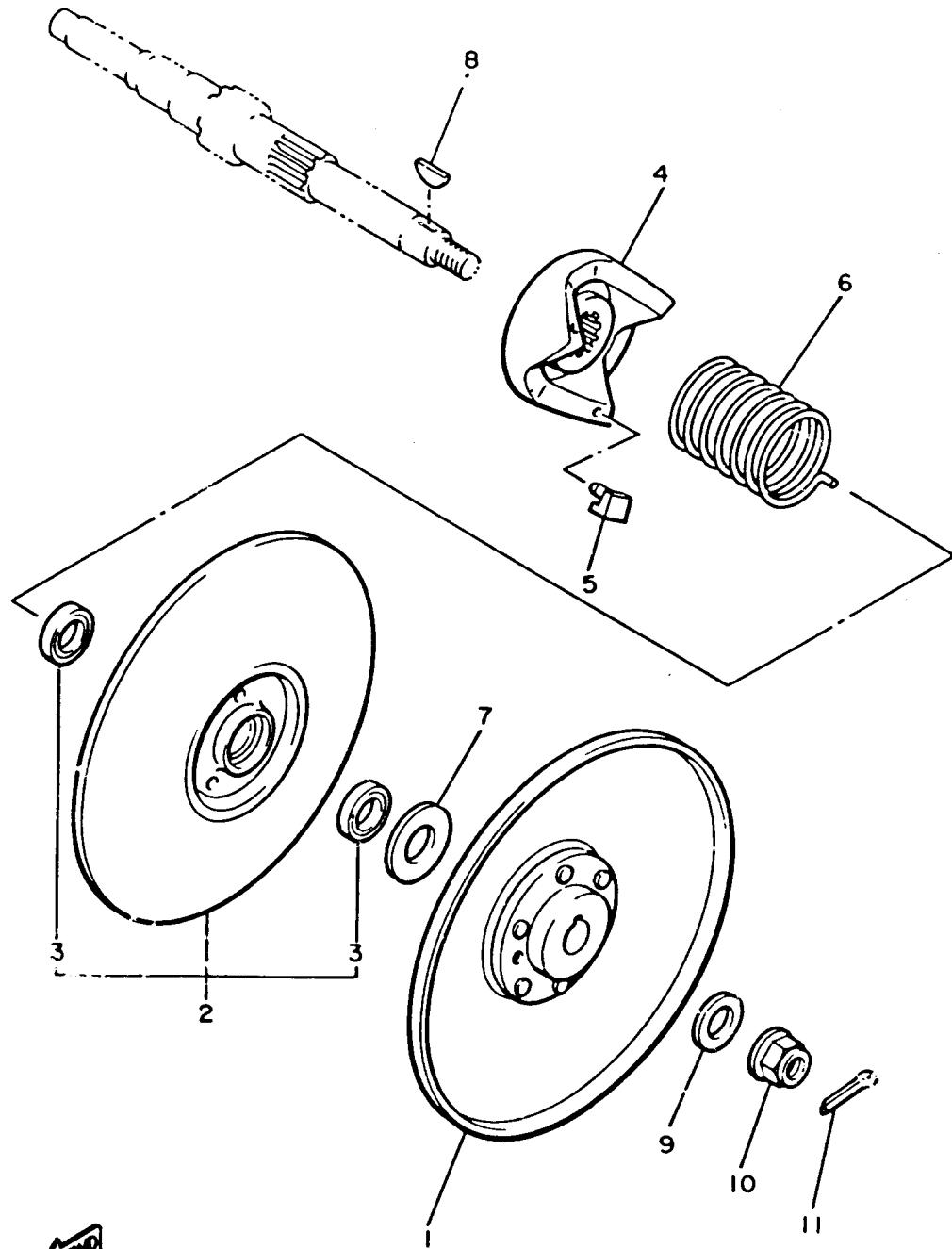

Ref. No.	Part Number	Description	Qty	Remarks
1	J55-G6260-00-00	SECONDARY FIXED SHEAVE COMP.	1	
2	J55-G6270-02-00	SECONDARY SLIDING SHEAVE COMP.	1	
3	93102-20309-00	. SEAL, OIL	2	
4	J38-46284-00-00	SEAT, SEC SPRING	1	
5	801-17688-10-00	SHOE, RAMP	3	
6	90508-45679-00	SPRING, TORSION	1	
7	90202-20130-00	WASHER, PLAIN	1	
8	90280-05022-00	KEY, WOODRUFF	1	
9	90201-12588-00	WASHER, PLATE	1	
10	95601-12200-00	NUT, SELF-LOCKING	1	
11	91401-25030-00	PIN, COTTER	1	



J39700-6200

TRANSMISSION

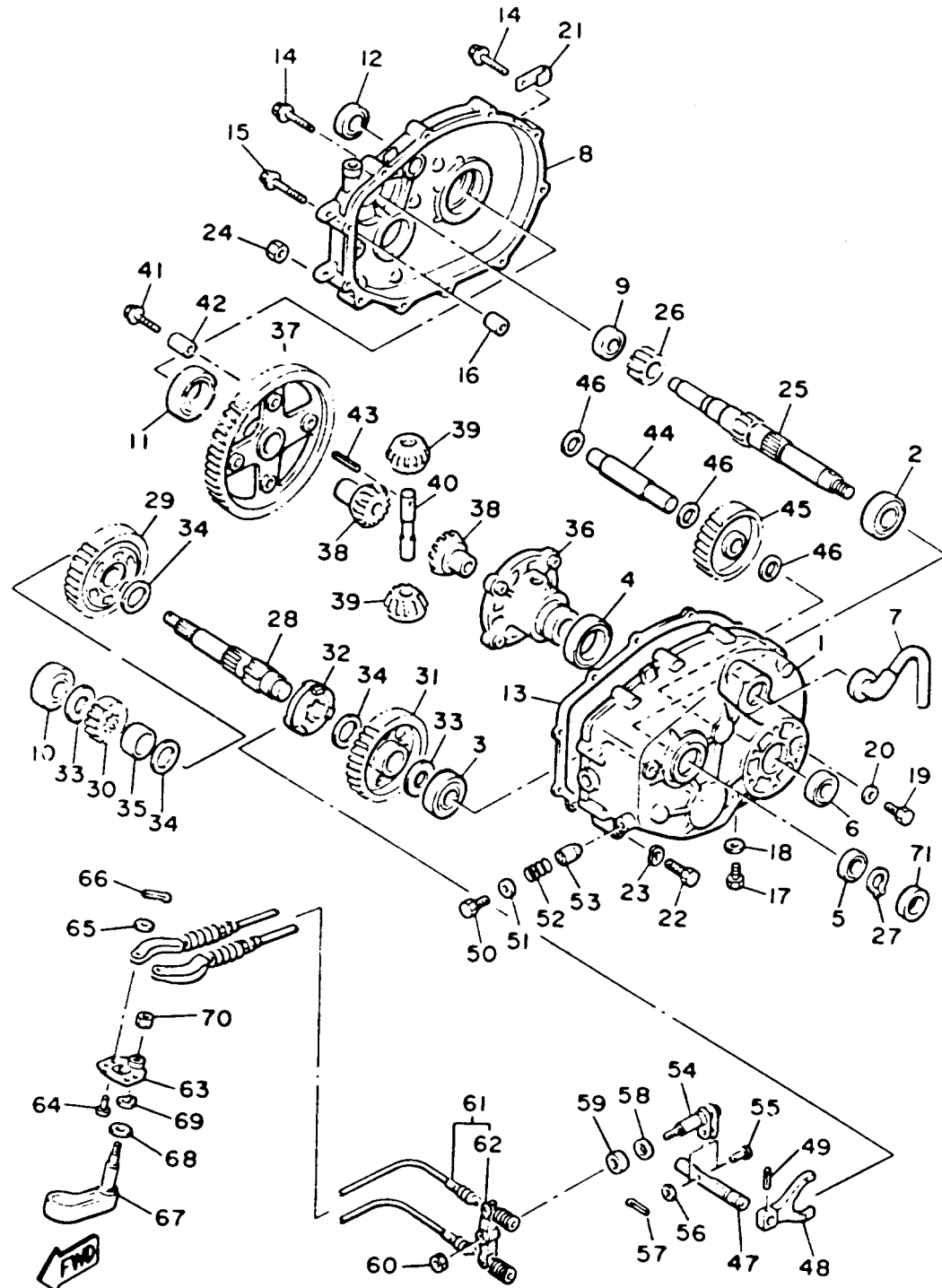

J55100-9211

Ref. No.	Part Number	Description	Qty	Remarks
1	J38-46311-00-00	CASE, TRANSMISSION 1	1	
2	93306-20541-00	BEARING (B6205)	1	
3	93306-20421-00	BEARING	1	
4	93306-00803-00	BEARING (B6008)	1	
5	93102-25017-00	OIL SEAL	1	
6	93102-22189-00	OIL SEAL	1	
7	835-47559-00-00	CAP 2	1	
8	J38-46312-00-00	CASE, TRANS 2	1	
9	93306-20324-00	BEARING	1	
10	93306-20421-00	BEARING	1	
11	93306-00803-00	BEARING (B6008)	1	
12	93102-22189-00	OIL SEAL	1	
13	J38-46319-01-00	GASKET	1	
14	95811-08040-00	BOLT, FLANGE	8	
15	95811-08050-00	BOLT, FLANGE (95812-08050)	2	
16	99510-12016-00	PIN, DOWEL	2	
17	90340-14036-00	PLUG, STRAIGHT SCRW	1	
18	90430-14043-00	GASKET	1	
19	90101-08344-00	BOLT	1	
20	90201-08087-00	WASHER, PLATE	1	
21	90465-06100-00	CLAMP	1	
22	97013-08075-00	BOLT	1	
23	92990-08100-00	WASHER	1	
24	95303-08600-00	NUT	1	
25	J38-46321-02-00	SHAFT, INPUT	1	
26	J38-46331-01-00	GEAR, INPUT 1	1	
27	93410-25017-00	CIRCLIP	1	
28	J38-46351-00-00	SHAFT, COUNTER	1	
29	J38-46361-01-00	GEAR, COUNTER 1	1	

CONTINUED ON NEXT FRAME ➤

TRANSMISSION

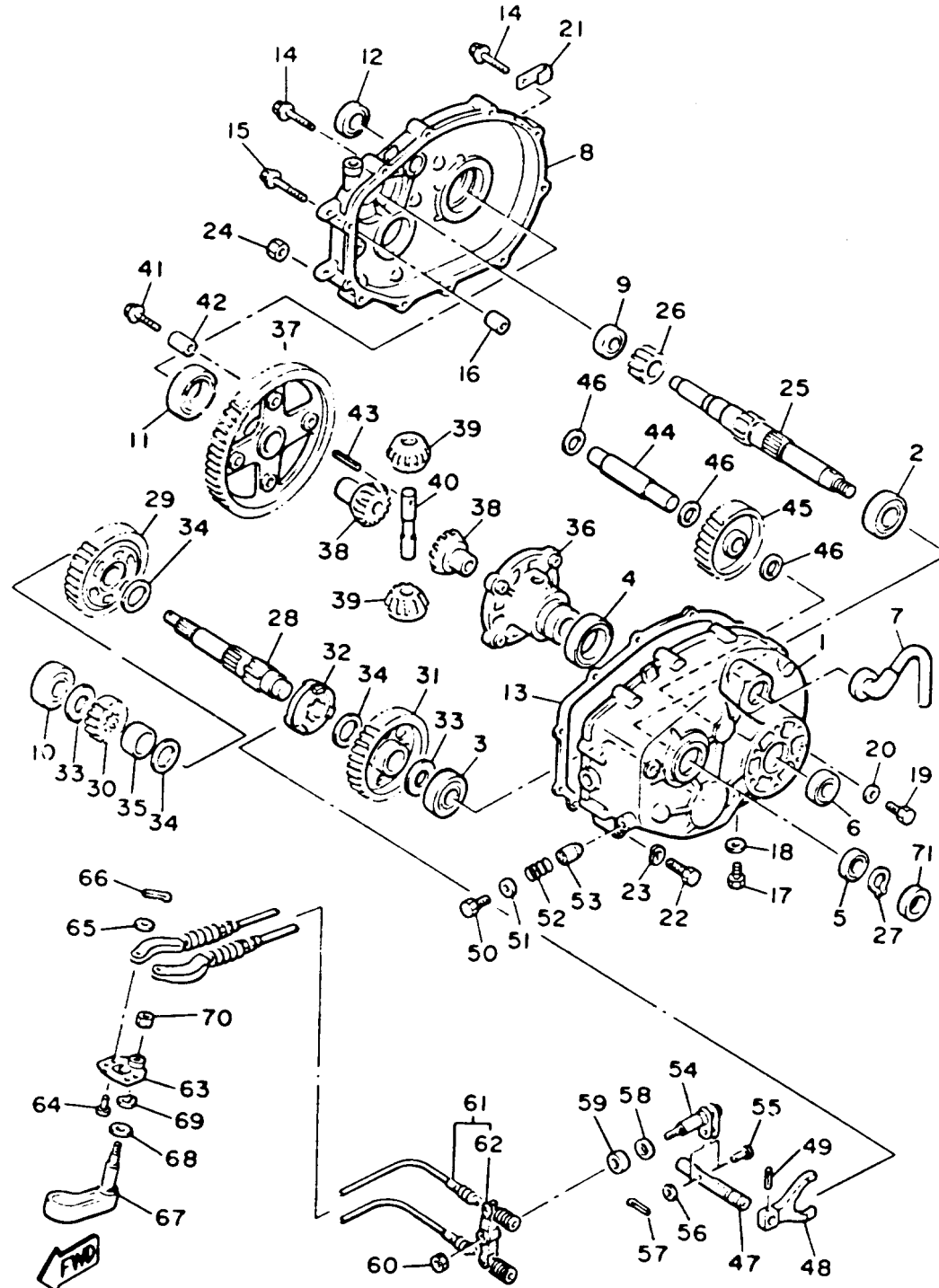

J55100-9211

Ref. No.	Part Number	Description	Qty	Remarks
30	J38-46362-00-00	GEAR, COUNTER 2	1	
31	J38-46363-00-00	GEAR, REVERSE	1	
32	J38-4636A-00-00	DOG, CLUTCH	1	
33	90201-204K8-00	WASHER, PLATE	2	
34	90201-257J2-00	WASHER, PLATE	3	
35	90387-252M8-00	COLLAR	1	
36	J38-46411-01-00	CASE, DIFFERENTIAL	1	
55	91701-06022-00	PIN, CLEVIS	1	
56	92990-06200-00	WASHER	1	
57	91490-20020-00	PIN, COTTER	1	
58	90201-12166-00	WASHER, PLATE	1	
59	93102-12224-00	OIL SEAL	1	
60	J55-G6383-00-00	LEVER, SHIFT	1	
61	95611-08100-00	NUT, U	1	
62	J55-G6371-00-00	SHIFT WIRE	2	
63	J38-46382-00-00	LEVER, SHIFT 1	1	
64	91702-06014-00	PIN	2	
65	92990-06600-00	WASHER, PLATE	2	
66	91490-20020-00	PIN, COTTER	2	
67	J38-46381-00-00	KNOB, SHIFT	1	
68	90201-12474-00	WASHER, PLATE	1	
69	99001-08600-00	CIRCLIP	1	
70	95611-08100-00	NUT, U	1	
71	J55-46322-09-00	SPACER, INPUT SHAFT	1	AP

REAR AXLE - WHEEL

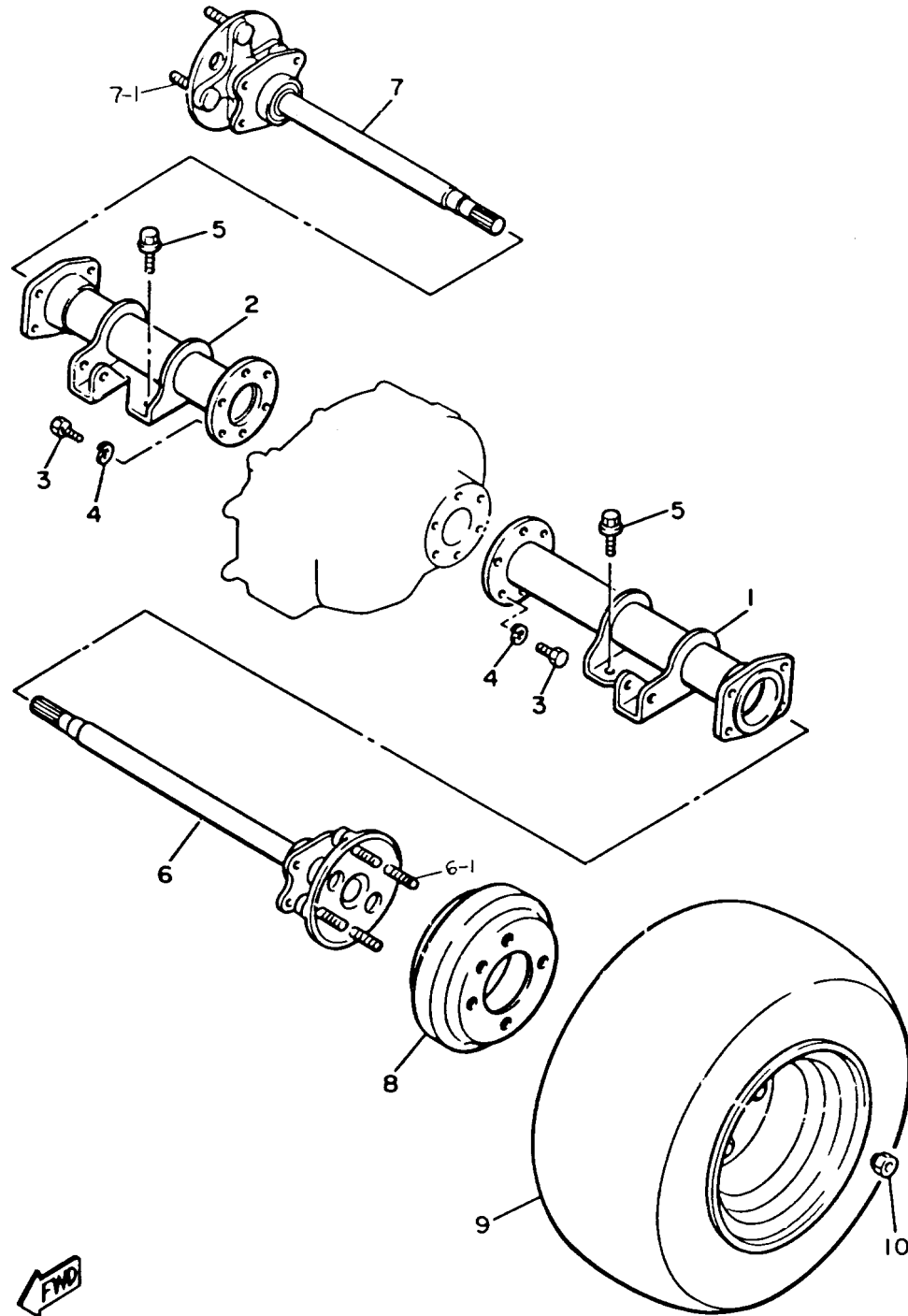

J38100-7220

Ref. No.	Part Number	Description	Qty	Remarks
1	J38-46540-01-00	REAR AXLE HOUSING COMP.	1	
	J55-K8162-00-00	PAD, FRONT BUMPER	1	
2	J38-46550-01-00	REAR AXLE HOUSING	1	
3	97312-08025-00	BOLT (97012-08025)	12	
4	92990-08100-00	WASHER	12	
5	95811-10020-00	BOLT, FLANGE (95822-10020-00)	8	
6	J38-46510-00-00	REAR AXLE SHAFT COMP. ...	1	
7	J38-46520-00-00	REAR AXLE SHAFT COMP. 2 .	1	
8	J55-G6521-00-00	DRUM	2	
9	J55-F5100-00-00	FRONT WHEEL ASSEMBLY ..	2	
10	90179-12262-00	NUT	8	
6-1	90114-12004-00	. BOLT, RIBBED NECK	4	
7-1	90114-12004-00	. BOLT, RIBBED NECK	4	

BODY

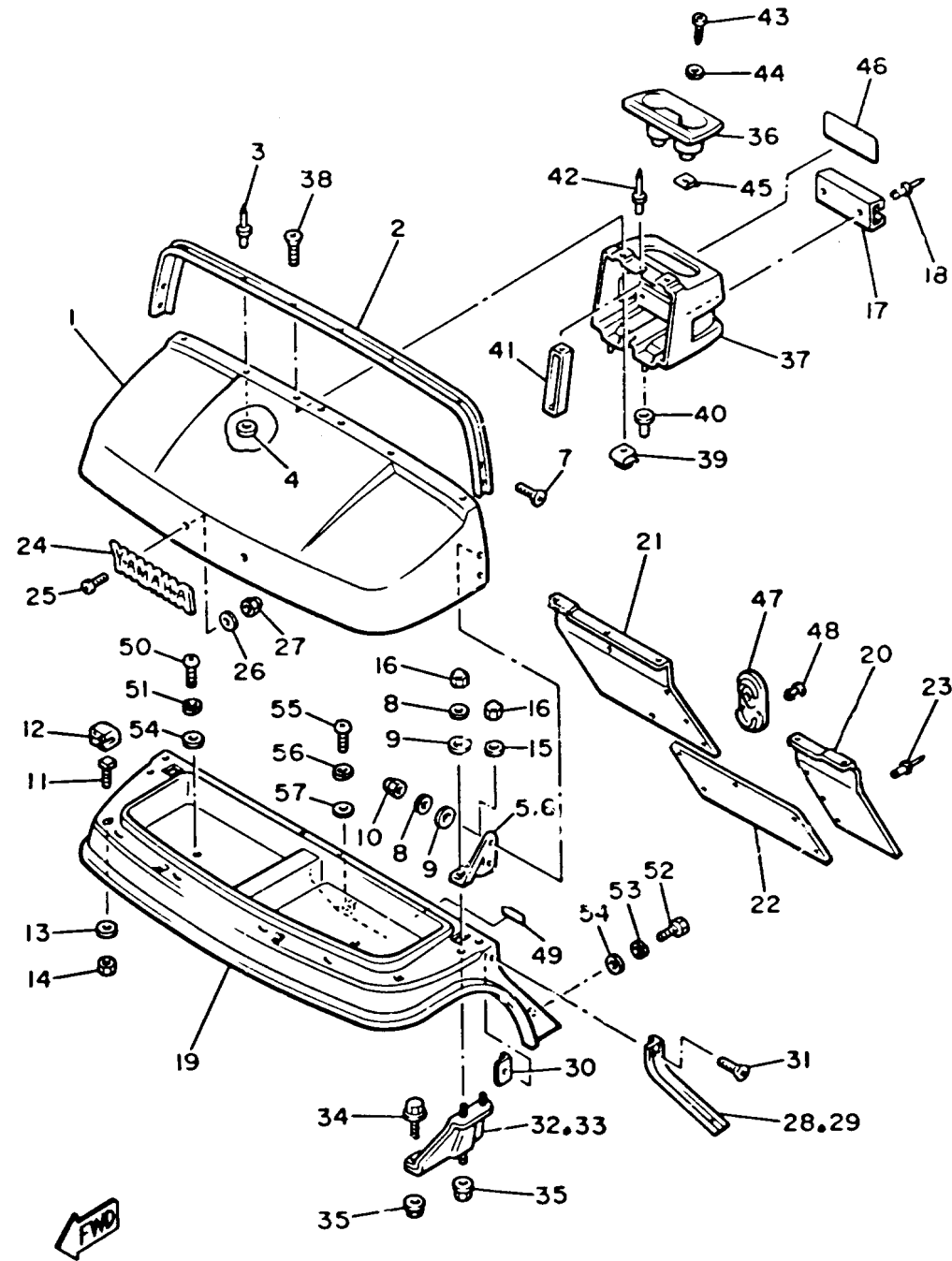

J38100-7240

Ref. No.	Part Number	Description	Qty	Remarks
1	J55-K8116-00-00	COWL, FRONT UPPER	1	
2	J38-7811A-01-00	TRIM, UPPER COWL	1	
3	90267-48051-00	RIVET, BLIND	4	
4	90201-046J3-00	WASHER, PLATE	4	
5	J55-K811E-00-00	STAY, UPPER COWL (L.H) (J38-7811E-01)	1	
6	J55-K811F-00-00	STAY, UPPER COWL (R.H) (J38-7811F-01)	1	
7	90151-06039-00	SCREW, COUNTERSUNK	4	
8	92990-06200-00	WASHER	6	
9	90202-06172-00	WASHER, PLATE	6	
10	95380-06800-00	NUT	4	
11	J38-7811G-00-00	BOLT, COWL FITTING	4	
12	J38-7811H-00-00	RETAINER, COWL FITTING	4	
13	90201-065F3-00	WASHER, PLATE	4	
14	95601-06100-00	NUT, U	4	
15	90201-062G3-00	WASHER, PLATE	2	
16	95380-06800-00	NUT	4	
17	J55-K835A-00-00	HOLDER, BALL	1	
18	90267-63047-00	RIVET, BLIND	2	
19	J55-K8115-01-00	COWL, FRONT (J38-78115-02)	1	
20	J55-K8231-00-00	MAT, MAIN FLOOR 1 (J38-78231-01)	1	
21	J55-K8232-00-00	MAT, MAIN FLOOR 2 (J38-78232-01)	1	
22	J55-K8236-00-00	MAT, PEDAL FLOOR (J38-78236-01)	1	
23	90267-63047-00	RIVET, BLIND	16	
24	J38-24161-00-00	EMBLEM 1	1	
25	90152-04015-00	SCREW, COUNTERSUNK	2	

CONTINUED ON NEXT FRAME ➤

BODY

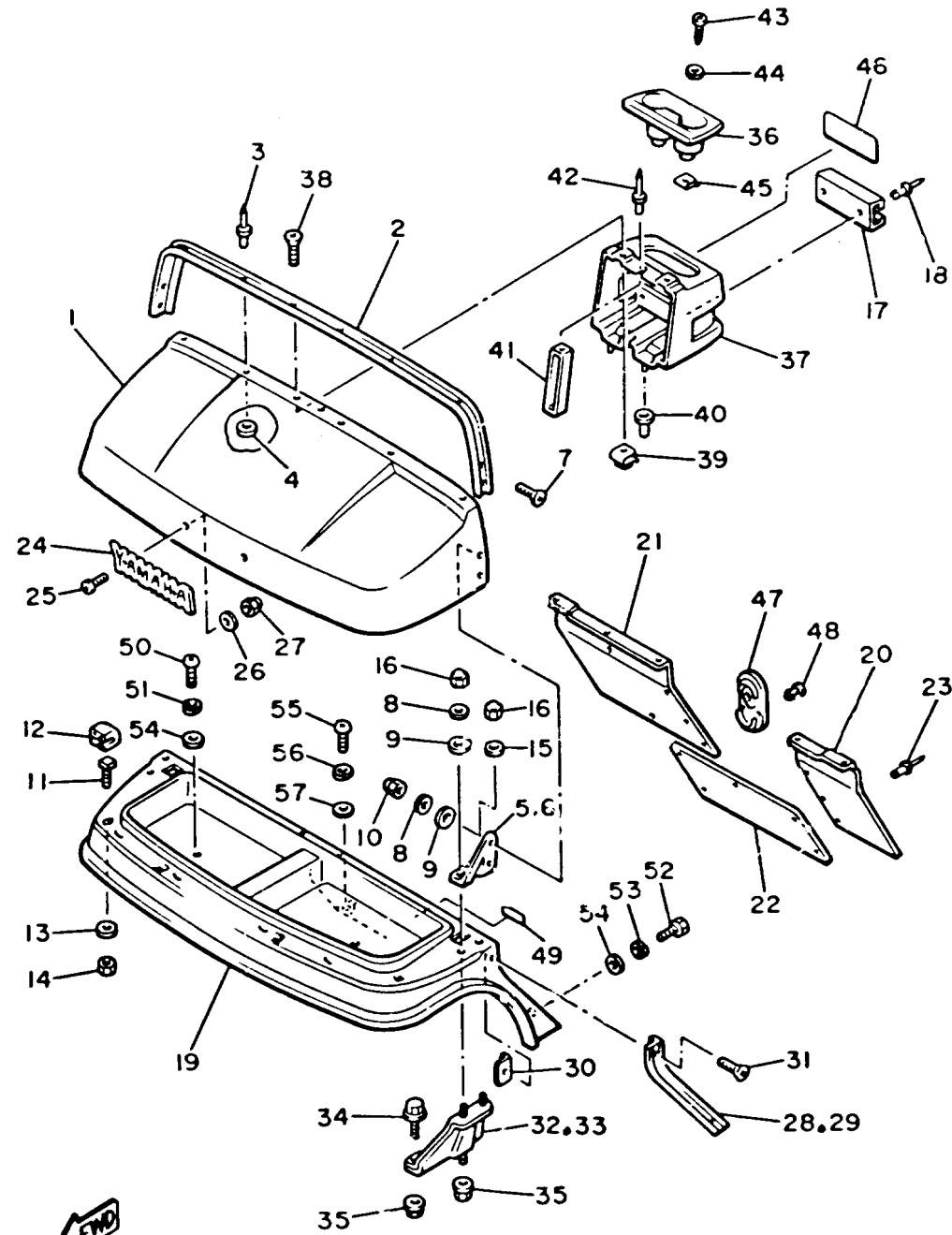

J38100-7240

Ref. No.	Part Number	Description	Qty	Remarks
26	92906-04200-00	WASHER, PLAIN	2	
27	95606-04100-00	NUT, U	2	
28	J38-7811L-00-00	TRIM, COWL SIDE (L.H)	1	
29	J38-7811M-00-00	TRIM, COWL SIDE (R.H)	1	
30	J38-7811K-00-00	NUT, TRIM FITTING	4	
31	90151-06039-00	SCREW, COUNTERSUNK	4	
32	J38-7812E-01-00	SUPPORT, UPPER COWL (L.H)	1	
33	J38-7812F-01-00	SUPPORT, UPPER COWL (R.H)	1	
34	95811-08016-00	BOLT, FLANGE	2	
35	95701-08500-00	NUT, FLANGE	4	
36	J55-K835E-00-00	HOLDER, BEVERAGE (J38-7835E-03)	1	
37	J55-K835G-00-00	HOUSING, HOLDER (J38-7835G-01)	1	
38	90151-06040-00	SCREW, COUNTERSUNK	2	
39	J38-78145-00-00	NUT, REAR BODY MOUNTING	2	
40	90480-12355-00	GROMMET	2	
41	J38-7834A-00-00	REINF., HOLDER	1	
42	90267-48086-00	RIVET, BLIND	2	
43	97780-50125-00	SCREW, TAPPING	2	
44	90201-05556-00	WASHER, PLATE	2	
45	90183-05001-00	NUT, SPRING	2	
46	J55-77768-10-00	LABEL, WARNING (J38-77768-10)	1	U.R.
47	J38-78273-00-00	COVER, HOLE	1	
48	90269-11042-00	RIVET	2	
49	J38-77767-10-00	LABEL, WARNING 7	1	U.R.
50	92580-06020-00	SCREW, PAN HEAD	2	
51	92995-06100-00	WASHER, SPRING	2	
52	97395-06020-00	BOLT, HEXAGON	2	

CONTINUED ON NEXT FRAME ►

BODY

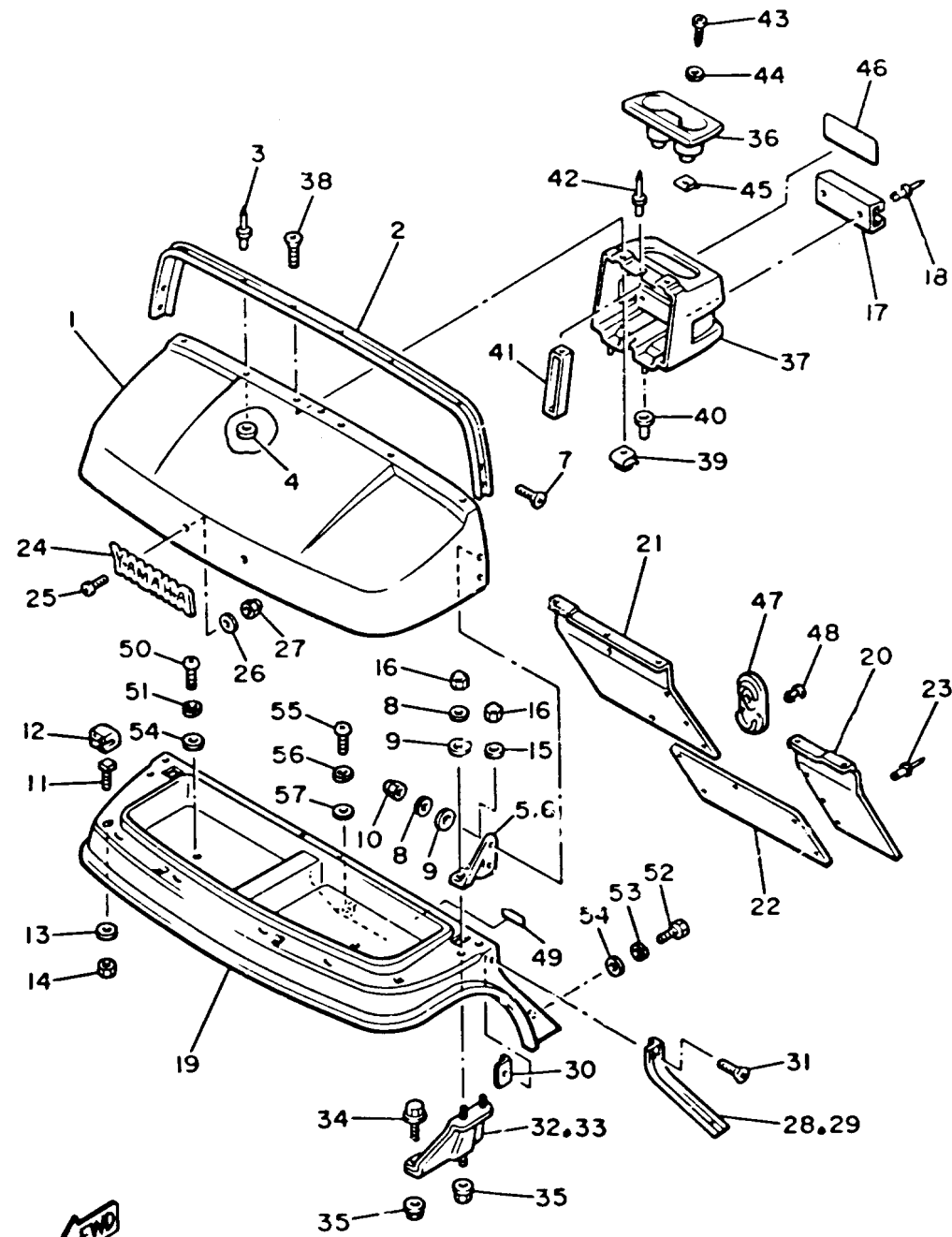

J38100-7240

Ref. No.	Part Number	Description	Qty	Remarks
53	92995-06100-00	WASHER, SPRING	2	
54	90201-06697-00	WASHER, PLATE	4	
55	92580-06020-00	SCREW, PAN HEAD	1	
56	92995-06100-00	WASHER, SPRING	1	
57	90201-06049-00	WASHER, PLATE	1	

BODY 2

Ref. No.	Part Number	Description	Qty	Remarks
1	J55-K8141-00-00	PANEL, INTERMEDIATE BODY	1	
2	J38-7814N-00-00	PLATE, ORNAMENT	1	
3	90267-40131-00	RIVET, BLIND	7	
4	J41-77458-10-00	LABEL, WARNING (J41-77458-00-00)	1	U.R.
5	J38-77741-10-00	INDICATOR 1	1	U.R.
6	J38-77742-00-00	INDICATOR 2	1	
7	J55-K8121-00-00	REINFORCEMENT 1	1	
8	98980-06016-00	SCREW, BINDING	4	
9	90201-06697-00	WASHER, PLATE	4	
10	J38-7814F-00-00	SEAL, BODY SIDE 2	2	
11	J38-7815A-00-00	PLATE, SEAL SUPPORT 1	2	
12	90267-40054-00	RIVET, BLIND	12	
13	90338-06169-00	PLUG	2	
14	90183-06011-00	NUT, SPRING	2	
15	J55-K8143-00-00	HINGE, INTERMEDIATE BODY 1	2	
16	J55-K8144-00-00	HINGE, INTERMEDIATE BODY 2	2	
17	91790-06125-00	PIN, CLEVIS	2	
18	91490-20015-00	PIN, COTTER	2	
19	97003-06012-00	BOLT (97001-06012)	4	
20	92995-06100-00	WASHER, SPRING	4	
21	92990-06600-00	WASHER, PLATE	4	
22	97023-06020-00	BOLT (3XF)	4	
23	92995-06100-00	WASHER, SPRING	4	
24	92990-06600-00	WASHER, PLATE	4	
25	J55-K8251-00-00	PAD, SILENCER 1	1	
26	J55-K8252-00-00	PAD, SILENCER 2	1	
27	J55-K8253-00-00	PAD, SILENCER 3	1	

CONTINUED ON NEXT FRAME ►

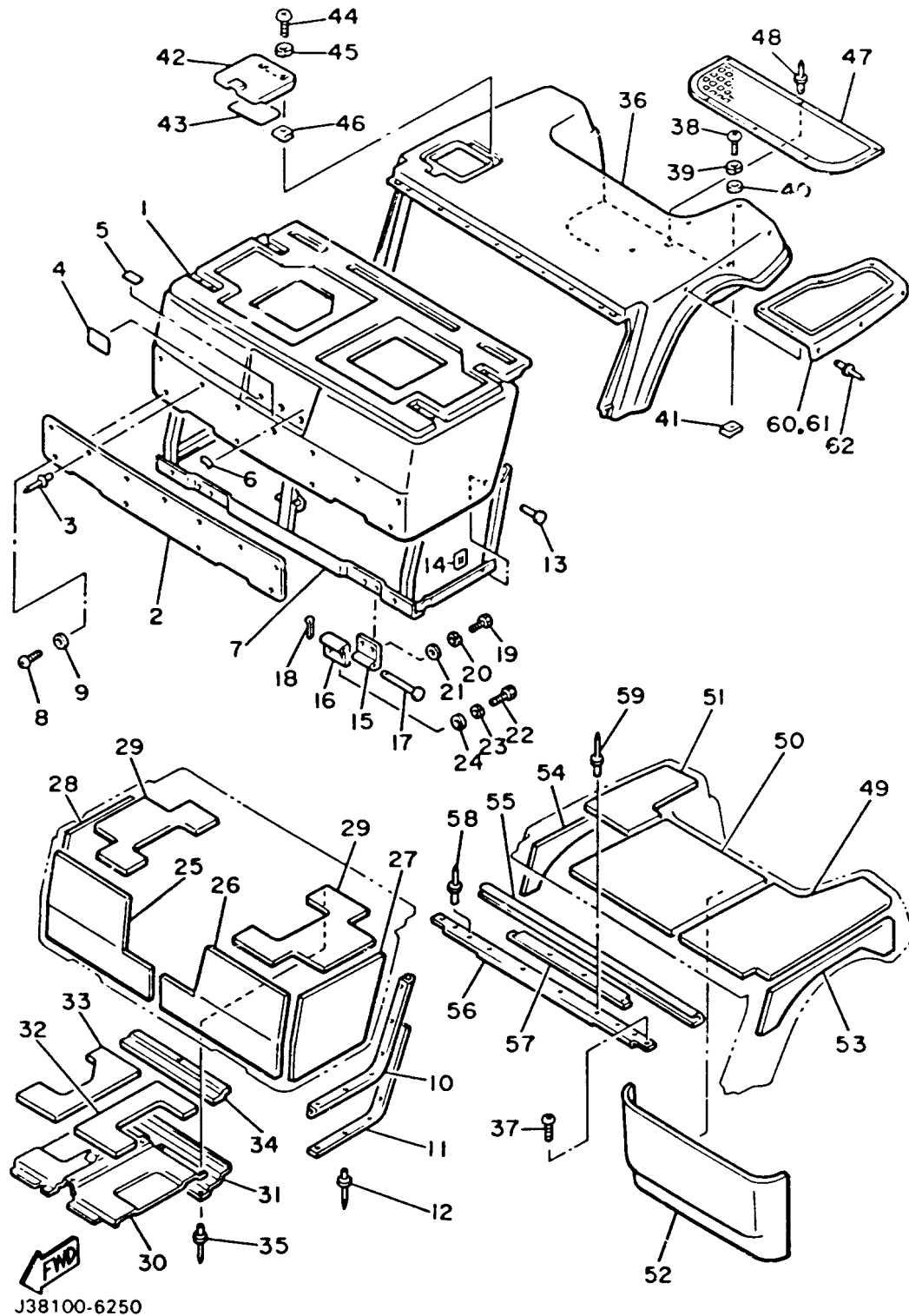

J38100-6250

BODY 2

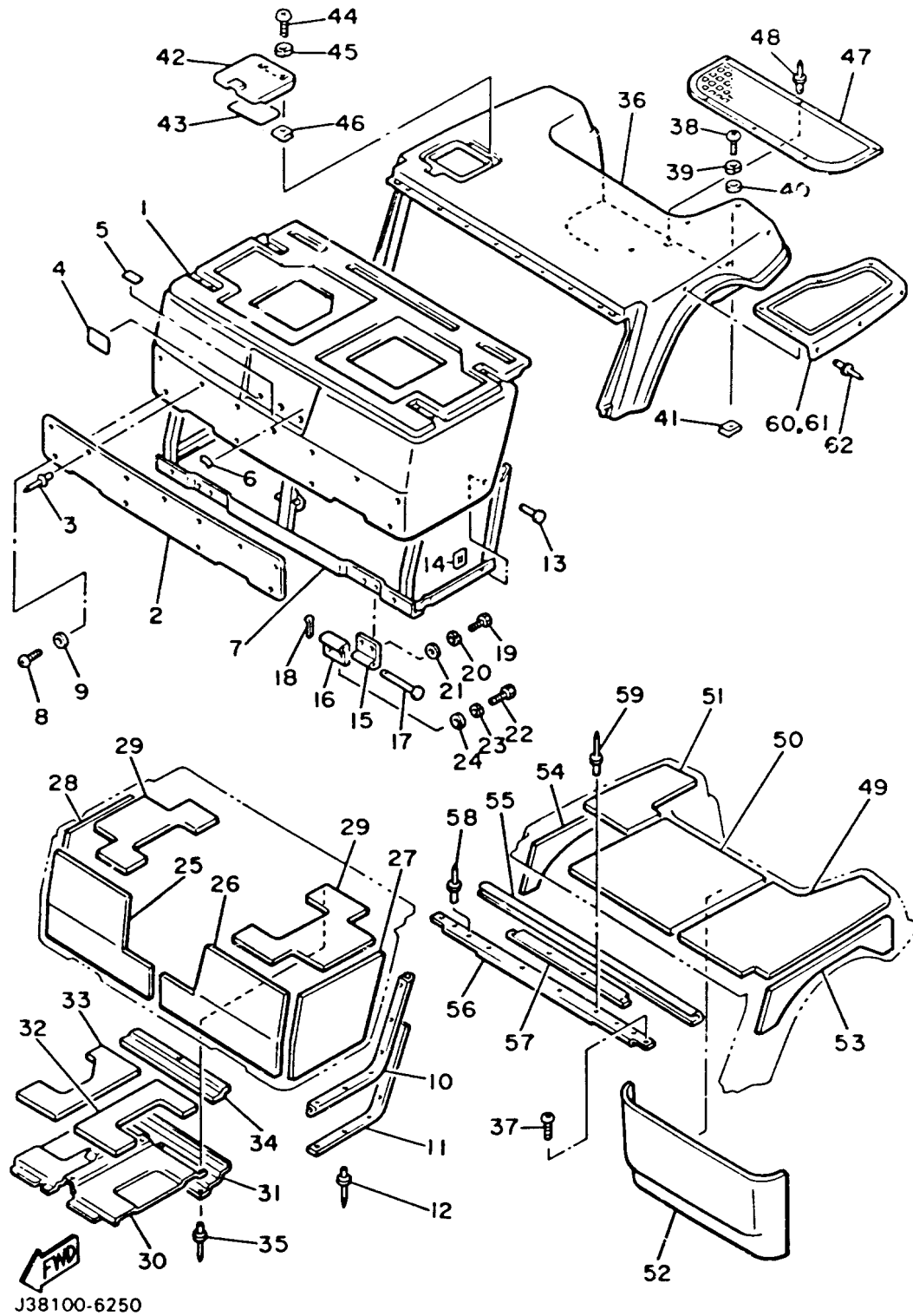

J38100-6250

Ref. No.	Part Number	Description	Qty	Remarks
28	J55-K8254-00-00	PAD, SILENCER 4	1	
29	J55-K825K-00-00	PAD, SILENCER 6	1	
30	J55-K8261-00-00	PLATE, BODY PROTECT 1	1	
31	J55-K8262-00-00	PLATE, BODY PROTECT 2	1	
32	J55-K826A-00-00	PAD, BODY PROTECT 1	1	
33	J55-K826E-00-00	PAD, BODY PROTECT 2	1	
34	J55-K826F-00-00	PAD, BODY PROTECT 3	1	
35	90267-40054-00	RIVET, BLIND	10	
36	J55-K8142-00-00	PANEL, REAR BODY	1	
37	98902-06025-00	SCREW, BIND	3	
38	92580-06020-00	SCREW, PAN HEAD	2	
39	92995-06100-00	WASHER, SPRING	2	
40	90201-065F3-00	WASHER, PLATE	2	
41	90183-06028-00	NUT, SPRING	2	
42	J55-K8272-00-00	COVER, FUEL INLET	1	
43	J38-77764-10-00	LABEL, WARNING 4	1	U.R.
44	98511-04012-00	SCREW, PAN HEAD	2	
45	92901-04100-00	WASHER, SPRING	2	
46	J38-78276-00-00	NUT, INLET FITTING	2	
47	J55-K8241-00-00	MAT, REAR FLOOR (J38-78241-00)	1	
48	90267-63047-00	RIVET, BLIND	6	
49	J55-K8255-00-00	PAD, SILENCER 5	1	
50	J38-78256-00-00	PAD, SILENCER 6	1	
51	J55-K8257-00-00	PAD, SILENCER 7	1	
52	J55-K8258-00-00	PAD, SILENCER 8	1	
53	J55-K825L-00-00	PAD, SILENCER 17 (J38-7825L-00)	1	
54	J55-K825J-00-00	PAD, SILENCER 15 (J38-7825J-00)	1	

CONTINUED ON NEXT FRAME ►

BODY 2

Ref. No.	Part Number	Description	Qty	Remarks
55	J38-7814A-00-00	SEAL, BODY UPPER	1	
56	J55-K815F-00-00	PLATE, SEAL SUPPORT 3	1	
57	J38-7826G-00-00	PAD, BODY PROTECT 4	1	
58	90267-40077-00	RIVET, BLIND	4	
59	90267-40129-00	RIVET, BLIND	3	
60	J55-K8243-00-00	MAT, REAR BODY SIDE (LH)	1	
61	J55-K8244-00-00	MAT, REAR BODY SIDE (RH)	1	
62	90267-63047-00	RIVET, BLIND	12	

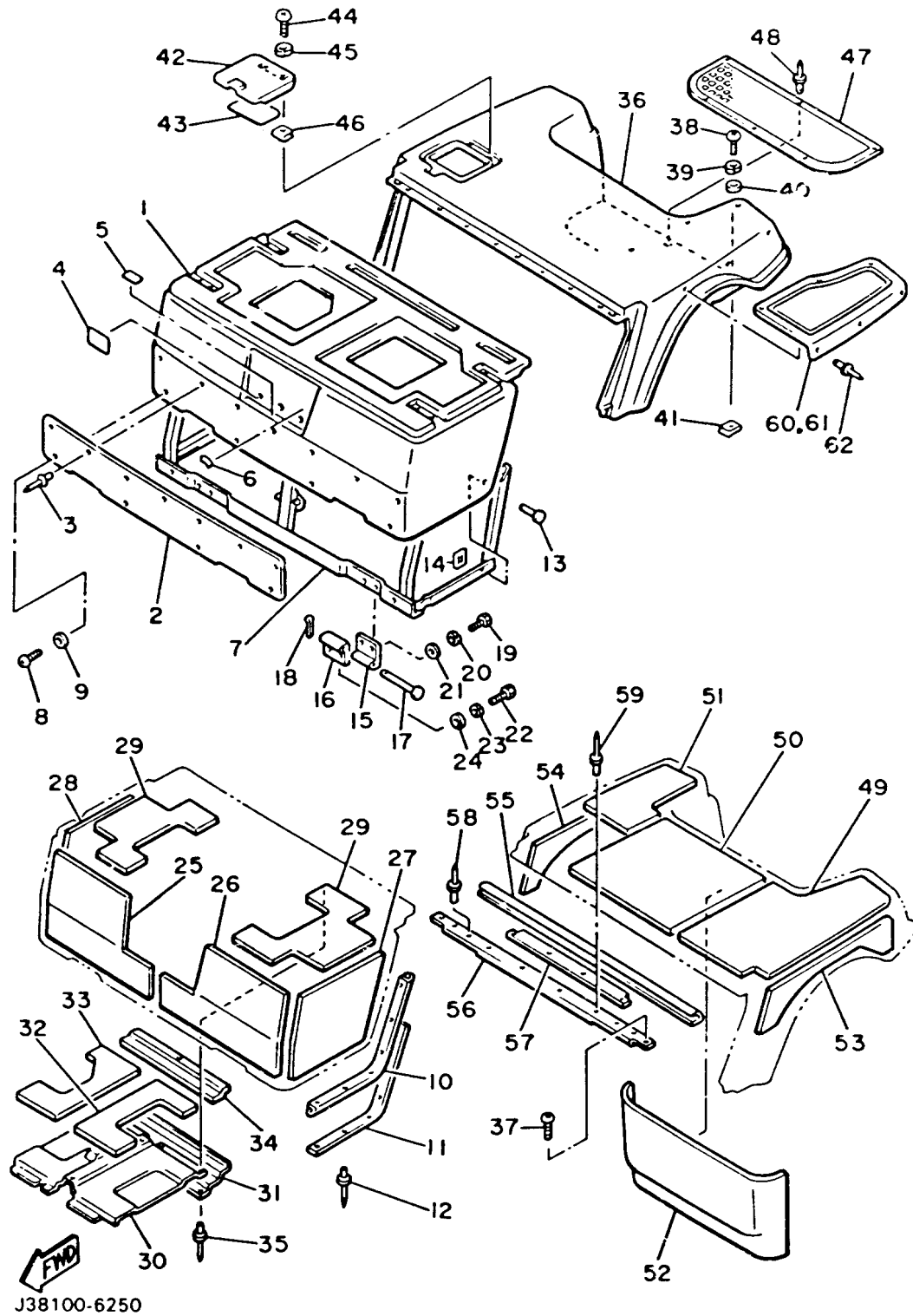

BODY FITTING

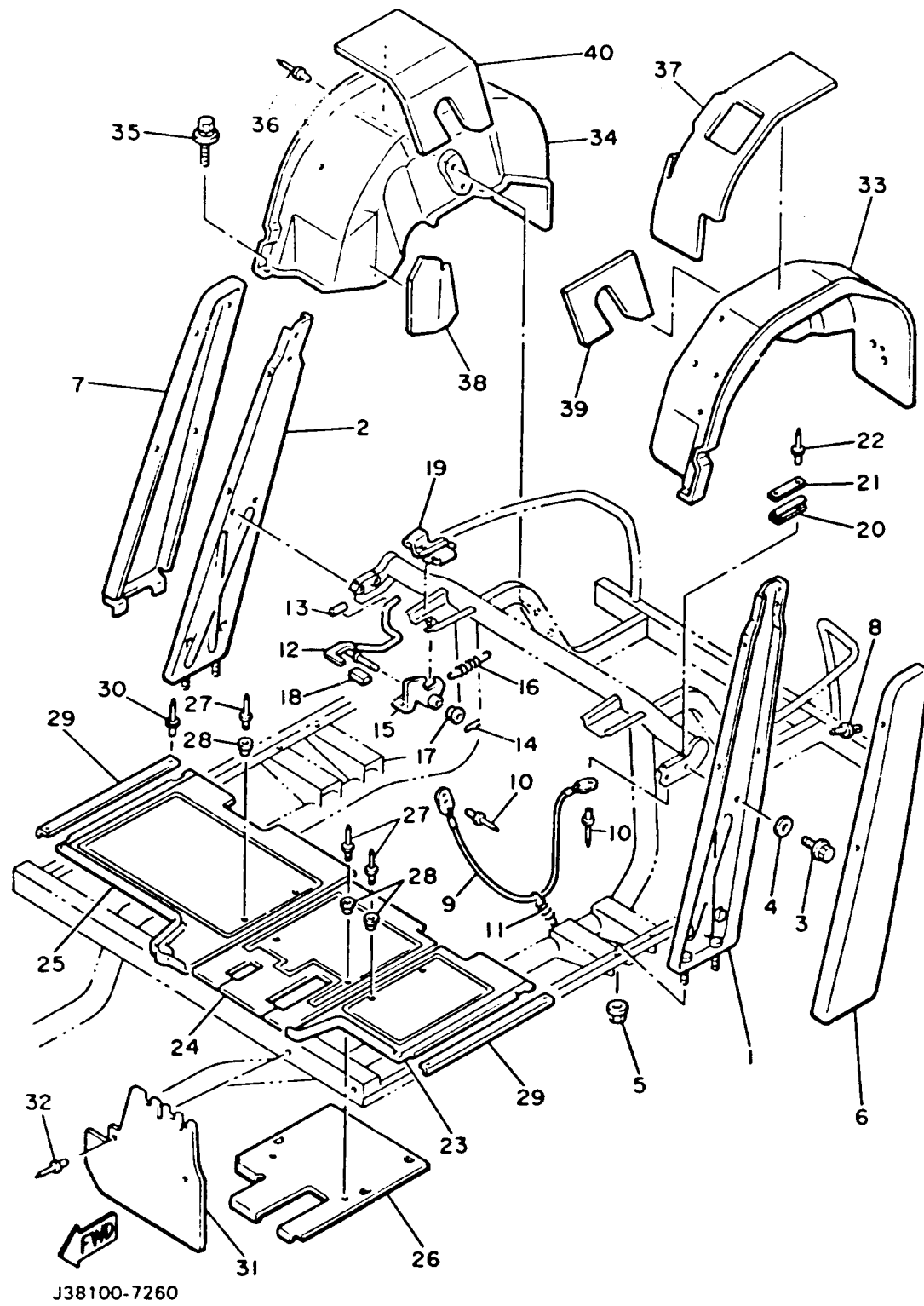

Ref. No.	Part Number	Description	Qty	Remarks
1	J55-K813A-00-00	PILLAR, SIDE (L.H) (J38-7813A-01)	1	
2	J55-K813E-00-00	PILLAR, SIDE R (J38-7813E-01)	1	
3	95811-08016-00	BOLT, FLANGE	4	
4	90201-08730-00	WASHER, PLATE	4	
5	95701-06500-00	NUT, FLANGE	4	
6	J55-K813F-00-00	COVER, SIDE PILLAR (L.H)	1	
7	J55-K813G-00-00	COVER, SIDE PILLAR (R.H)	1	
8	90267-63134-00	RIVET, BLIND	8	
9	J39-78229-00-00	WIRE, SEAT STOPPER	1	
10	90267-40087-00	RIVET, BLIND	2	
11	90507-08037-00	SPRING, TENSION	1	
12	J38-7814G-01-00	LEVER, BODY LOCK	1	
13	90445-11147-00	HOSE	1	
14	90468-18008-00	CLIP	1	
15	J38-7814H-01-00	HOOK, BODY LOCK	1	
16	90506-18374-00	SPRING, TENSION	1	
17	J38-7814L-01-00	BUSH, LEVER END	2	
18	J38-7815H-00-00	DAMPER, LOCK	1	
19	J38-78221-00-00	SHEET, BODY MOUNTING 1	2	
20	J38-7814E-00-00	SEAL, BODY SIDE 1	2	
21	J38-7815E-00-00	PLATE, SEAL SUPPORT 2	2	
22	90267-40054-00	RIVET, BLIND	4	
23	J38-78203-00-00	FLOOR MAT COMP. 3	1	
24	J55-K8234-00-00	MAT, MAIN FLOOR 4	1	
25	J38-78205-00-00	FLOOR MAT COMP. 5	1	
26	J55-K8271-00-00	SERVICE LID, PEDAL	1	
27	90267-48086-00	RIVET, BLIND	6	
28	90387-081R2-00	COLLAR	6	

CONTINUED ON NEXT FRAME ►

BODY FITTING

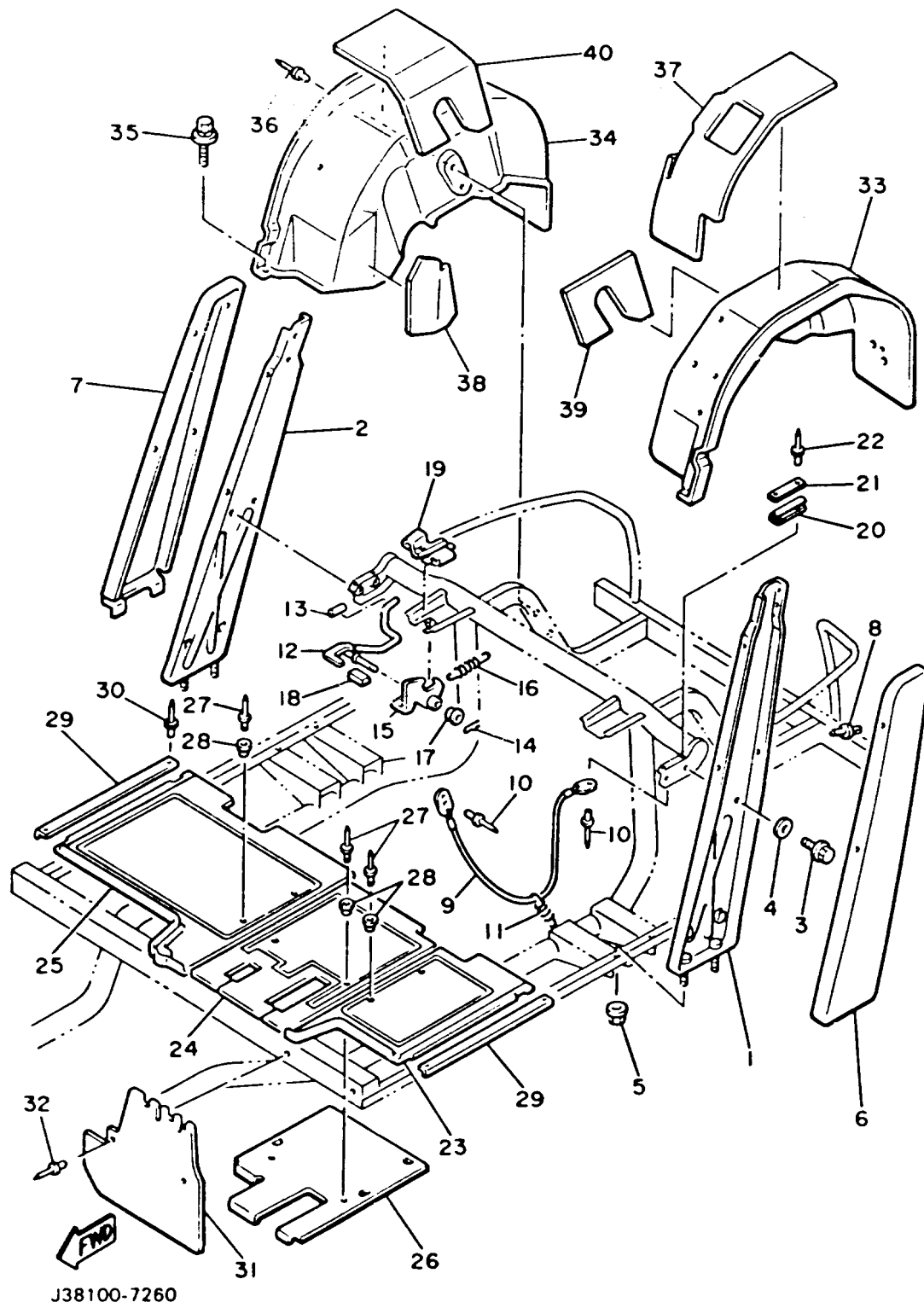

Ref. No.	Part Number	Description	Qty	Remarks
29	J38-78215-00-00	PLATE, SIDE TRIM	2	
30	90267-40115-00	RIVET, BLIND	4	
31	J55-K8187-00-00	FLAP, FRONT FENDER (J38-78187-01)	2	
32	90267-48101-00	RIVET, BLIND	4	
33	J55-K8191-00-00	PANEL, REAR FENDE 1	1	
34	J55-K8192-00-00	PANEL, REAR FENDER 2	1	
35	90119-06108-00	BOLT, WITH WASHER	2	
36	90267-48101-00	RIVET, BLIND	6	
37	J55-K8259-00-00	PAD, SILENCER 9 (J38-78259-00)	1	
38	J55-K825A-00-00	PAD, SILENCER 10 (J38-7825A-00)	1	
39	J55-K825F-00-00	PAD, silencer 12 (J38-7825F-00)	1	
40	J55-K825G-00-00	PAD, SILENCER 13 (J38-7825G-00)	1	

CARRIER

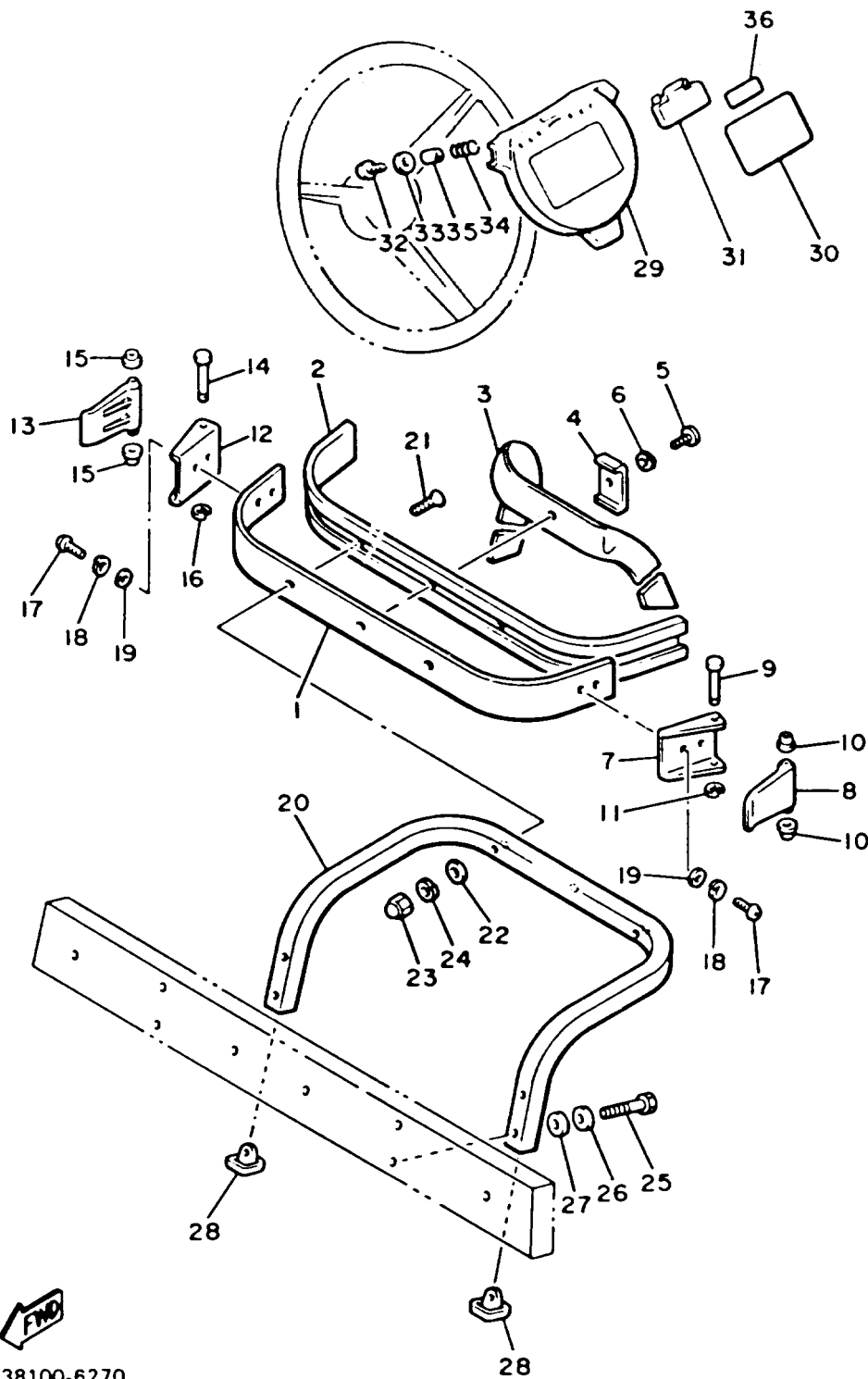

J38100-6270

Ref. No.	Part Number	Description	Qty	Remarks
1	J55-K8351-00-00	SUPPORT, BAG UPPER (J38-78351-00)	1	
2	J38-78356-00-00	PAD, BAG SUPPORT	1	
3	J38-78355-00-00	BAND	1	
4	J38-78367-00-00	PLATE, ANCHOR	1	
5	98980-06016-00	SCREW, BINDING	1	
6	92995-06100-00	WASHER, SPRING	1	
7	J17-78157-01-00	BASE, LOCK	1	
8	J17-78368-01-00	LEVER, LOCK	1	
9	J17-78369-00-00	PIN, LEVER	1	
10	90386-06108-00	BUSH	2	
11	99080-05600-00	CIRCLIP	1	
12	J17-78157-01-00	BASE, LOCK	1	
13	J17-78368-01-00	LEVER, LOCK	1	
14	J17-78369-00-00	PIN, LEVER	1	
15	90386-06108-00	BUSH	2	
16	99080-05600-00	CIRCLIP	1	
17	98580-06010-00	SCREW, PAN HEAD (92503-06010)	4	
18	92995-06100-00	WASHER, SPRING	4	
19	92990-06200-00	WASHER	4	
20	J55-K8352-00-00	SUPPORT, BAG LOWER 1 (J38-78352-01)	1	
21	98701-08040-00	SCREW, FLAT HEAD (92701-08040)	2	
22	90202-08022-00	WASHER, PLATE	2	
23	95380-08800-00	NUT, CROWN	2	
24	92990-08100-00	WASHER	2	
25	90101-08649-00	BOLT	4	
26	90202-08022-00	WASHER, PLATE	4	

CONTINUED ON NEXT FRAME ►

CARRIER

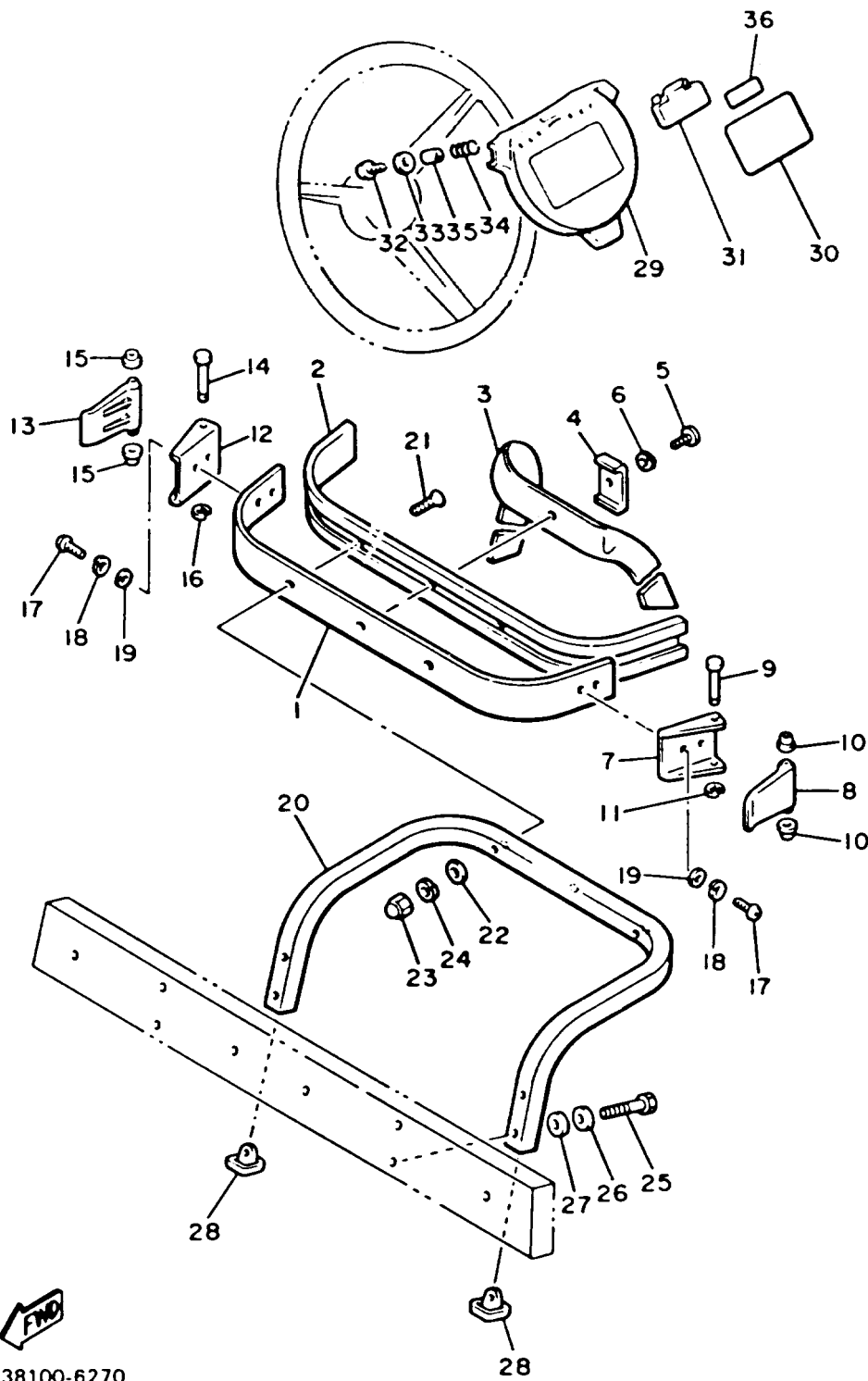

J38100-6270

Ref. No.	Part Number	Description	Qty	Remarks
27	90202-08171-00	WASHER, PLATE	6	
28	J38-7835H-00-00	CAP, BAG SUPPORT LOWER .	2	
29	J55-K8357-00-00	HOLDER 1	1	
30	J55-77762-10-00	LABEL, WARNING 2 (J38-77762-01)	1	U.R.
31	J55-K8358-00-00	HOLDER 2	1	
32	97706-40525-00	SCREW, TAPPING	2	
33	90201-044H9-00	WASHER, PLAIN	2	
34	90502-10013-00	SPRING, CONICAL	2	
35	90387-046N7-00	COLLAR	2	
36	J38-77763-10-00	LABEL, WARNING 3	1	U.R.

SEAT

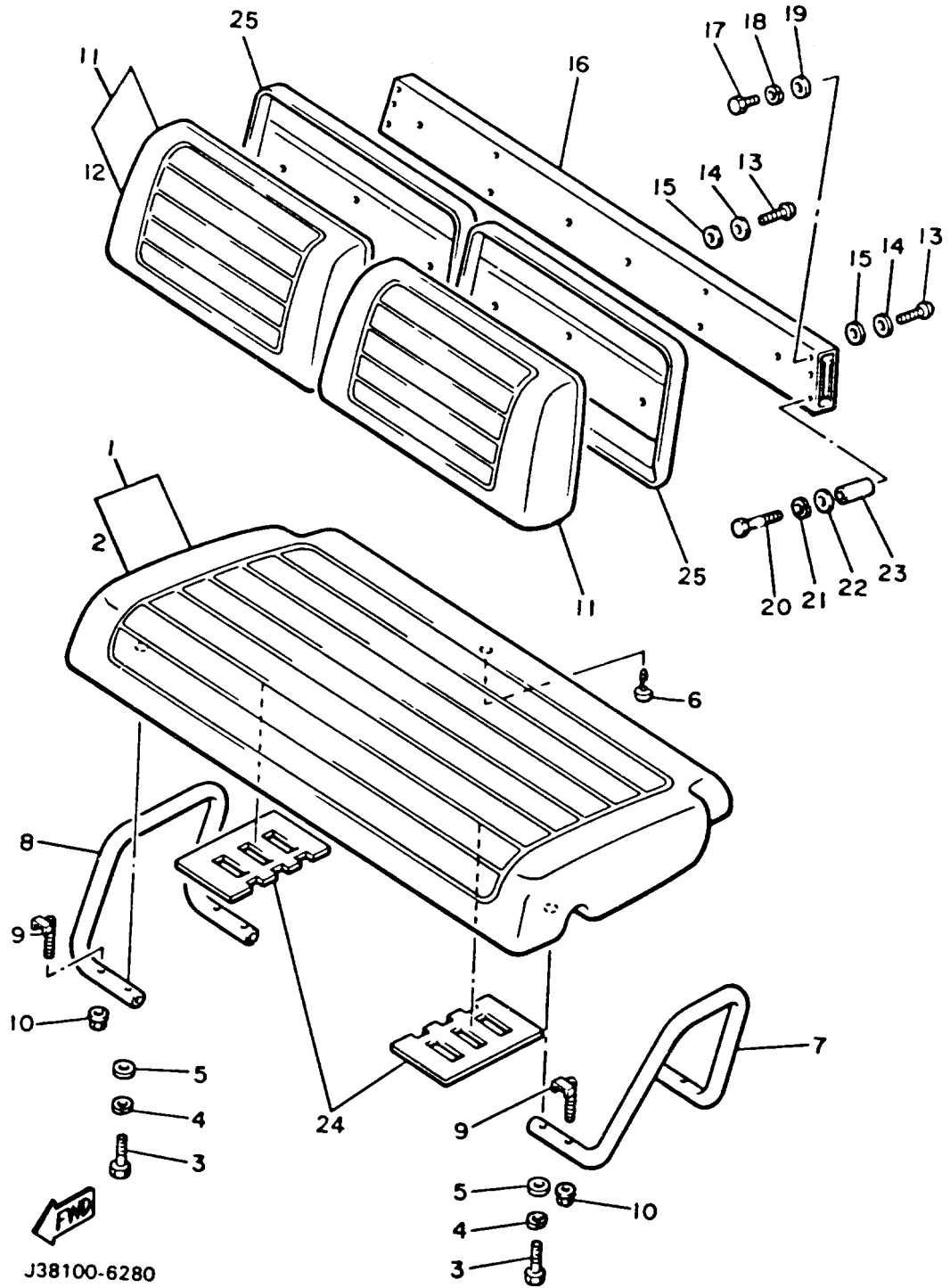

Ref. No.	Part Number	Description	Qty	Remarks
1	J55-K8401-00-00	SEAT SUB ASS'Y CUSHION (J38-78401-02)	1	
2	J55-K8404-09-00	. SEAT COVER	1	
3	97021-08065-00	BOLT	4	
4	92990-08100-00	WASHER	4	
5	92990-08600-00	WASHER, PLATE	4	
6	97780-50116-00	SCREW, TAPPING (97780-50516)	1	
7	J38-78361-00-00	ARM REST 1	1	
8	J38-78362-00-00	ARM REST 2	1	
9	J38-78384-00-00	BOLT	4	
10	95601-08200-00	NUT, U	4	
11	J55-K8402-00-00	SEAT SUB ASS'Y, BACK (J38-78402-01)	2	
12	J55-K841G-09-00	. COVER, SEAT BACK 2	2	
13	98980-06045-00	SCREW, BIND	4	
14	90201-065F3-00	WASHER, PLATE	4	
15	90202-06170-00	WASHER, PLATE	4	
16	J55-K8423-09-00	SUPPORT, SEAT BACK (J55-K8423-00)	1	
17	97022-08016-00	BOLT	2	
18	92990-08100-00	WASHER	2	
19	92990-08600-00	WASHER, PLATE	2	
20	97013-08075-00	BOLT	2	
21	92990-08100-00	WASHER	2	
22	92990-08600-00	WASHER, PLATE	2	
23	90387-103G9-00	COLLAR	2	
24	J55-K8419-00-00	PAD, SEAT PROTECTOR	2	
25	J55-K8413-00-00	COVER, SEAT BACK	2	

STARTER MOTOR

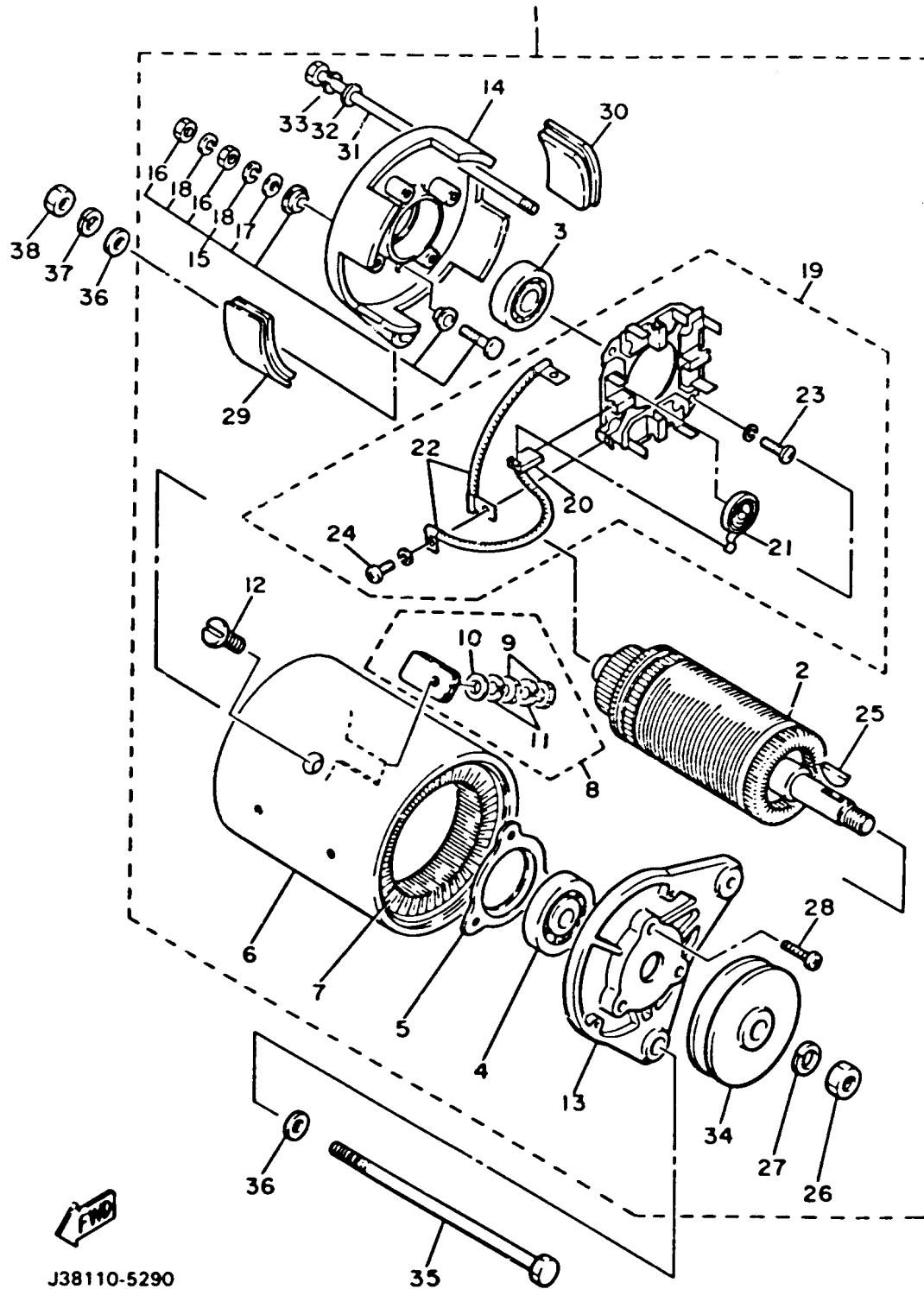

J38110-5290

Ref. No.	Part Number	Description	Qty	Remarks
1	J38-81100-11-00	STARTER GENERATOR ASSEMBLY (JF2-H1100-00-00)	1	
2	J10-81150-10-00	. ARMATURE ASSEMBLY	1	
3	J10-81157-10-00	. BEARING 1 (6202 SD)	1	
4	J10-81158-10-00	. BEARING 2 (6203 SD)	1	
5	J10-81159-10-00	. HOLDER, BEARING	1	
6	J38-81110-10-00	. STATOR ASSEMBLY	1	
7	J38-81160-10-00	. FIELD COIL ASSEMBLY	1	
8	J10-81148-10-00	. SCREW	2	
9	95380-06600-00	.. NUT	4	
10	92990-06600-00	.. WASHER, PLATE	2	
11	92995-06100-00	.. WASHER, SPRING	4	
12	J10-81146-10-00	. SCREW	4	
13	J38-81165-10-00	. BRACKET, STARTER GENERATOR	1	
14	J10-81166-10-00	. BRACKET, STARTER GENERATOR	1	
15	J10-81147-10-00	. SCREW	2	
16	95380-06600-00	.. NUT	4	
17	92990-06600-00	.. WASHER, PLATE	2	
18	92995-06100-00	.. WASHER, SPRING	4	
19	JF2-81119-00-00	. BRUSH HOLDER ASSEMBLY	1	
20	JF2-81111-00-00	.. BRUSH	4	
21	J38-81113-10-00	.. SPRING, BRUSH	4	
22	J10-81115-10-00	.. WIRE, LEAD	2	
23	98580-05016-00	.. SCREW, PAN HEAD	2	
24	98580-04010-00	.. SCREW, PAN HEAD	4	
25	J38-81163-10-00	. KEY	1	
26	95301-14600-00	. NUT	1	
27	92901-14100-00	. WASHER, SPRING	1	

CONTINUED ON NEXT FRAME ►

STARTER MOTOR

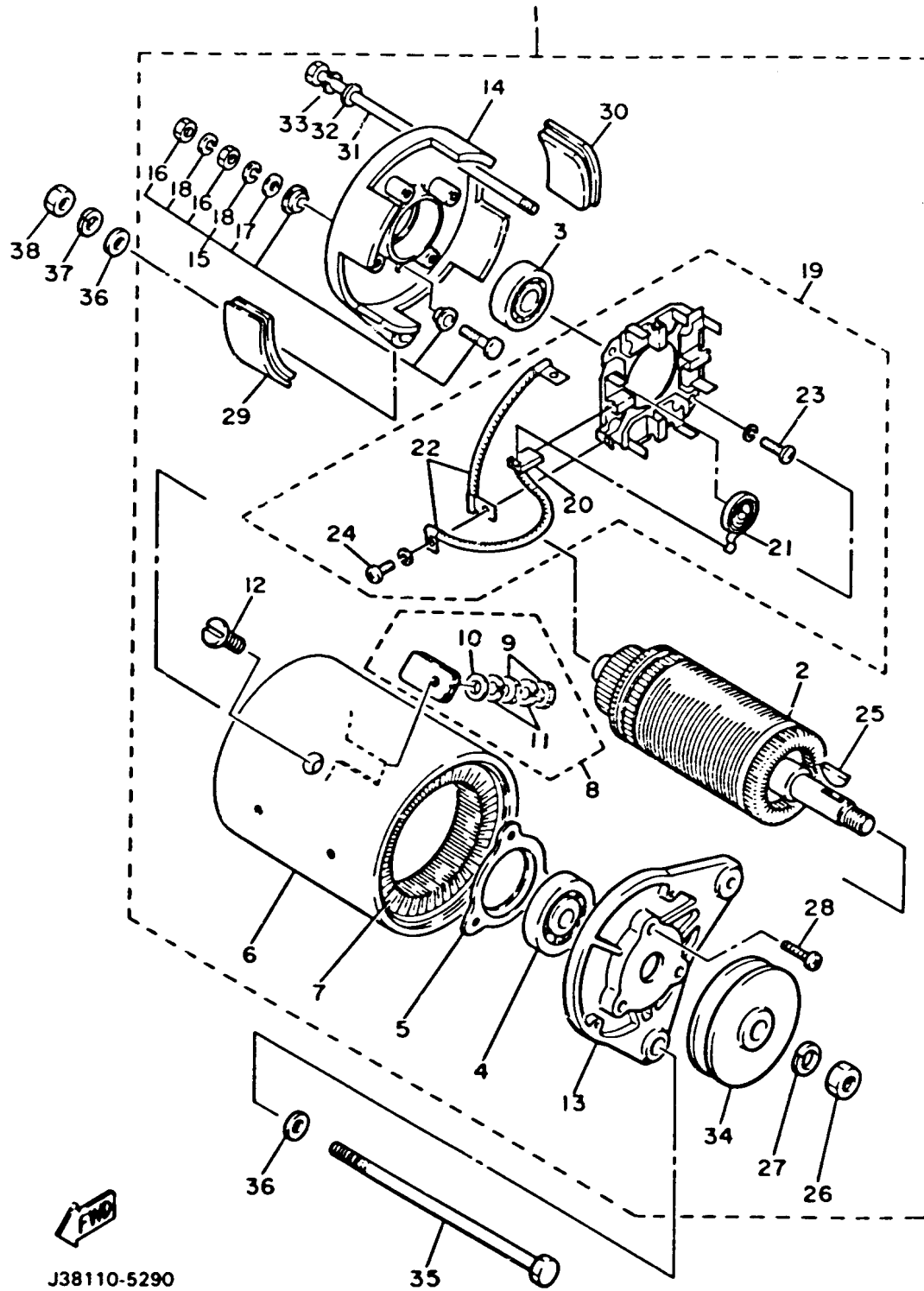

Ref. No.	Part Number	Description	Qty	Remarks
28	98501-05018-00	. SCREW, PAN HEAD	3	
29	J10-81129-10-00	. COVER, BRUSH	3	
30	J10-81129-10-00	. COVER, BRUSH	1	
31	J10-81145-10-00	. SCREW	2	
32	92990-06600-00	. WASHER, PLATE	2	
33	92995-06100-00	. WASHER, SPRING	2	
34	J38-81161-10-00	. PULLEY	1	
35	90101-12545-00	BOLT	1	
36	92990-12600-00	WASHER, PLATE	2	
37	92901-12100-00	WASHER, SPRING	1	
38	95303-12600-00	NUT	1	

ELECTRICAL 1

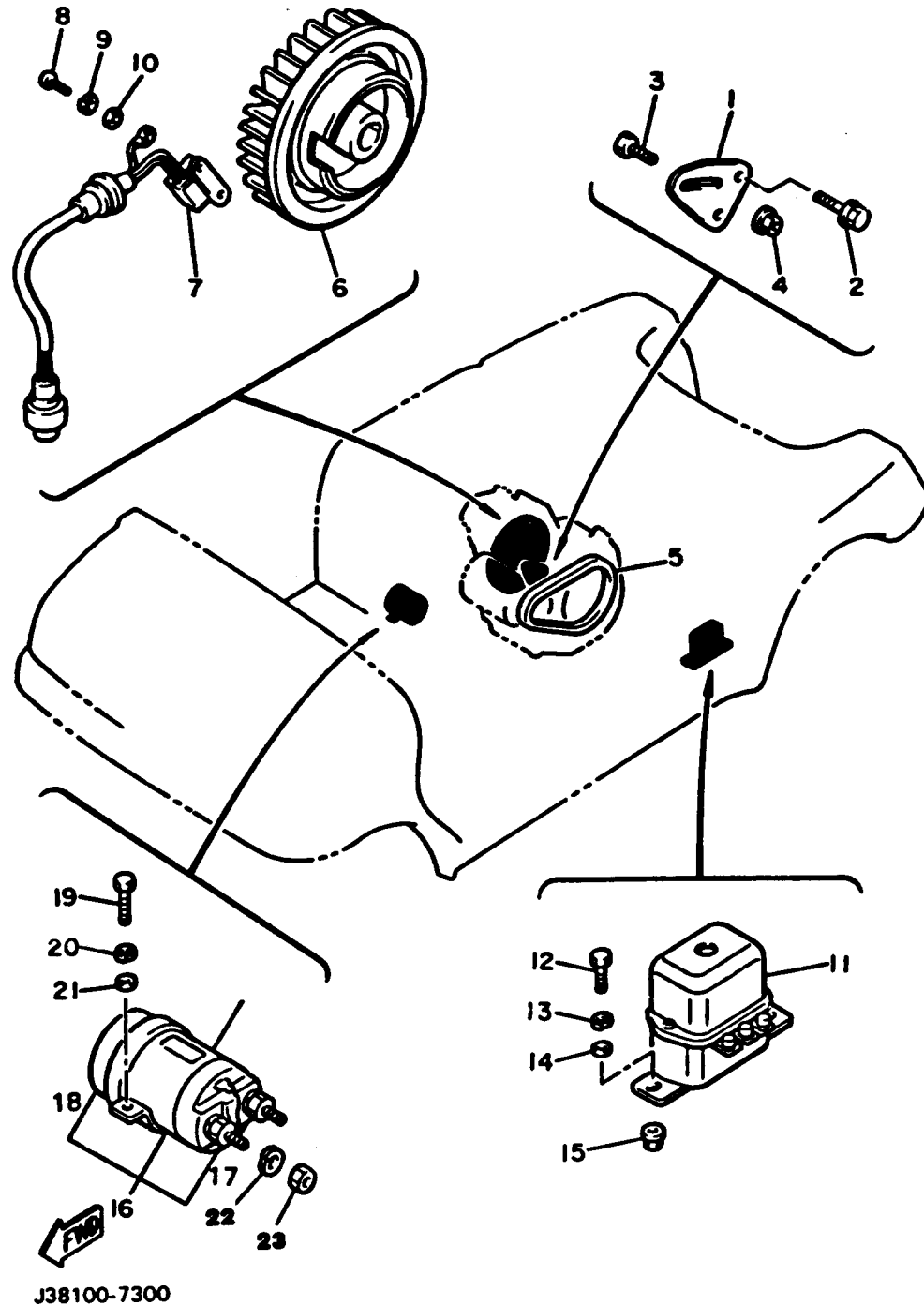

Ref. No.	Part Number	Description	Qty	Remarks
1	J38-81170-00-00	TENSIONER ASSEMBLY	1	
2	95821-08025-00	BOLT, FLANGE	2	
3	90109-087A5-00	BOLT	1	
4	95701-08500-00	NUT, FLANGE	1	
5	J55-H1173-00-00	BELT	1	
6	J38-81350-20-00	ROTOR ASSEMBLY	1	
7	J38-85580-20-00	COIL, PULSER	1	
8	98580-05016-00	SCREW, PAN HEAD	2	
9	92990-05100-00	WASHER, SPRING	2	
10	92901-05600-00	WASHER, PLATE	2	
11	J10-81910-10-00	VOLTAGE REG ASSEMBLY ASS'Y	1	
12	97313-06016-00	BOLT, HEXAGON	2	
13	92995-06100-00	WASHER, SPRING	2	
14	92990-06600-00	WASHER, PLATE	2	
15	95702-06600-00	NUT, FLANGE	2	
16	J38-81950-00-00	RELAY ASS'Y	1	
17	J41-81920-09-00	. G2A/E SLND RBLDKIT	1	
18	J38-8195R-00-00	. RUBBER BOOT	1	
19	97011-06020-00	BOLT	2	
20	92995-06100-00	WASHER, SPRING	2	
21	92990-06600-00	WASHER, PLATE	2	
22	92990-08100-00	WASHER	2	
23	95303-08700-00	NUT	2	

ELECTRICAL 2

Ref. No.	Part Number	Description	Qty	Remarks
1	*---	FRONT WHEEL ASSEMBLY ..	1	LM See Note
2	J55-H2122-00-00	SEAT, BATTERY	1	
3	J17-82133-00-00	SCREW, FITTING	2	
4	J55-H2136-00-00	PLATE, BATTERY	1	
5	92990-06200-00	WASHER	2	
6	95701-06300-00	NUT, NYLON	2	
7	J55-H2115-00-00	WIRE, PLUS LEAD (J38-82115-00)	1	
8	861-82361-00-00	CLAMP, CORD	1	
9	J55-H2116-00-00	WIRE, MINUS LEAD (J38-82116-00)	1	
10	J55-H2117-00-00	WIRE, LEAD	1	
11	J38-82105-00-00	WIRE HARNESS	1	
12	J38-82590-21-00	WIRE HARNESS ASSEMBLY (J38-82590-20)	1	
13	J55-H7196-00-00	TUBE 1 (J38-87196-00)	1	
14	J55-H7197-00-00	TUBE 2 (J38-87197-00)	1	
15	90465-06038-00	CLAMP	2	
16	90464-23041-00	CLAMP	1	
17	J38-82305-20-00	IGNITOR UNIT ASSEMBLY 1 ..	1	
18	J38-8553A-00-00	STAY UNIT	1	
19	95801-06010-00	BOLT, flange	2	
20	J38-82310-20-00	IGNITION COIL ASSEMBLY ...	1	
21	98580-05020-00	SCREW, PAN HEAD	2	
22	92990-05100-00	WASHER, SPRING	2	
23	J38-82318-00-00	WIRE, SUB-LEAD	1	
24	8K1-82370-20-00	PLUG CAP ASSEMBLY (WITH RESISTOR)	1	
25	J38-82372-00-00	SEAL, plug cap	1	
26	1E6-82150-00-00	FUSE HOLDER ASSEMBLY ...	1	

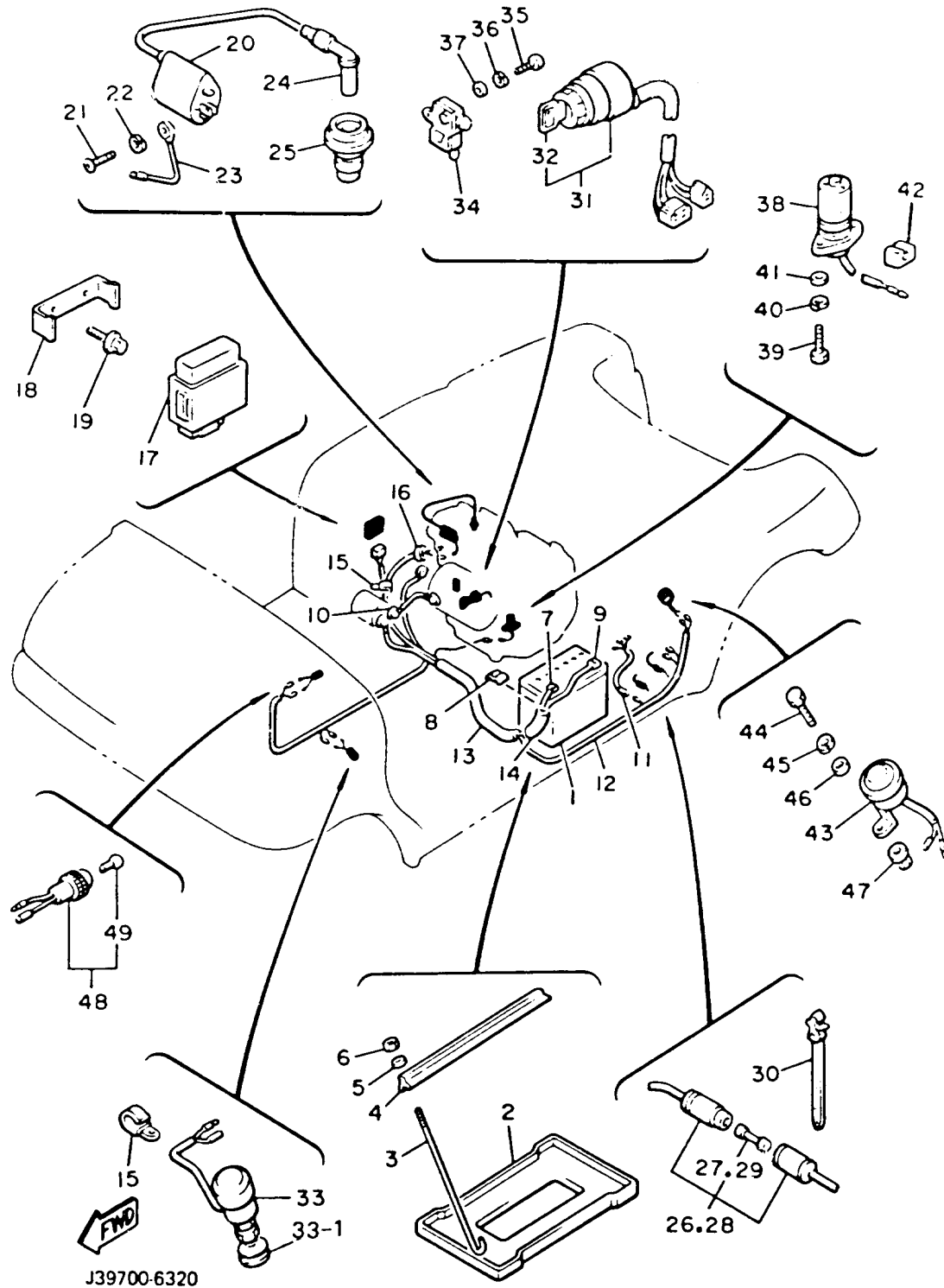

CONTINUED ON NEXT FRAME ►

ELECTRICAL 2

Ref. No.	Part Number	Description	Qty	Remarks
27	1E6-82151-00-00	. FUSE (10A)	2	
28	1E6-82150-00-00	FUSE HOLDER ASSEMBLY	1	
29	1E6-82151-00-00	. FUSE (10A)	2	
30	90464-12036-00	CLAMP	2	
31	J55-82510-00-00	MAIN SWITCH ASSEMBLY	1	
32	J17-82511-20-00	. KEY, MAIN SWITCH	2	
33	J41-82550-00-00	STOP SWITCH ASSEMBLY	1	
34	J38-82617-00-00	SWITCH	1	
35	98511-04025-00	SCREW, PAN HEAD	1	
36	92901-04100-00	WASHER, SPRING	1	
37	92901-04600-00	WASHER, PLATE	1	
38	JH2-85720-00-00	OIL LEVEL GAUGE ASSEMBLY (JF2-85720-00-00)	1	
39	97023-06020-00	BOLT (3XF)	2	
40	92995-06100-00	WASHER, SPRING	2	
41	92990-06600-00	WASHER, PLATE	2	
42	J38-82598-00-00	GROMMET	1	
43	J10-83383-02-00	BUZZER	1	
44	97313-06016-00	BOLT, HEXAGON	1	
45	92995-06100-00	WASHER, SPRING	1	
46	92990-06600-00	WASHER, PLATE	1	
47	95702-06600-00	NUT, FLANGE	1	
48	70R-83530-00-00	PILOT LIGHT ASSEMBLY	1	
49	123-83516-21-00	. BULB (12V-3.4W)	1	
	UNA-VAILA-BL-EI 0 0			
	ϕXK-0W800-00-0-	LIGHTING KIT		N/A
7-1	90108-06420-00	. BOLT, BATTERY CABLE	1	
7-2	92801-06000-00	. NUT, BATTERY CABLE	1	
9-1	90108-06420-00	. BOLT, BATTERY CABLE	1	

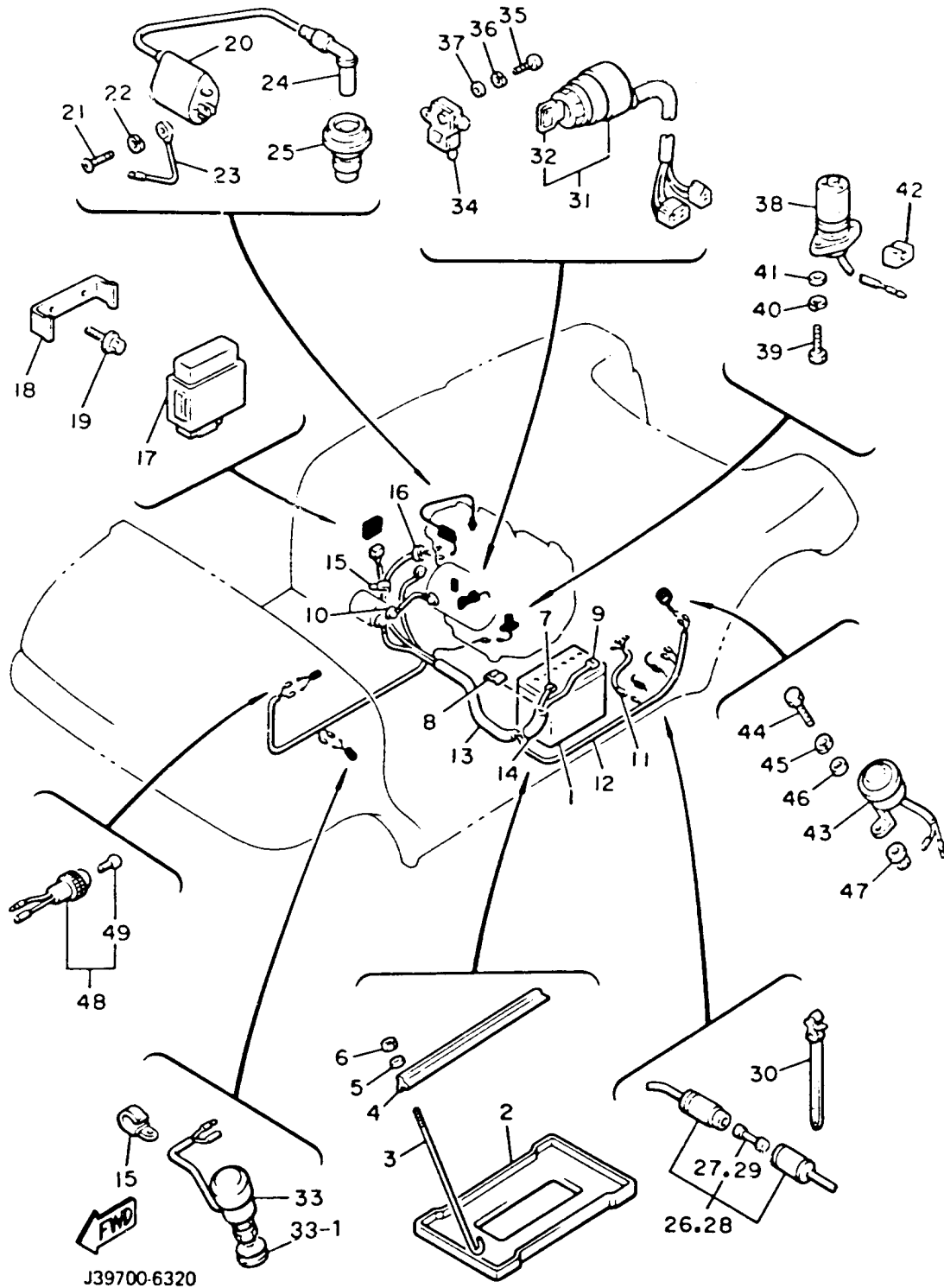

CONTINUED ON NEXT FRAME ►

ELECTRICAL 2

Ref. No.	Part Number	Description	Qty	Remarks
9-2	92801-06000-00	. NUT, BATTERY CABLE	1	
33-1	JF2-82532-00-00	. CAP, RUBBER	1	

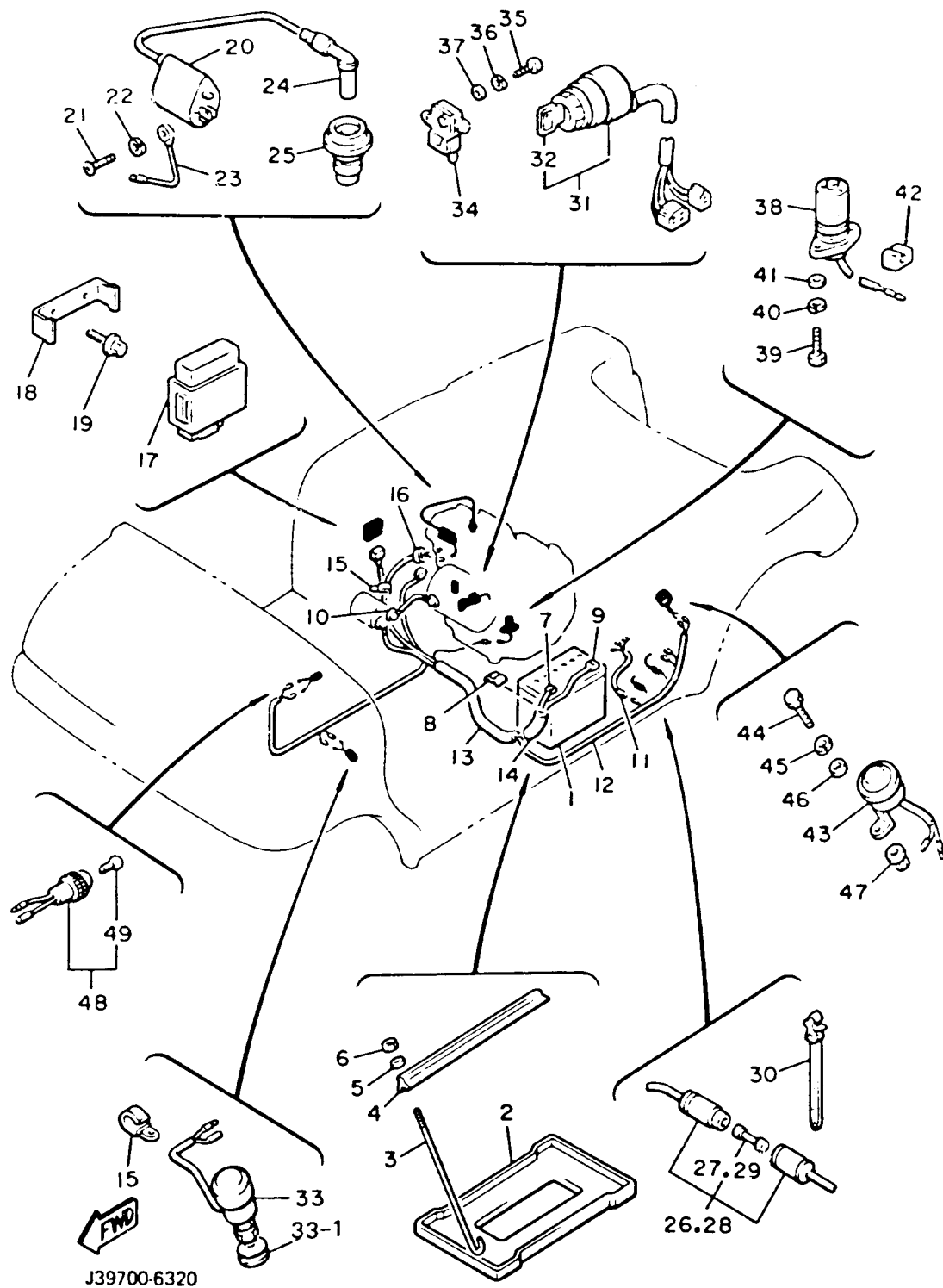

LIGHTING KIT

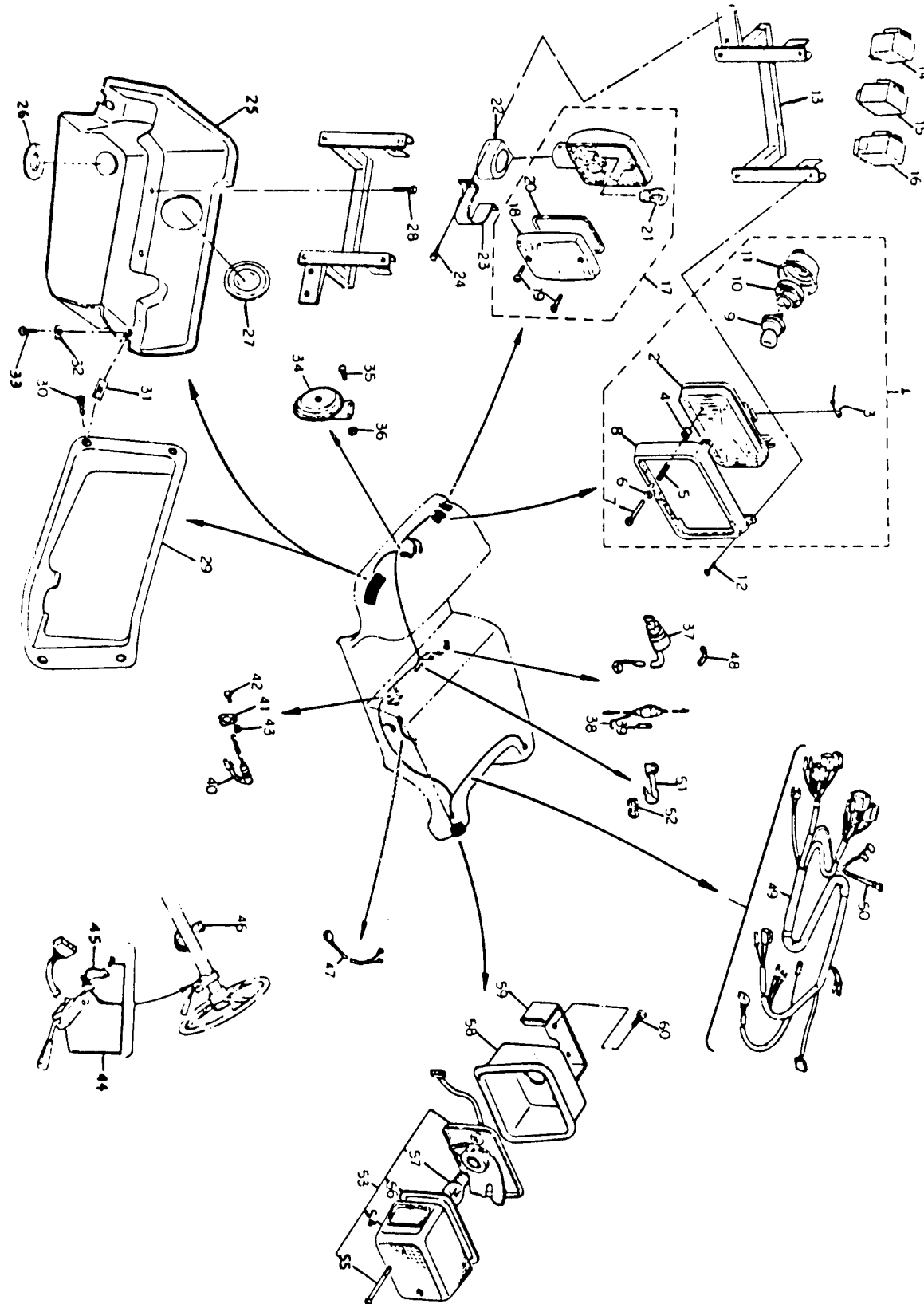

Ref. No.	Part Number	Description	Qty	Remarks
1	ϕXK-08431-00-0-	. HEAD LIGHT UNIT ASS'Y	2	N/A
2	42U-84321-60-00	. LENS ASSEMBLY	1	
3	14T-84124-00-00	. SET SPRING (5G2-84324-A0)	1	
4	198-84334-60-00	. NUT, ADJUSTING	2	
5	341-84332-60-00	. SPRING, SCREW	2	
6	233-84127-60-00	. WASHER, SPECIAL	2	
7	43F-84131-00-00	. SCREW, RIM ADJUSTER	2	
8	ϕXK-08431-50-00	. RIM, headlight	1	
9	1U4-84314-40-XX	. BULB, HEAD LIGHT (12V-45/40W)	1	
10	341-84393-40-00	. HOLDER, BULB	1	
11	46X-84396-00-00	. COVER	1	
12	ϕ97-60205-11-20	. SCREW, panhead w/w	8	
13	ϕXK-09713-10-00	. BRACKET, headlight (Left)	1	
	ϕXK-09713-20-00	. BRACKET, headlight (Right)	1	
14	33M-83350-20-00	. FLASHER RELAY ASS'Y	1	
15	J42-83350-00-00	. FLASHER RELAY ASS'Y	2	
16	J42-85590-01-00	. CONTROL UNIT ASSEMBLY	1	
17	15R-83310-70-00	. FRT FLSHR LITE ASSEMBLY (10L-83330-70)	1	
18	4G0-83312-00-00	. LENS, FLASHER	1	
19	97701-40518-00	. SCREW, TAPPING	2	
20	4G0-83313-00-00	. GASKET, FLSHR LENS	1	
21	ϕ25-68331-16-00	. BULB (12V-27W)	1	
22	ϕXK-08332-10-00	. DAMPER, flasher	2	
23	ϕXK-08336-80-00	. STAY, flasher	2	
24	ϕ97-60206-11-60	. SCREW, panhead w/w	4	
25	ϕXK-09714-90-00	. HOUSING, headlight (Left)	1	
	ϕXK-09715-00-00	. HOUSING, headlight (Right)	1	

CONTINUED ON NEXT FRAME ►

LIGHTING KIT

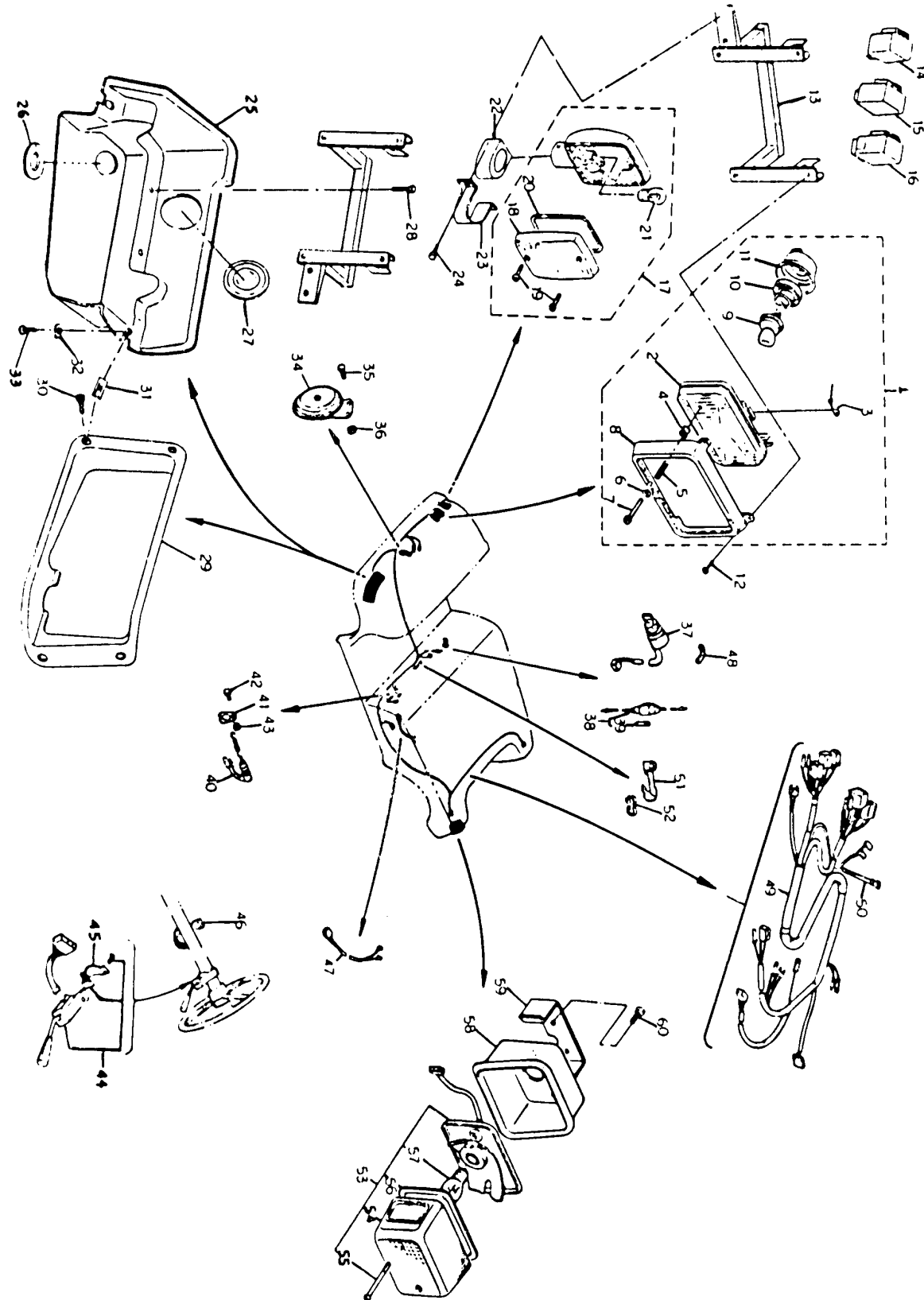

Ref. No.	Part Number	Description	Qty	Remarks
26	ϕ90-48024-43-90	. GROMMET	2	
27	ϕXK-09714-80-00	. PLUG, headlight cover	2	
28	ϕ97-50206-63-50	. BOLT, hexagon head w/w	4	
29	ϕXK-09711-50-00	. COVER, headlight (L)	1	
	ϕXK-09711-60-00	. COVER, headlight (R)	1	
30	ϕ97-70650-31-60	. SCREW, oval head tapping	8	
31	90183-06035-00	. NUT, SPRING	12	
32	92990-05200-00	. WASHER, PLAIN	4	
33	97780-50120-00	. SCREW, TAPPING	4	
34	1E2-83371-21-00	. HORN	1	
35	97313-06016-00	. BOLT, HEXAGON	2	
36	95701-06500-00	. NUT, FLANGE	2	
37	ϕXK-08252-00-00	. LAMP, switch ass'y	1	
38	2J2-82150-10-00	. FUSE HOLDER ASSEMBLY	1	
39	682-82151-00-00	. FUSE (20A)	1	
40	J13-82530-00-00	. STOP SWITCH ASS'Y	1	
41	J13-25656-00-00	. BRKT, STOP LT SWCHSTOP LIGHT SWITCH	1	
42	97313-06016-00	. BOLT, HEXAGON	1	
43	95701-06500-00	. NUT, FLANGE	1	
44	ϕXK-08397-50-00	. SWITCH HANDLE	1	
45	ϕXK-08395-50-00	. BRACKET 1	1	
46	25G-83936-01-00	. BAND, SWITCH CORD	2	
47	ϕXK-08212-70-00	. WIRE LEAD 2	1	
48	J38-77742-00-00	. INDICATOR 2	1	
49	ϕXK-08258-00-00	. WIRE HARNESS ASS'Y	1	
50	12R-82591-00-00	. BAND	8	
51	ϕXK-08259-40-00	. CLAMP	1	
52	ϕ1A-02588-10-10	. PROTECTOR, brake	1	

CONTINUED ON NEXT FRAME ►

LIGHTING KIT

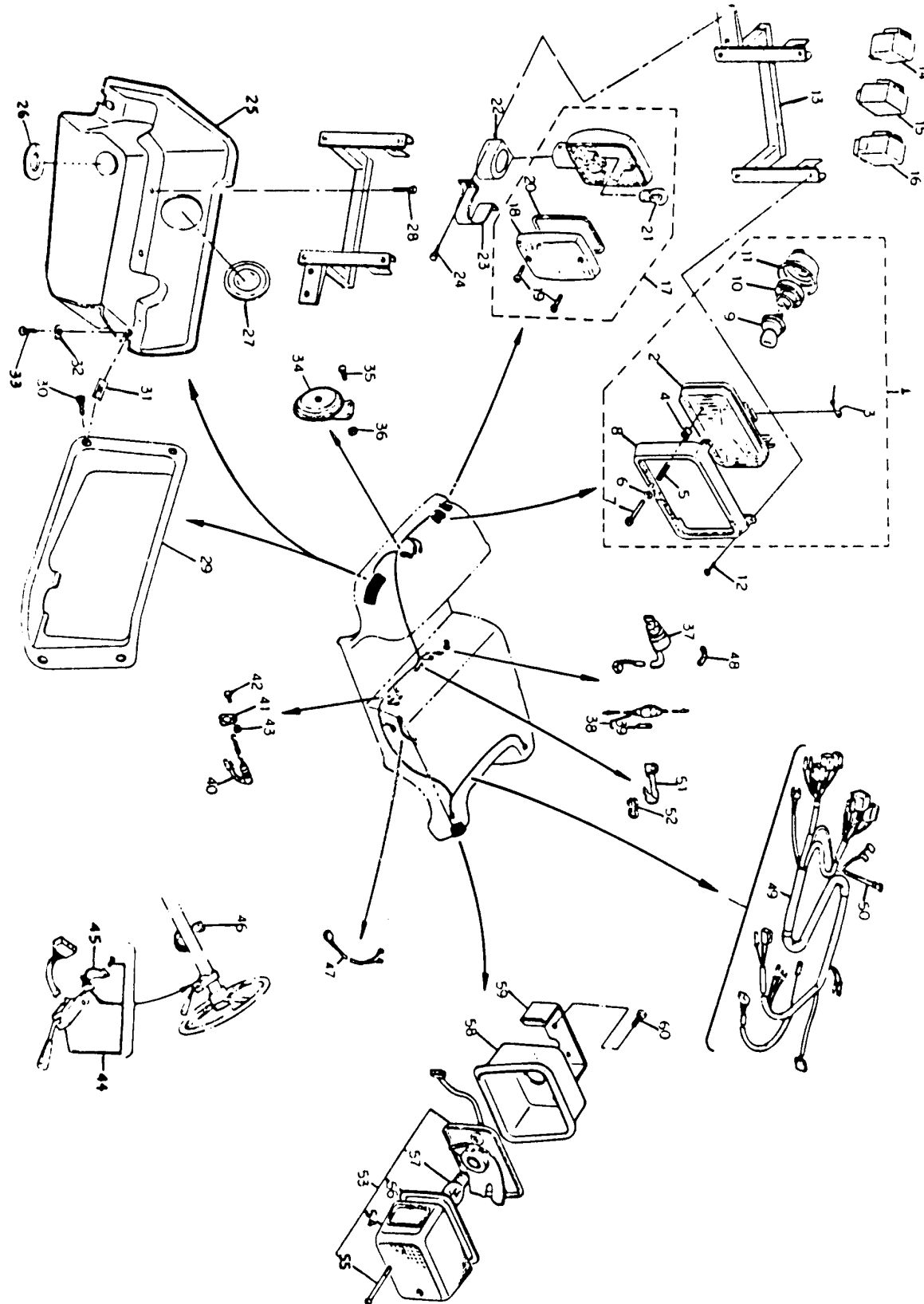

Ref. No.	Part Number	Description	Qty	Remarks
53	13W-84710-00-00	. TAILLIGHT UNIT ASS'Y	2	
54	1M8-84521-40-00	. LENS, TAILLIGHT	1	
55	1M1-84524-60-00	. SCREW, LENS FITTING	1	
56	1M1-84523-60-00	. GASKET, LENS	1	
57	256-84714-61-00	. BULB (12V-27/8W)	1	
58	ϕXK-09712-10-00	HOUSING, taillight	2	
59	ϕXK-09711-20-00	. BRACKET, taillight	2	
60	ϕ97-50206-41-60	. BOLT, hexagon head w/washer	4	

BUMPER

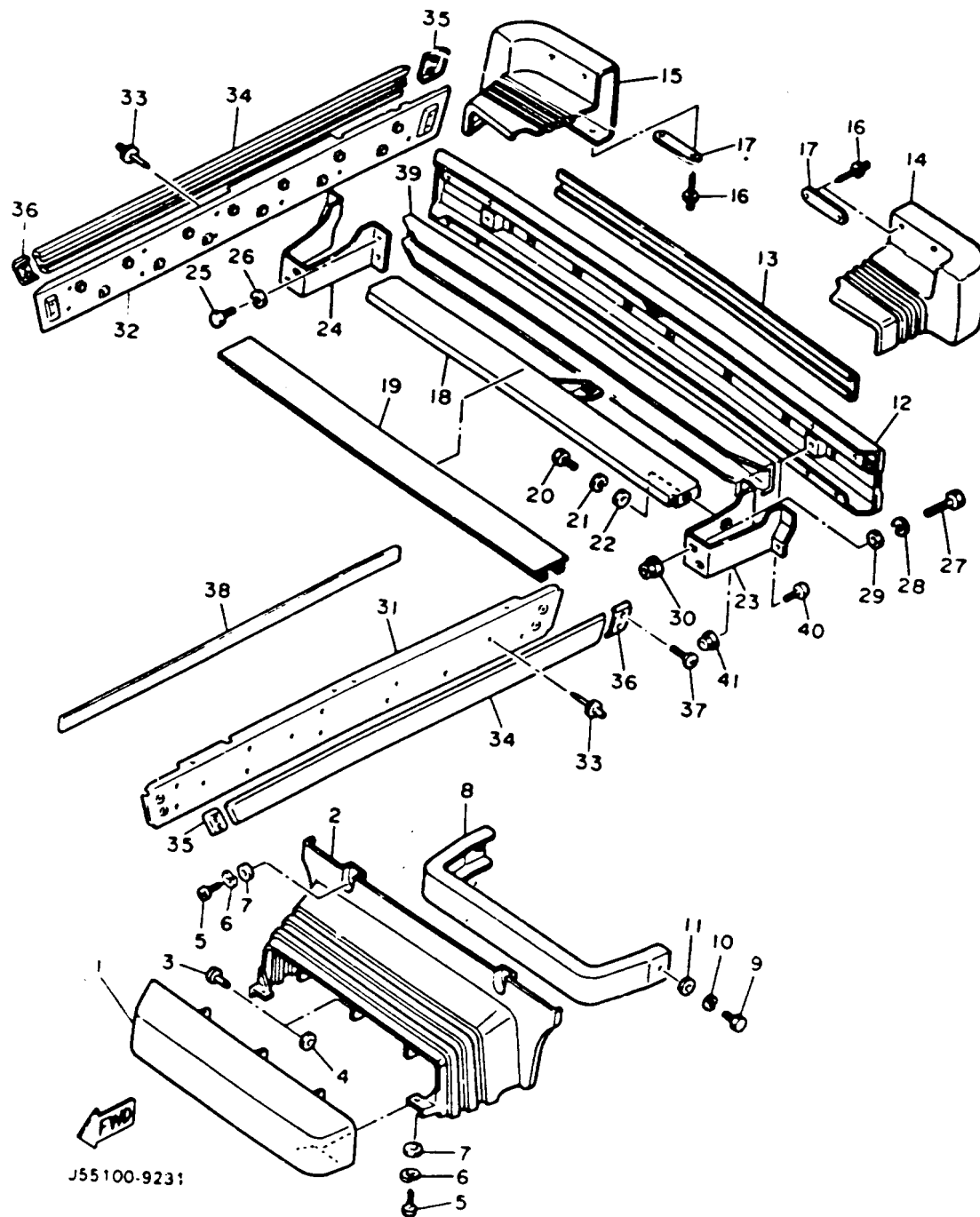

Ref. No.	Part Number	Description	Qty	Remarks
2	J55-K8163-00-00	COVER, BUMPER	1	
3	90269-06028-00	RIVET	3	
4	90201-076J4-00	WASHER, PLATE	3	
5	98506-05020-00	SCREW, PAN HEAD	4	
6	92906-05100-00	WASHER, SPRING	4	
7	90201-05033-00	WASHER, PLATE	4	
8	J55-K7511-00-00	BUMPER, FRONT 1	1	
9	97022-08016-00	BOLT	2	
10	92990-08100-00	WASHER	2	
11	92990-08600-00	WASHER, PLATE	2	
12	JG5-K8107-00-00	BUMPER SUB-ASSEMBLY, REAR	1	
13	J55-K8172-00-00	PAD, REAR BUMPER (J38-78172-00)	1	
14	J55-K8167-00-00	BUMPER, RUBBER 1	1	
15	J55-K8168-00-00	BUMPER, RUBBER 2	1	
16	90267-40077-00	RIVET, BLIND	8	
17	J17-77525-00-00	WASHER 1	4	
18	J38-78179-01-00	PLATE, EXTENSION	1	
19	J55-K8178-00-00	COVER, EXTENSION PLATE (J38-78178-00)	1	
20	97016-08016-00	BOLT	3	
21	92906-08100-00	WASHER, SPRING	3	
22	92906-08600-00	WASHER	3	
23	J55-K8174-00-00	STAY, REAR BUMPER (J38-78174-01)	1	
24	J55-K8175-00-00	STAY, REAR BUMPER 2 (J38-78175-01)	1	
25	97313-08016-00	BOLT, HEXAGON	6	
26	92906-08100-00	WASHER, SPRING	6	

CONTINUED ON NEXT FRAME ►

BUMPER

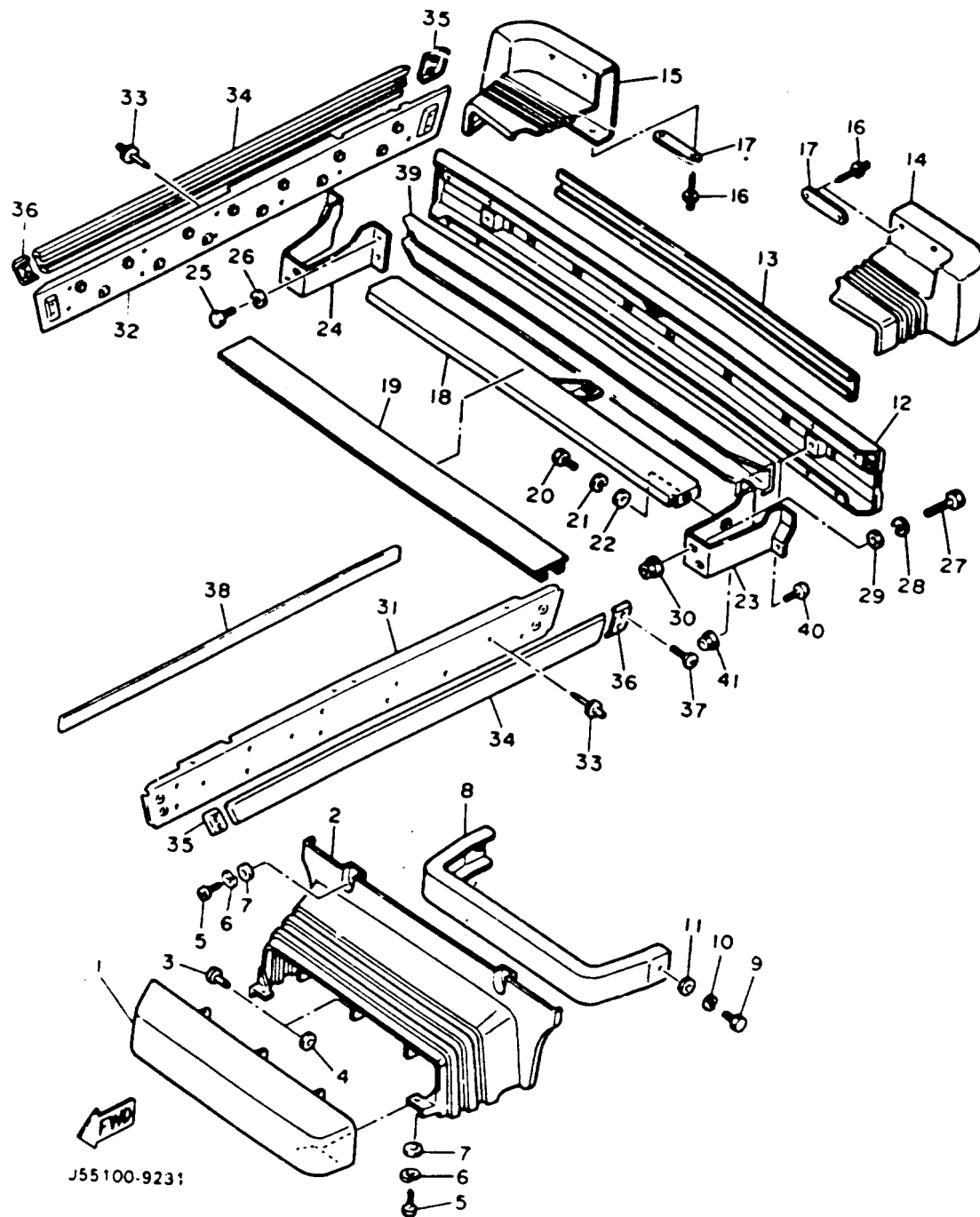

Ref. No.	Part Number	Description	Qty	Remarks
27	97026-08050-00	BOLT	4	
28	92906-08100-00	WASHER, SPRING	4	
29	92906-08600-00	WASHER	4	
30	95706-08500-00	NUT, flange	4	
31	J55-WK811-00-00	PLATE, SIDE SILL KIT (L.H) (J55-K8183-00)	1	
32	J55-WK812-00-00	PLATE, SIDE SILL KIT (R.H) (J55-K8184-00)	1	
33	90267-48139-00	RIVET, BLIND	18	
34	J55-K818A-00-00	PROTECTOR, SIDE PLT	2	
35	J38-7818E-00-00	CAP, PROTECT.END 1	2	
36	J38-7818F-00-00	CAP, PROTECT.END 2	2	
37	98606-06014-00	SCREW, OVAL HEAD (92606-06014)	8	
38	J55-78181-00-00	PLATE 1	4	AP
39	J55-77529-00-00	SPACER, BUMPER	1	AP
40	92016-08016-00	BOLT, BUTTON HEAD	2	AP
41	95706-08500-00	NUT, flange	2	AP

G2-AM5, A, AB BATTERY OVERCHARGING

Effective 5/6/87, this Technical Bulletin replaces G86-009A. Please remove and destroy G86-009A. Denotes a change in the original Technical Bulletin.

On some of the units in the affected ranges, the voltage regulator was not set properly at the factory. An incorrectly adjusted regulator may cause overcharging of the battery, resulting in a rapid loss of battery fluid. To correct this problem, units found to have high voltage output must be correctly adjusted. Units in the affected range should be inspected any time rapid fluid loss is evident, or during the next routine maintenance.

AFFECTED UNITS

- G2AM5 J38-000101 ~ 005280
- G2A J38-007101 ~ 018590
J38-066101 ~ 070910
- G2AB J38-020101 ~ 023534

NOT AFFECTED UNITS*

- G2AB J38-023535 ~ 066100

*DO NOT INSPECT UNITS IN THIS SERIES

WARNING

A battery contains harmful sulphuric acid, and, while charging or overcharged, emits potentially explosive hydrogen gas. To reduce the possibility of an explosion, never service or charge a battery in a closed area, or when an open flame or sparks are present.

INSPECTION

1. Lock the car in neutral. Insert the lock pin or alternately, remove the drive belt.
2. Connect a pocket tester (0 ~ 20-volt DC range) to the battery terminals.
3. Connect a variable tachometer (a suitable one is available from Kent-Moore; the part number is YU-8036). Start and rev the engine to maximum charging speed (2500 rpm or higher); maintain that speed for 15 seconds or more, to ensure the charging system has stabilized, and read the output voltage on the meter.

If the voltage reading is within the range of 15.0 ± 0.5 volts, no adjustment is necessary. If the voltage reading is not within specification, proceed to ADJUSTMENT.

ADJUSTMENT

1. Refer to the service manual and remove the rear body panel.
2. Remove the voltage regulator cover.
3. Loosen the lock nut securing the voltage adjustment screw.
4. Turn the adjustment screw so that maximum output indicated at the battery terminals is no higher than 15.0 ± 0.5 volts.

NOTE: To LOWER the voltage, turn the screw counterclockwise. To RAISE the voltage, turn the screw clockwise.

5. Tighten the lock nut, replace the cover, and reconnect for proper output.

6. Disconnect the meter, remove the neutral lock pin (or reinstall the drive belt), and reassemble the unit.

WARRANTY PROCEDURE

There is no warranty allowance for inspection. The warranty labor allowance for voltage regulator adjustment is 0.3 hours. The problem code is 90HJ. To receive credit, follow the standard service-per-bulletin procedures.

90HJ
If this problem code does not describe the trouble.

(For additional information see reverse side)

WARRANTY PROCEDURE FOR OVERCHARGED BATTERY

In some cases, the high regulator setting has caused battery damage even with proper routine battery maintenance. Battery manufacturers expect, on average, a usable life span of three years on a battery for a gasoline-powered golf car. Yamaha will pay for the unused portion of that three year period on a battery damaged as a result of the problem described in this bulletin. The time frame is determined by the date of registration. The first year, Yamaha pays 100% of your cost for the battery. The second year rate is 67%; third year of use is 33%.

These conditions must be met to qualify for any battery coverage:

1. The car must have been sold and registered with YMAUS prior to 10/15/86 (the date Technical Bulletin G86-009A was released).

2. A request for the service-per-bulletin referred to in this bulletin (90HJ) must be filed for the affected car.

3. A copy of the battery purchase receipt or invoice showing the battery cost must be on file with the Warranty Department. Once a receipt has been submitted, it is not necessary to send receipt copies if additional claims are made, unless the battery cost is different. Please send these copies to your Regional Service Representative. The addresses are listed below:

Eastern Regional Service
ATN Golf Car Service
Two Elkader Court
Indigport, NJ 08014

Western Regional Service
ATN Golf Car Service
6655 Korteia Ave
Cypress, CA 90630

4. A separate request must be filed for each car. No blanket coverage or credits will be issued.

5. Use standard warranty procedures and problem code 83. The new DOES PLUS multiple request procedure may be use 1.

6. The batteries are not supplied by Yamaha. To reimburse your dealership for the battery purchase, the cost must be converted to nearest hours and tenths and inserted in the Extra Labor section (10) of the Warranty Request. Do not enter this cost as Sublet Labor. Use this formula to convert to hours:

Multiply: battery cost x percent of coverage (as stated earlier), divided by your hourly labor rate. Round off the amount to the nearest 1/10 hr. Example:

\$25.00 dealer cost for battery for a G2-A sold and registered on 7/1/85; dealer labor rate \$25/hr.

$\$25.00 \times 67\%$ divided by $\$25/\text{hr} = .67 \text{ hr}$; round off to the nearest tenth of an hour = 0.7

WARRANTY REQUEST FORM

Model: G2-A
Year: 1985
VIN: J38-000101-005280
Date of purchase: 7/1/85
Dealer name: []
Dealer address: []
Dealer phone: []
Customer name: []
Customer address: []
Customer phone: []
Problem description: []
Problem code: 90HJ
Submitted by: []
Submitted on: []

There is no labor allowance because the minimal time required to exchange the battery is adequately covered in the service-per-bulletin allowance and our prorated battery coverage.

No claims will be accepted after October 15, 1987. This time period allows one year to adjust the regulator and monitor the situation. Please remind your customers of the necessity for routine battery maintenance as stated in the Service Manual.

G2-A

FUEL PUMP CLOGGING/PUMP REBUILDING

Effective 10/1/87, this Technical Bulletin replaces G86-014, please remove and destroy G86-014. Denotes a change in the original Technical Bulletin.

Some G2-A engines may experience erratic performance or stall completely due to fuel pump clogging. Water and other contaminants can leave residue and corrode the inside of the fuel pump pulse chamber, stop-

ping fuel flow to the engine. If corrosion is found, the pulse chamber cover should be replaced with a new fluorine resin-coated cover (green inside coating) available from YPOL.

AFFECTED UNITS

- 1985 G2-AM5 J38-000101 ~ 005280
- 1986 G2-A J38-007101 ~ 018590;
066101 ~ 070910
- 1987 G2-AB J38-020101 ~ 024968
- 1987 G2-A J38-039010 ~ 039489
- 1988 G2-A J38-071101 ~ 072004

SERVICE PROCEDURE

WARNING

Gasoline and its vapor are highly flammable and explosive. Keep fuel away from sparks, lit cigarettes, or flame. Work in a well-ventilated area.

1. Lift the car mid-body for engine access. The fuel pump is mounted on the side of the fuel tank.
2. Remove the crankcase pulse hose from the pump plug or clamp the hose from the fuel tank and carburetor to prevent fuel leakage.
3. Remove the six Phillips screws holding the pump and pump cover together.

NOTE: If complete rebuilding is necessary, refer to page 2 of this bulletin under "ADDITIONAL PARTS INFORMATION."

4. Remove the pulse chamber cover and install the new one.
5. Reassemble by reversing this procedure.

WARNING

Make sure the thin rubber seals, diaphragms, and gaskets are installed in the proper sequence. Improper assembly may cause diaphragm damage and fuel leakage. Proper assembly order is shown in the illustration under "ADDITIONAL PARTS INFORMATION" on page 3 of this bulletin.



PARTS INFORMATION

PART NUMBER	DESCRIPTION	REMARKS	DEALER COST
J38-24452-19-00	Pulse Chamber Cover	Green coating inside	

NOTE: The current replacement pulse chamber cover will not contain this seal. See chamber covers will not contain this seal. See Additional Parts section on page 3 of this bulletin for Diaphragm Kit information.

WARRANTY PROCEDURE

35

The warranty labor allowance for this procedure is 0.1 hrs. The problem code is 35. List the cover part number as the primary billed part. Write "per bulletin G86-014A" in sections 11, 13, 14, and 15."

NOTE: Do not put parts or labor for fuel pump rebuilding on the Warranty Request for cover replacement.

WARRANTY REQUEST FORM

Model: G2-A
Year: 1987
VIN: J38-020101-024968
Date of purchase: []
Dealer name: []
Dealer address: []
Dealer phone: []
Customer name: []
Customer address: []
Customer phone: []
Problem description: []
Problem code: 35
Submitted by: []
Submitted on: []

ADDITIONAL PARTS INFORMATION

A fuel pump diaphragm kit is now available from YPDI for the G2-A. It is not shown on the current microchic.

SERVICE PROCEDURE

Follow steps 1, 2 and 3 for the fuel pump cover installation. Refer to the exploded view and reassemble the fuel pump using the new diaphragm, gaskets, and seals included in the kit.

PARTS INFORMATION

PART NUMBER	DESCRIPTION	REMARKS	DEALER COST
38WH1391-01-00	Diaphragm Kit	Fuel pump rebuilding kit for G2-A	

WARRANTY PROCEDURE

Normal warranty procedures apply. That is, warranty will only pay for fuel pump rebuilding to repair a defect. The Diaphragm Kit is not needed to repair a clogged fuel pump. If you have any questions, please contact your Regional Service Representative.

G2-A WIRE HARNESS PROTECTION

INTRODUCTION

PROBLEM: Possible damage to wiring harness or starter solenoid relay.

REMEDY: Install a cable tie around the harness and frame to secure the harness and keep it from becoming fouled.

CAUSE: Vegetation, brush, or other debris may catch the wire harness near where the starter solenoid relay is mounted.

DEALER ACTION SUMMARY

1. Obtain locally a supply of at least 8-inch-long cable ties.
2. Install a cable tie on all affected units.
3. File a service-per-bulletin (90-HW) Warranty Request.

AFFECTED UNITS

G2-AMS 1985 J38-000101 ~ 005280
 G2-A 1986 J38-007101 ~ 018590
 J38-066101 ~ 070910
 G2-AB 1987 J38-020101 ~ 039000

SERVICE PROCEDURE

1. Open the seat cowl to gain access to the harness. Inspect the harness for any frayed or broken insulation or wires. If necessary, make appropriate repairs.
2. Position the wire harness, as shown, near the top of the frame tube, so it cannot be fouled.

NOTE: It may be necessary to loosen the nut that holds the positive (+) battery cable to the solenoid relay; rotate the L-shaped cable terminal toward the rear to position the battery cable so it cannot be fouled, and retighten the nut.

(For additional information see reverse side)

3. Securely wrap the cable tie around the frame tube, heavy starter cable, and the right-hand portion of the harness that includes the wires to the starter relay. Trim the cable tie, if necessary.

CAUTION:

Make sure the low-voltage White/Red and Black wires that go to the terminals on the starter solenoid relay are not too taut once the cable tie is tightened. If necessary, increase slack by working the harness through the cable tie toward the relay. Also make sure the White/Red, Green, and Black wires which are joined with snap connectors are not secured under the cable tie.

4. Close the seat cowl.

PARTS INFORMATION

Because there are numerous local sources (auto parts houses, electronics stores, hardware stores, etc.) in each dealership area, the required cable tie (at least 8" in length) can be obtained readily and inexpensively. Each dealer will be automatically reimbursed for one cable tie with each warranty request submitted (see WARRANTY INFORMATION for details). No other parts are necessary.

WARRANTY INFORMATION

The labor allowance for this operation is 0.1 hours. The problem code is 90HW.

To receive credit, submit a standard service-per-bulletin request.

90HW
 (Use this problem code for description on repair)

NOTE: A payment of 30 cents (plus 10% handling) will be automatically added to the parts category of each warranty request to cover the cost of the locally-obtained cable tie.

GOLF CAR DATE: 5-20-87 AX: G87-002

G2-A (J38) SERVICE MANUAL CORRECTION

INTRODUCTION

The CHAMPION spark plug listed on pages 7-29 and 8-7 in the G2-A Service Manual is incorrect. The correct spark plug has a 3/4" thread reach and not 1/2" as listed in the manual. Performance is adversely affected by using the incorrect spark plug.

AFFECTED UNITS

All G2-A (Starting I.D. J38-000101)

DEALER ACTION SUMMARY

All service manuals should be modified to reflect the changes dealt with in this bulletin. Also notify all service personnel of these corrections.

HOW TO READ NGK SPARK PLUG I.D. NUMBERS

If replacement of the spark plug is necessary, use the correct type/number/heat range as listed. Spark plug installation torque is 14 ft lb (2.0mkg).

RECOMMENDED SPARK PLUG FOR:

	NGK	CHAMPION
G1-A, G3-A	BPSHS	L89CM
G2-A	BSES	NSC N8

CORRECT FOR G2-A
 NGK BSES or CHAMPION N8, NSC

INCORRECT FOR G2-A
 CHAMPION L89CM

WARRANTY

This bulletin is for informational purposes only. No special warranty procedures apply.

G2-A SHIFT CABLE PERIODIC LUBRICATION

INTRODUCTION

PROBLEM: Some units in the affected ranges have experienced difficult shifting after being in use for periods of a year or more.

REMEDY: To make certain this situation does not inconvenience any customer, an annual lubrication of the shift cable with Yamaha Lube-Zall will minimize the possibility of sticking.

CAUSE: Moisture can enter the ends of the shift cables during normal use. This can form rust and corrosion and cause the inner cable to bind.

DEALER ACTION SUMMARY

Add yearly shift cable lubrication to the service schedule of all G2-A's.

AFFECTED UNITS

G2-AMS	1985	J38-000101 ~ 036308
G2-A	1986	J38-007101 ~ 018590
G2-AB	1987	J38-020101 ~ 036308 J38-066101 ~ 070910

NOTE: All 1987 G2-AB units after ID number J38-036308 (except J38-066101 ~ C70910) are fitted with an improved shift cable that has a stainless steel inner wire. However, the yearly lubrication procedure should still be followed to preserve smooth cable operation.

SERVICE PROCEDURE

Lubricate the shift cables on all units with Lube-Zall at least once a year, using a Yamaha Power Cable Injector tool. Follow the instructions on the tool package.

NOTE: If a cable has become loose, follow the service manual and replace it. Lubricate the new cable immediately following installation, and at least once every 12 months thereafter.

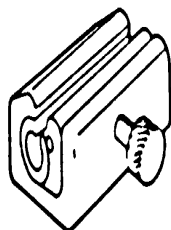

LUBE INJECTOR TOOL

PARTS INFORMATION

PART NUMBER	DESCRIPTION	REMARKS	DEALER COST
ACC-11001-41-01	Lube-Zall	12 cans per Case	
ACC-11110-43-11	Power Cable Injector	10 per package	

The improved shift cables will be carried in YPDI stock as soon as current supplies are depleted.

The part number of the improved cable remains the same. However, a white sleeve has been placed around the outer cable to identify the improved version.

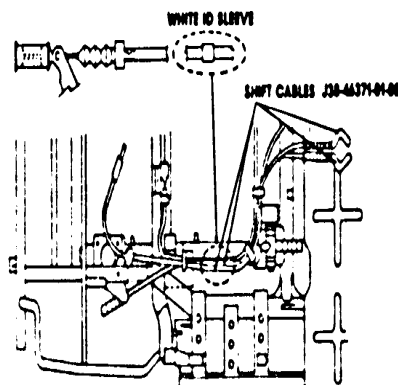

WARRANTY INFORMATION

If a unit is in warranty and a loose shift cable is replaced, follow normal warranty procedures for cable reimbursement. No warranty applies for annual lubrication, as this is a routine maintenance operation.

G2-A STARTER BRUSH WEAR

INTRODUCTION

PROBLEM: The starter does not operate properly.

CAUSE: The starter generator brushes have worn.

REMEDY: Install new starter generator brushes.

NOTE: There are two types of brushes that will fit the J10 and the J38.

The J10-type is harder and less conductive than the J38. These brushes will last longer but their use may result in cold weather starting problems.

The J38-type is softer and more conductive. These brushes are required for colder weather starting.

NOTE: Always use only the J10 brushes with the G1-A.

DEALER ACTION SUMMARY

When you find a G2-A whose starter generator brushes have worn out, use the information in this bulletin. Make sure you obtain and install

the brush set that applies to the temperature range in which the car will be operated.

AFFECTED UNITS

All G2-A

PARTS INFORMATION

Brush Set Part Number	Remarks	Dealer Cost
J10-81111-10-00	Can use in temperatures above 41°F (5°C) on G2-A for increased brush life.	
J38-81111-10-00	Good for all temperatures but wear more rapidly.	

NOTE: The J10 springs (J10-81113-10-00) can be used with the J10 brushes. However, only the J38 springs (J38-81113-10-00) should be used with the J38 brushes.

WARRANTY INFORMATION

This bulletin is issued for informational purposes only. No special warranty applies.

ALL GAS-POWERED MODELS PRIMARY CLUTCH WEIGHT LINK WEAR

INTRODUCTION

PROBLEM: Some units in the affected ranges may experience premature wear of the primary clutch weight link assemblies. This usually occurs on units which accumulate high mileage, such as are used as industrial vehicles or fleet cars in high-usage areas.

CAUSE: Grease on the clutch weight links collects dirt which wears the clutch weight link bushings and pins.

REMEDY: Inspect, lubricate and clean the area during routine maintenance. Install improved weight link kits and replace the pins if excess wear is found.

DEALER ACTION SUMMARY

1. Add inspection, lubrication, and cleaning of the primary clutch to the normal service procedures.

2. If any unit experiences worn primary clutch weight links, install three improved weight link kits and replace the link pins.

NOTE: Some of the common signs of worn weight links are squeaking, vibration, or rattling from the primary clutch.

3. File a service-per-bulletin warranty request for any repair.

AFFECTED UNITS

G1AM	J31-140101 ~ 154371	G2AB	J38-020101 ~ 035489
G2AMS	J38-000101 ~ 006999		J38-071101 ~ 072305
G2A	J38-007101 ~ 019999	G3A	J42-000101 ~ 302818
	J38-066101 ~ 070999		

SERVICE PROCEDURE

PERIODIC INSPECTION

1. Open the rear cowling, and remove the drive belt.
2. Remove the primary clutch cap screws and the clutch cap.
3. Inspect the sliding sheave for smooth operation. Check for play between the pivot pins and weight link assemblies.



If the pins and weight link assemblies are not worn, and the sliding sheave operates smoothly, remove any dirt and old grease, and apply two to three shots of molybdenum disulfide grease to the grease fitting to lubricate the shaft. Remove any excess grease from the clutch and reassemble the unit. Greasing should be done only with clutch cap removed.

(For additional information see reverse side)

SERVICE PROCEDURE (Cont'd)

CAUTION

Make sure the clutch assembly is free of grease, oil, and dirt. Dirt will adhere to any grease or oil left on the clutch. This is the primary cause of premature wear of both the weight link bushings and pins, and the slider bushings.

- If any of the pins or weight link assemblies are worn, install three weight link kits and six pins.

WEIGHT LINK INSTALLATION

1. Disassemble the primary clutch according to the instructions in the service manual.
2. Follow the service manual and install the new links and pins. Do not lubricate these parts.

NOTE: The link kit contains different parts than were removed during disassembly. You must use the illustration in this bulletin to make sure the new parts are installed correctly.

3. Apply molybdenum disulfide grease to the grease lining as necessary, remove any excess, and reassemble the unit.

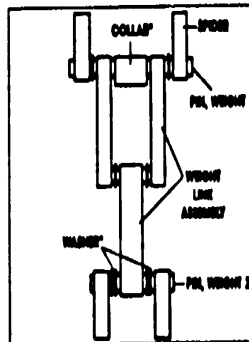
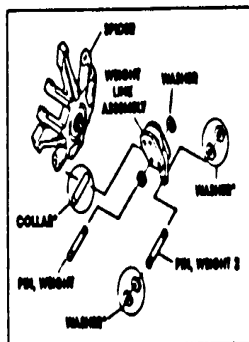

*Newly added parts

PARTS INFORMATION

Part Number	Description	Qty	Remarks	Dealer Cost
99999-01831-00	Weight link kit	3	For G1-A and G3-A models	
99999-01830-00	Weight link kit	3	For G2-A models	
138-46236-00-00	Pin, Weight 1	3	For all models	
138-46237-00-00	Pin, Weight 2	3	For all models	

NOTE: Make sure the correct weight link kit are ordered (these kits contain the necessary collar and washers). Order three of the correct weight link kits and three of each of the two different pins for each unit.

9013 CAR DATE 12/31/87 RA G87-008

WARRANTY INFORMATION

There is no warranty allowance for routine maintenance which includes inspection, cleaning, and lubrication.

Labor allowance for installing the weight link kit is 0.7 hours. The problem code is 9013. To receive credit, follow normal service-per-bulletin procedures.

9013 0.7
is the problem code list describe the issue hours labor

ROUTE TO: SERVICE PARTS WARRANTY SALES PAGE 1 OF 3

G2 SEAT COVER INSPECTION AND REPAIR

Effective 12/89 this Technical Bulletin replaces G81 002 please remove and destroy G88 002. * Denotes a change in the original Technical Bulletin

INTRODUCTION

PROBLEM: Hole in the seat cover on the side by the driver's side armrest. **REMEDY:** Remove the staples and or replace the seat cover if it is damaged by incorrect staple placement.

CAUSE: Some of the staples used to secure the seat cover to the seat base near the armrest mount may wear through the seat foam and puncture the cover.

DEALER ACTION SUMMARY

For units with no seat cover damage, both new unsold units and units already in service, remove the staples near the armrest side of the seat as shown in this bulletin. For sold and registered units with seat cover damage caused by incorrect stapling, replace seat cover. Use 1/4" stainless steel staples when installing new cover. Follow standard 90 code procedures to file a warranty claim.

AFFECTED UNITS

G2AM5 J38-000101 ~ 009999	G2AC JA2-000001 ~ 009999
G2A J38-007101 ~ 019999	G2EM5 J41-000101 ~ 009999
G2A J38-066101 ~ 079999	G2E J41-046101 ~ 029999
G2AB J38-020101 ~ 039489	G2B J41-030101 ~ 033601
G2AB J38-071101 ~ 099999	G2EB J41-053101 ~ 059999
	G2EC JE2-000001 ~ 009999

SERVICE PROCEDURE

WARNING
 Wear proper eye protection when performing the procedures described in this bulletin.

Staple Removal Only (if no damage is present)

NOTE: Additional pre-delivery service: pull driver's side staple before assembling new units within the affected range.

1. Raise the seat cowl.
2. Open the mid-body and remove the 2 bolts securing left side of the seat to the base. Flex the seat base far enough to remove the staples near the arm rest mount on the driver's side.
3. Remove only the staple in the affected arm-rest mounting area on the seat base.
4. Reinstall the seat.

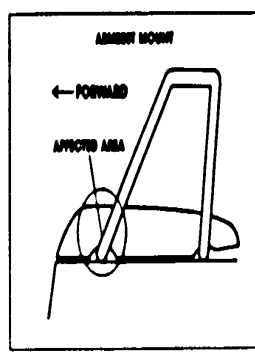

SERVICE PROCEDURE (Cont'd)

Damaged Seat Cover Replacement

1. Raise the seat cowl.
2. Remove the seat.
3. Cut the seat cover between the staples and the seat base edge.

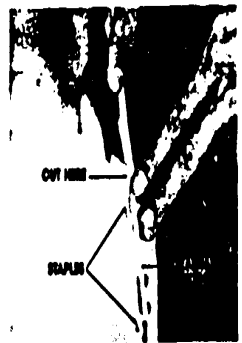

4. Use pliers to pull up the vinyl. When the vinyl is pulled up sharply, most of the staples will be pulled out. Remove any remaining staples in corners and arm rest mounting area. Discard the old seat cover.



5. Position and center the new seat cover. Staple the centers of the front, rear, left, and right sides to the seat base with a pneumatic or electric staple gun.

6. Fold and staple the corners. Install all other staples (front, back, and sides).

7. Staple the original affected area of the new angle shown in the illustration.

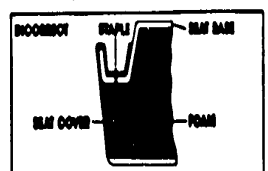

WARNING:
 Do not duplicate the original problem.

8. Trim off the excess material.

9. Reinstall the seat.

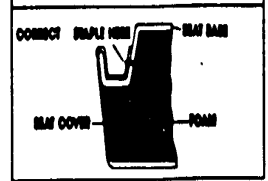

SERVICE PROCEDURE (Cont'd.)

PARTS INFORMATION			
Part Number	Description	Remarks	Dealer Cost
J38-78404-00-00	Seat cover 1/4" Stainless steel staples	Obtain from hardware store	\$36.25

WARRANTY INFORMATION	
<p>Staple Removal Only: For new unacid units and registered units with no holes (damage) labor allowance is 0.1 hour.</p>	<p>90JE1 0.1 hours</p>
<p>Seat Cover Replacement (includes staple removal): Labor allowance for seat cover replacement is 0.5 hours. Unit must be registered. Yamaha will not reimburse for claims on unregistered units in service or on units registered after 3-31-88.</p>	<p>90JE2 0.5 hours</p>

G2AB

EXCESSIVE KNOCKING AND VIBRATION

INTRODUCTION

PROBLEM: Some units may exhibit excessive knocking noise and/or vibration. This condition is easily detected during set-up and pre-delivery service.

CAUSE: An improperly machined secondary sheave causes the drive belt to ride high, then

REMEDY: Replace the secondary fixed sheave low in the secondary sheave assembly. This loads the primary clutch and crankshaft, causing a knocking or rattling noise and vibration.

REMEDY: Replace the secondary fixed sheave.

- DEALER ACTION SUMMARY**
1. Test-run and drive the car during pre-delivery service.
 2. If noise and vibration are excessive, replace the secondary fixed sheave.
 3. If the condition still exists, refer to Technical Bulletin G2B-005.

AFFECTED UNITS	
G2A	J38-072308-082516

SERVICE PROCEDURE

Refer to the Service Manual for sheave replacement procedure.

PARTS INFORMATION			
PART NUMBER	DESCRIPTION	REMARKS	DEALER COST
J38-44260-00-00	Secondary fixed sheave	G2A	
9401-29025-00	Coffer pin		

WARRANTY INFORMATION	
<p>Follow normal service per-bulletin procedure. Labor allowance for inspection and repair is 0.3 hours. The Problem Code is 90JG.</p>	<p>0.3 hours</p> <p>90JG</p>

G2-A/G2-E

SOLENOID REPAIR KIT

INTRODUCTION

PROBLEM: Solenoid plunger moves, but solenoid does not operate.

CAUSE: Internal moving parts or contacts worn or damaged.

REMEDY: Install solenoid repair kit.

NOTE: If the solenoid coil is bad, the complete solenoid must be replaced. (The solenoid coil is bad if the solenoid plunger does not move when power is applied directly to the solenoid coil wires, or if there is no continuity between the two solenoid coil wires [measured with an ohmmeter with the battery cables and wire harness disconnected.]

If the coil is good, the ohmmeter should read $62\Omega \pm 10\%$ (J-41) or $7\Omega \pm 10\%$ (J-38). Any higher readings indicate a shorted or grounded coil.

- DEALER ACTION SUMMARY**
- If a solenoid's plunger moves, but the solenoid does not operate properly, a repair kit may be installed, using the service procedures in this bulletin.

AFFECTED UNITS	
All G2-A J38	
All G2-E J41	

SERVICE PROCEDURES

Turn the main switch off, and disconnect the negative battery lead. Secure the battery lead so it cannot contact the battery terminal, and remove the solenoid.

NOTE: Refer to the PARTS INFORMATION section to view all parts named in the following procedures.

DISASSEMBLY

1. Remove the cover screws and loosen the end cap.

CAUTION: Do not try to remove the cap of this point. The coil wires are still attached and will easily break if any strain is put on them.



DISASSEMBLY (Cont'd.)

2. Heat the terminals at the top of the cap to melt the solder that holds the coil wires. Only when the solder is fluid, pull upward on the cap and allow the wires to slip out. Discard the old cap and seal.

CAUTION: Do not pull on the end cap until the solder has melted. The coil wires will break.

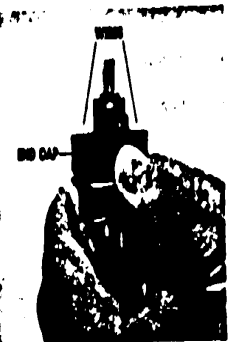

3. Remove the rubber cover, and underneath, the two screws, the plate, and the two coils.
4. Remove the contact plate by removing the small nut holding it to the shaft and plunger assembly.
5. Discard the plunger, shaft, and contact plate and parts. Keep the large spring and insulator for use in reassembly.



- REASSEMBLY**
- WARNING:** Failure to follow these reassembly and plunger adjustment instructions properly can cause the solenoid to engage by itself, with the following possible consequences:
- A. **ELECTRIC CAR - WITH BRAKE ON:** Overheating of the resistor coils and motor, resulting in serious damage to these components.
 - B. **ELECTRIC CAR - WITH BRAKE OFF:** The car may move without an operator.
 - C. **GAS CAR - WITH BRAKE ON OR OFF:** The starter motor will operate without the accelerator pedal being pressed. Under certain conditions, the car can move without an operator.

