



**YAMAHA**

**GENUINE**

**PARTS CATALOGUE**

**GOLF CAR**

# CYLINDER

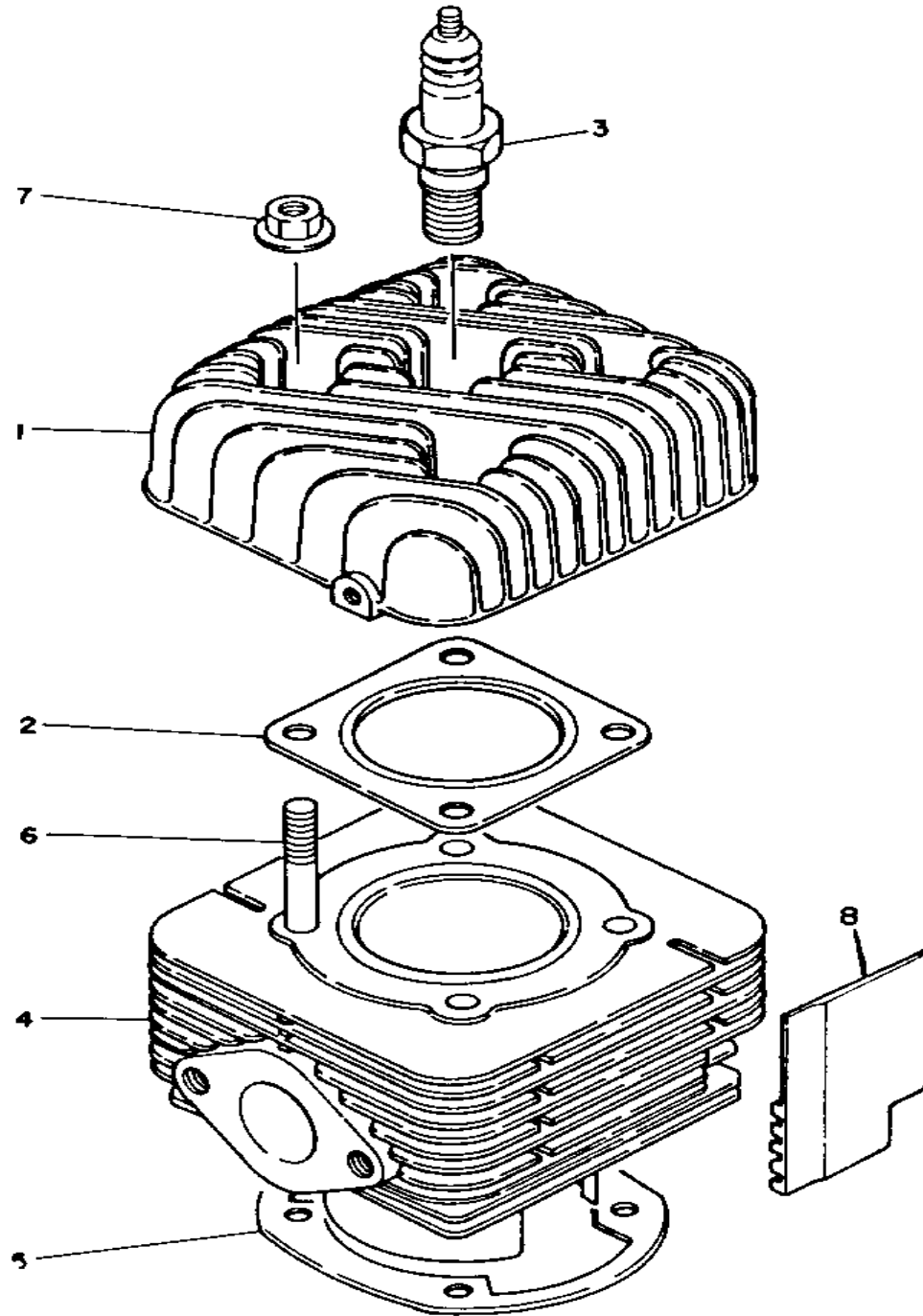

J24100-3010

Ref. No.	Part Number	Description	Qty	Remarks
1	J10-11111-00-00	HEAD, CYLINDER 1 .....	1	
2	J10-11181-00-00	GASKET, CYLINDER HEAD 1 .	1	
3	NGK-BP5HS-00-00	NGK BP5HS 10PK .....	1	
4	J10-11311-00-00	CYLINDER 1 .....	1	
5	881-11351-01-00	GASKET, CYLINDER .....	1	
6	90116-08079-00	BOLT, STUD .....	4	
7	95701-08500-00	NUT, FLANGE .....	4	
8	J24-11127-00-00	ABSORBER 3 .....	1	

# CRANKSHAFT - PISTON

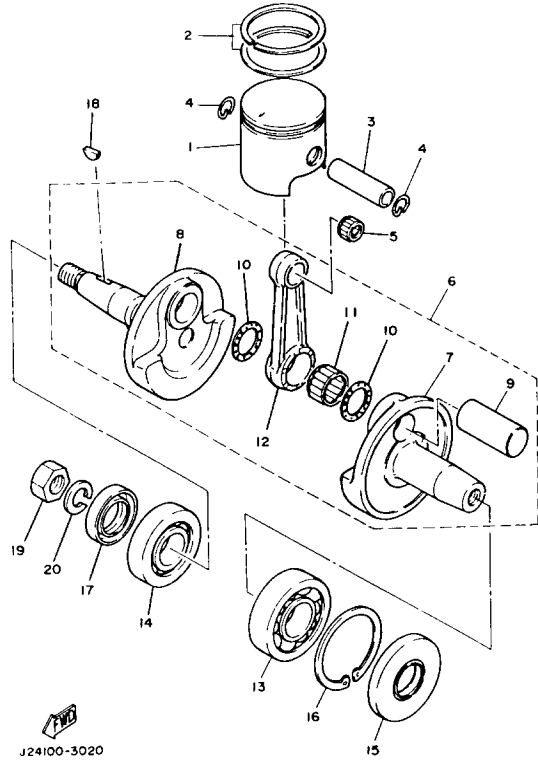

J24100-3020

Ref. No.	Part Number	Description	Qty	Remarks
1	J10-11631-00-96	PISTON STD	1	U.R.
	J10-11631-00-98	PISTON (STD)	1	U.R.
	J10-11635-00-00	PISTON 1 O/S 0.5	1	Alt. Part
	J10-11636-00-00	PISTON 2 O/S 0.0	1	Alt. Part
2	J10-11610-00-00	PISTON RINGSET STD	1	Alt. Part
	J10-11610-10-00	PISTON RINGSET 1ST (1ST O/S)	1	Alt. Part
	J10-11610-20-00	PISTON RINGSET 2ND (2ND O/S)	1	Alt. Part
3	818-11633-00-00	PIN, PISTON	1	
4	93450-20026-00	CIRCLIP	2	
5	93310-218A6-00	BEARING	1	
6	J10-11400-00-00	CRANKSHAFT ASSEMBLY	1	
7	J10-11412-00-00	. CRANK 1	1	
8	J10-11422-00-00	. CRANK 2	1	
9	857-11681-00-00	. PIN, CRANK 1	1	
10	90209-24073-00	. WASHER	2	
11	93310-42497-00	. BEARING, CYLINDER.# 0	1	
12	881-11651-00-00	. ROD, CONNECTING	1	
13	93306-30621-00	BEARING (B6306)	1	
14	93306-20622-00	BEARING	1	
15	93102-30188-00	OIL SEAL, SD-TYPE	1	
16	93450-72048-00	CIRCLIP, INNER	1	
17	93102-30128-00	OIL SEAL, SD-TYPE	1	
18	90280-16053-00	KEY, WOODRUFF	1	
19	90170-16182-00	NUT	1	
20	92901-16100-00	WASHER, SPRING	1	

# AIR SHROUD - FAN

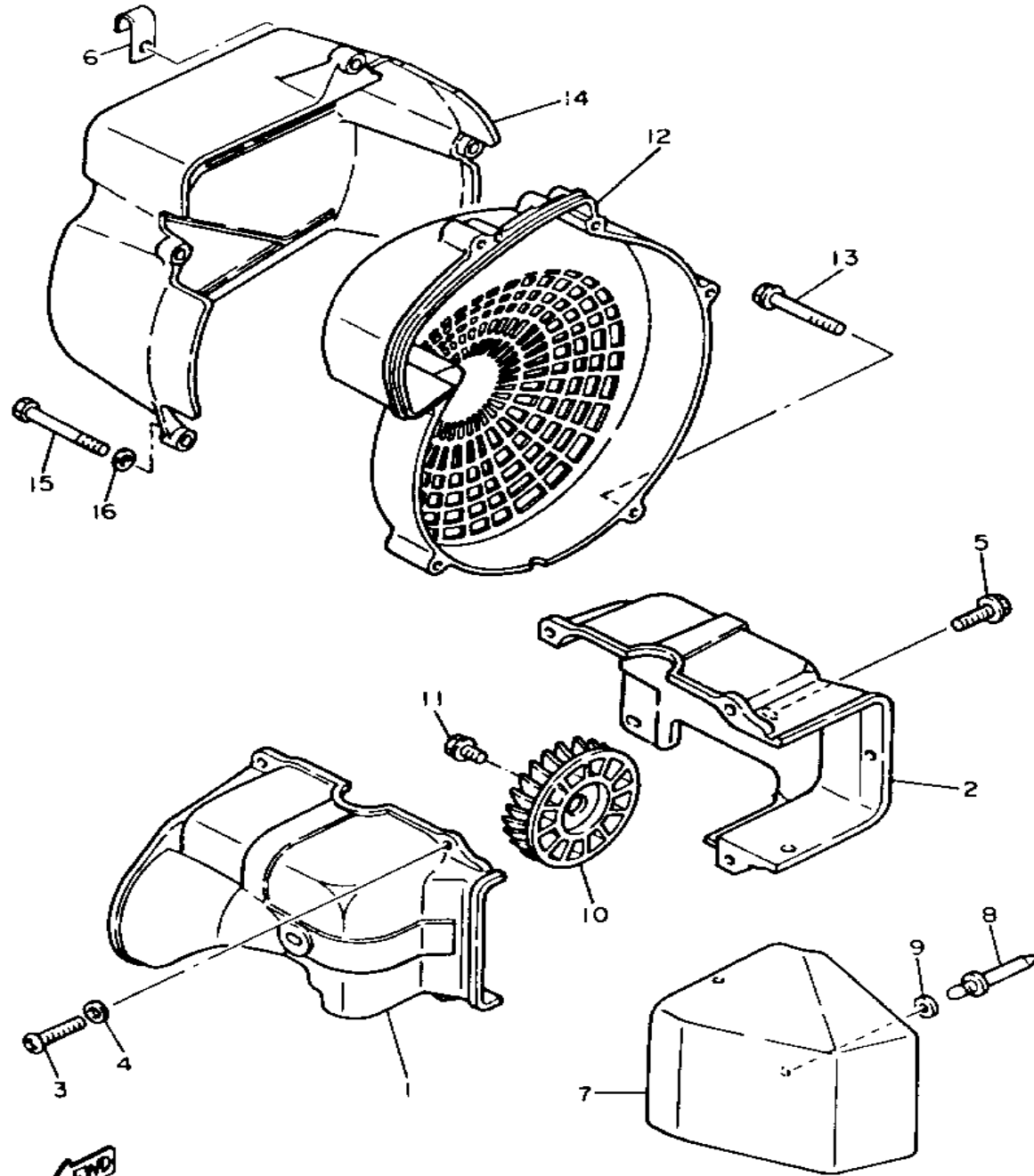

J31100-5030

Ref. No.	Part Number	Description	Qty	Remarks
1	J10-12651-00-00	AIR SHROUD, CYLINDER 1CYLINDER 1	1	
2	J24-12652-00-00	AIR SHROUD, CYLINDER 2CYLINDER 2	1	
3	98503-06014-00	SCREW, PAN HEAD (92502-06016)	5	
4	92990-06600-00	WASHER, PLATE	5	
5	90119-06108-00	BOLT, WITH WASHER	4	
6	90462-08056-00	CLAMP	1	
7	J10-12631-00-00	DEFLECTOR 1	1	
8	90267-48086-00	RIVET, BLIND	3	
9	90201-04325-00	WASHER, PLATE	3	
10	8G8-12611-01-00	FAN	1	
11	95811-06012-00	BOLT, FLANGE	6	
12	J10-12621-01-00	CASE, FAN	1	
13	95801-06050-00	BOLT, flange (95802-06050)	1	
14	J24-12616-00-00	COVER, FAN CASE	1	
15	97313-06060-00	BOLT, HEXAGON	4	
16	92990-06600-00	WASHER, PLATE	4	

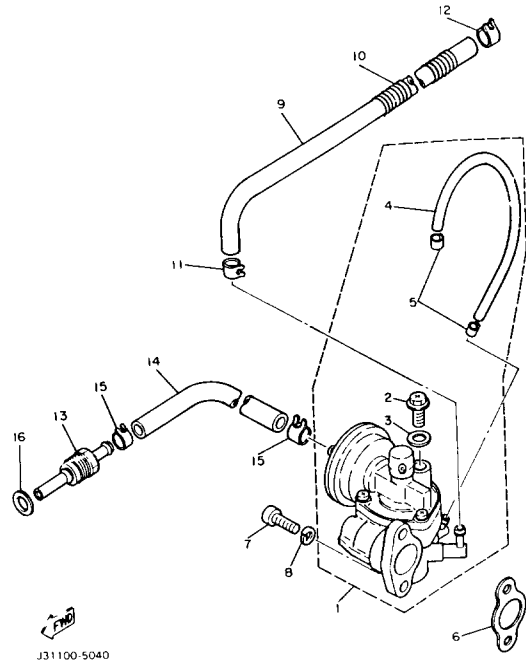

J31100-5040

## OIL PUMP

Ref. No.	Part Number	Description	Qty	Remarks
1	J24-13101-00-00	OIL PUMP ASSEMBLY .....	1	
2	90401-06001-00	. BOLT, UNION .....	1	
3	90430-06180-00	. GASKET .....	1	
4	90445-05214-00	. HOSE .....	1	
5	90468-02033-00	. CLIP .....	2	
6	8Y0-13116-01-00	GASKET, PUMP CASE .....	1	
7	98580-05016-00	SCREW, PAN HEAD .....	2	
8	92990-05100-00	WASHER, SPRING .....	2	
9	90445-09635-00	HOSE .....	1	
10	90501-08430-00	SPRING, COMPRESSION .....	1	
11	90467-09005-00	CLIP, SCISSOR .....	1	
12	90467-09026-00	CLIP .....	1	
13	J10-13283-00-00	JET, SENSER .....	1	
14	90445-11634-00	HOSE .....	1	
15	90467-10035-00	CLIP .....	2	
16	90201-08624-00	WASHER, PLATE .....	1	

# PUMP DRIVE - GEAR

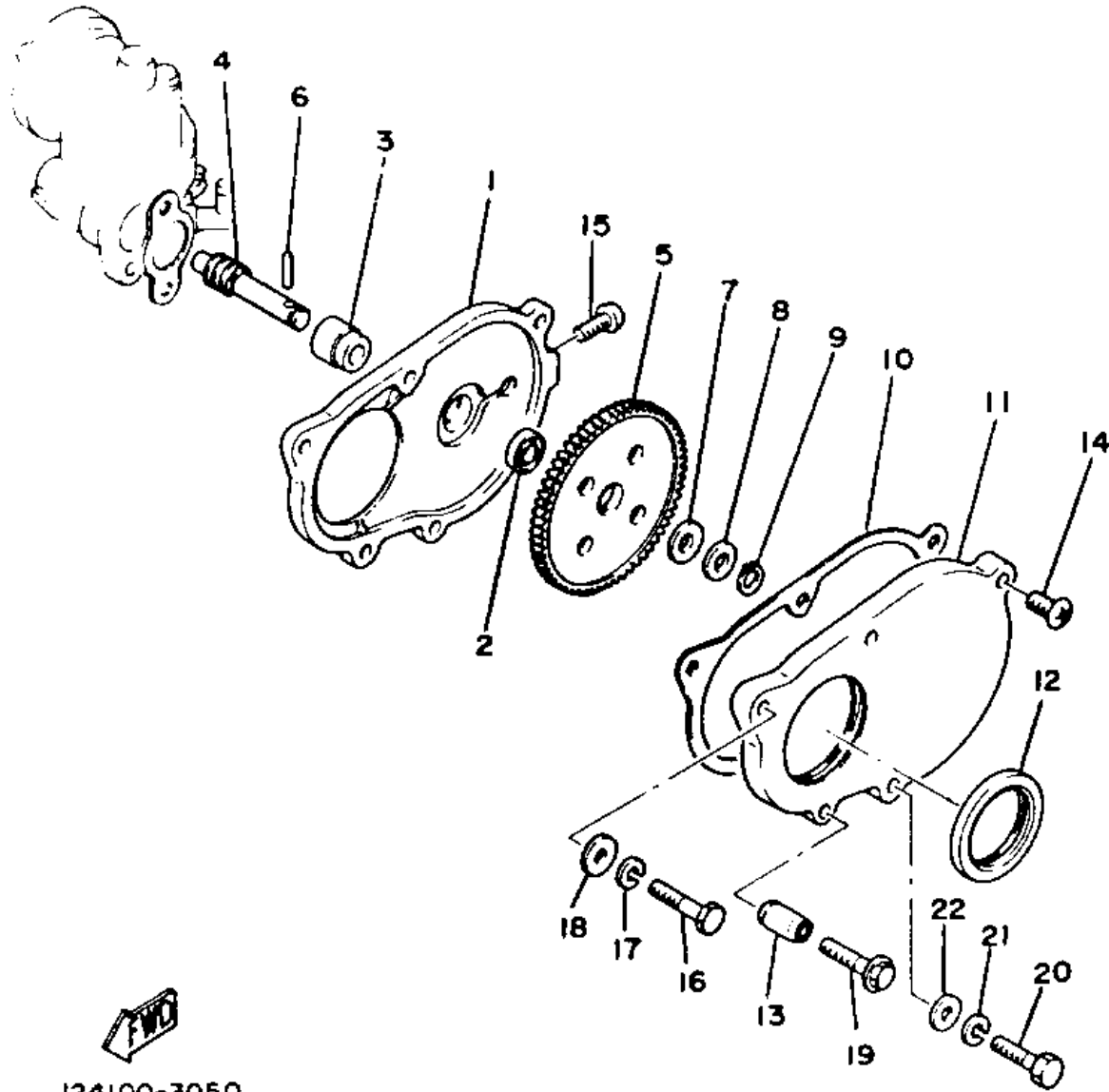

  
J24100-3050

Ref. No.	Part Number	Description	Qty	Remarks
1	J10-15416-00-00	COVER, OIL PUMP	1	
2	93101-10090-00	OIL SEAL	1	
3	1E7-13176-00-00	METAL, WRM SHAF OTR	1	
4	J10-13175-00-00	SHAFT, WORM	1	
5	J10-13188-00-00	GEAR, DRIVE	1	
6	93603-22028-00	PIN, DOWEL	1	
7	90206-11016-00	WASHER, WAVE	1	
8	137-13148-00-00	PLATE, CAM THRUST	1	
9	99009-10400-00	CIRCLIP	1	
10	J10-15466-00-00	GASKET 2	1	
11	J10-15426-00-00	COVER, OIL PUMP R	1	
12	93112-53004-00	OIL SEAL, SR-TYPE	1	
13	91810-18025-00	PIN, DOWEL	2	
14	98503-06018-00	SCREW, pan head (92503-06018-00)	1	
15	98580-06012-00	SCREW, PAN HEAD	1	
16	97313-08035-00	BOLT, HEXAGON	1	
17	92990-08100-00	WASHER	1	
18	92990-08600-00	WASHER, PLATE	1	
19	95822-06035-00	BOLT, flange	2	
20	97021-06030-00	BOLT	1	
21	92995-06100-00	WASHER, SPRING	1	
22	92990-06600-00	WASHER, PLATE	1	

# AIR FILTER

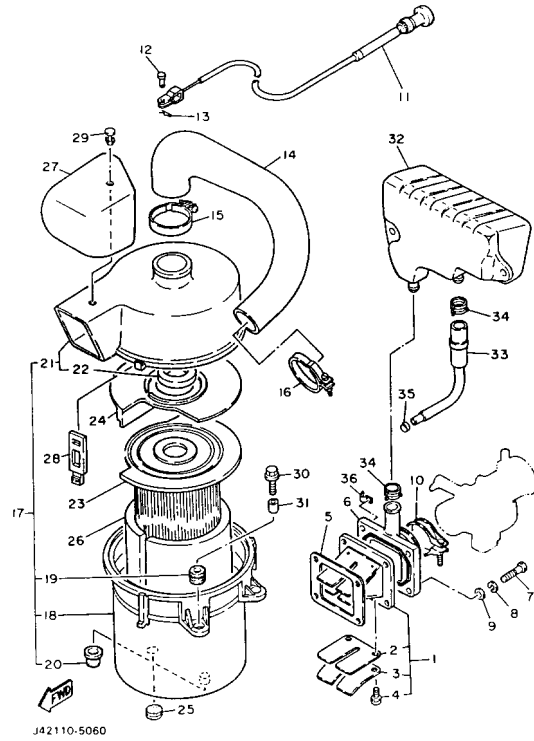

J42110-5060

Ref. No.	Part Number	Description	Qty	Remarks
1	10V-13610-01-00	REED VALVE ASSEMBLY (885-13610-00)	1	
2	10V-13613-01-00	. REED, VALVE (1L8-13613-00)	2	
3	1UA-13616-00-00	. STOPPER REED VALVE VALVE (10V-13616-01)	2	
4	98580-03008-00	. SCREW, PAN HEAD	4	
5	3TT-13621-00-00	GASKET, VALVE SEAT	1	
6	J24-13586-00-00	JOINT, CARBURETOR 1	1	
7	97021-06030-00	BOLT	4	
8	92995-06100-00	WASHER, SPRING	4	
9	92990-06600-00	WASHER, PLATE	4	
10	90460-41191-00	CLAMP, HOSE (90460-41146)	1	
11	J42-26331-00-00	CABLE, starter 1	1	
12	91701-05010-00	PIN, CYLINDER. HEAD	1	
13	90468-10050-00	CLIP	1	
14	J10-14453-00-00	JOINT, AIR CLNR 1	1	
15	1HX-13575-00-00	BAND	1	
16	90460-53239-00	CLAMP, HOSE	1	
17	J17-14410-00-00	AIR CLEANER ASSEMBLY 1	1	
18	J10-14411-00-00	. CASE, air cleaner 1	1	
19	90480-13238-00	. GROMMET	2	
20	90480-14239-00	. GROMMET	2	
21	J17-14412-00-00	. CAP, cleaner case 1	1	
22	J10-14416-00-00	. GASKET, AIR CLEANER	1	
23	J10-14450-10-00	ELEMENT ASS'Y, air cleaner	1	
24	J10-1441F-00-00	PARTN, AIR CLNR CSAIR CLEANER CASE	1	
25	90480-14100-00	GROMMET	1	
26	J10-14417-00-00	COVER 1	1	
27	J17-12644-00-00	DEFLECTOR 3	1	

CONTINUED ON NEXT FRAME ►

# AIR FILTER

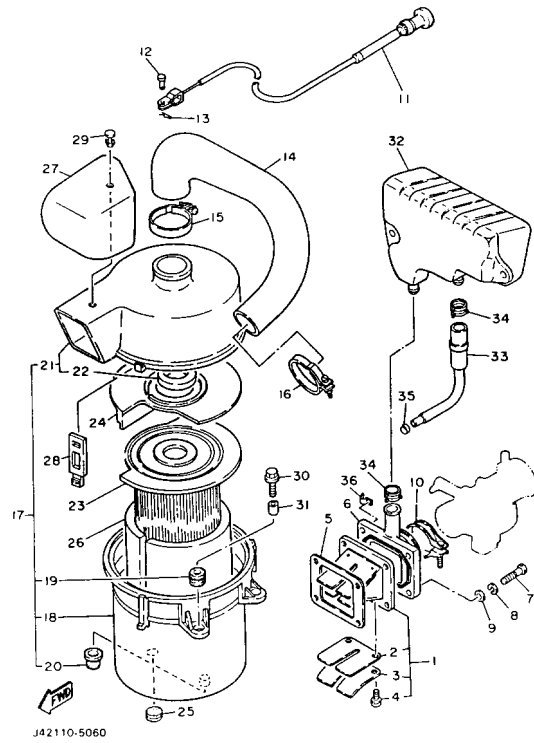

Ref. No.	Part Number	Description	Qty	Remarks
28	J10-14436-00-00	HOOK .....	3	
29	90269-65032-00	RIVET, SPEC'L SHAPE .....	1	
30	90119-06097-00	BOLT, WITH WASHER .....	2	
31	90387-06026-00	COLLAR .....	2	
32	J24-13581-00-00	CHAMBER, AIR .....	1	
33	J24-14388-00-00	VALVE, VAC CONTROL .....	1	
34	90468-08104-00	CLIP .....	2	
35	90468-02025-00	CLIP .....	1	
36	90462-08056-00	CLAMP .....	1	

# CARBURETOR

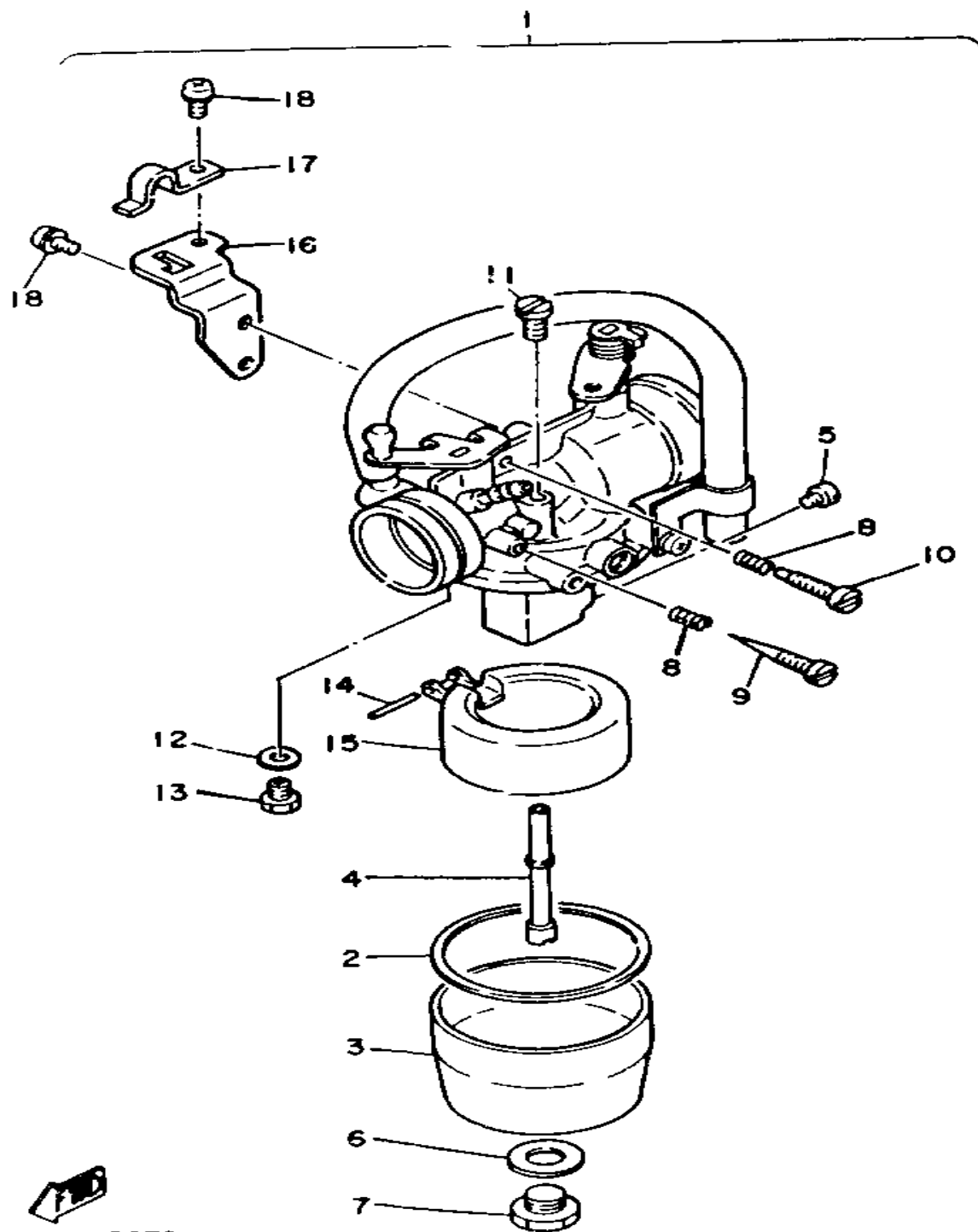

J24100-3070

Ref. No.	Part Number	Description	Qty	Remarks
1	J24-14101-01-00	CARBURETOR 1 (J24-14101-00)	1	
2	796-14184-00-00	. GASKET, FLOAT CHAMBER .	1	
3	796-14181-00-00	. BODY, FLOAT CHMBR 1 . . . .	1	
4	J17-14141-00-00	. NOZZLE, MAIN . . . . .	1	
5	3G2-14231-19-00	. JET, POWER (# 95) . . . . .	1	
6	732-14237-00-00	. GASKET . . . . .	1	
7	J10-14244-00-00	. HOLDER, NOZZLE . . . . .	1	
8	620-14212-00-00	. SPRING, PILOT ADJUSTING .	2	
9	620-14211-00-00	. SCREW, PILOT ADJUSTING .	1	
10	J10-14122-00-00	. SCREW, THROTTLE . . . . .	1	
11	620-1414J-15-00	. JET, PILOT . . . . .	1	
12	127-14195-00-00	. WASHER, NEEDLE VALVE . .	1	
13	353-14190-10-00	. NEEDLE VALVE ASSEMBLY .	1	
14	796-14186-00-00	. PIN, FLOAT . . . . .	1	
15	796-14185-00-00	. FLOAT . . . . .	1	
16	J10-14581-00-00	. BRACKET . . . . .	1	
17	J10-14243-00-00	. PLATE . . . . .	1	
18	98580-03008-00	. SCREW, PAN HEAD . . . . .	2	
	J10-14131-00-00	SPRING, THROTTLE . . . . .	1	OPTIONAL PART
	J24-14202-09-00	THROTTLE SHAFT ASSEMBLY	1	OPTIONAL PART

# EXHAUST

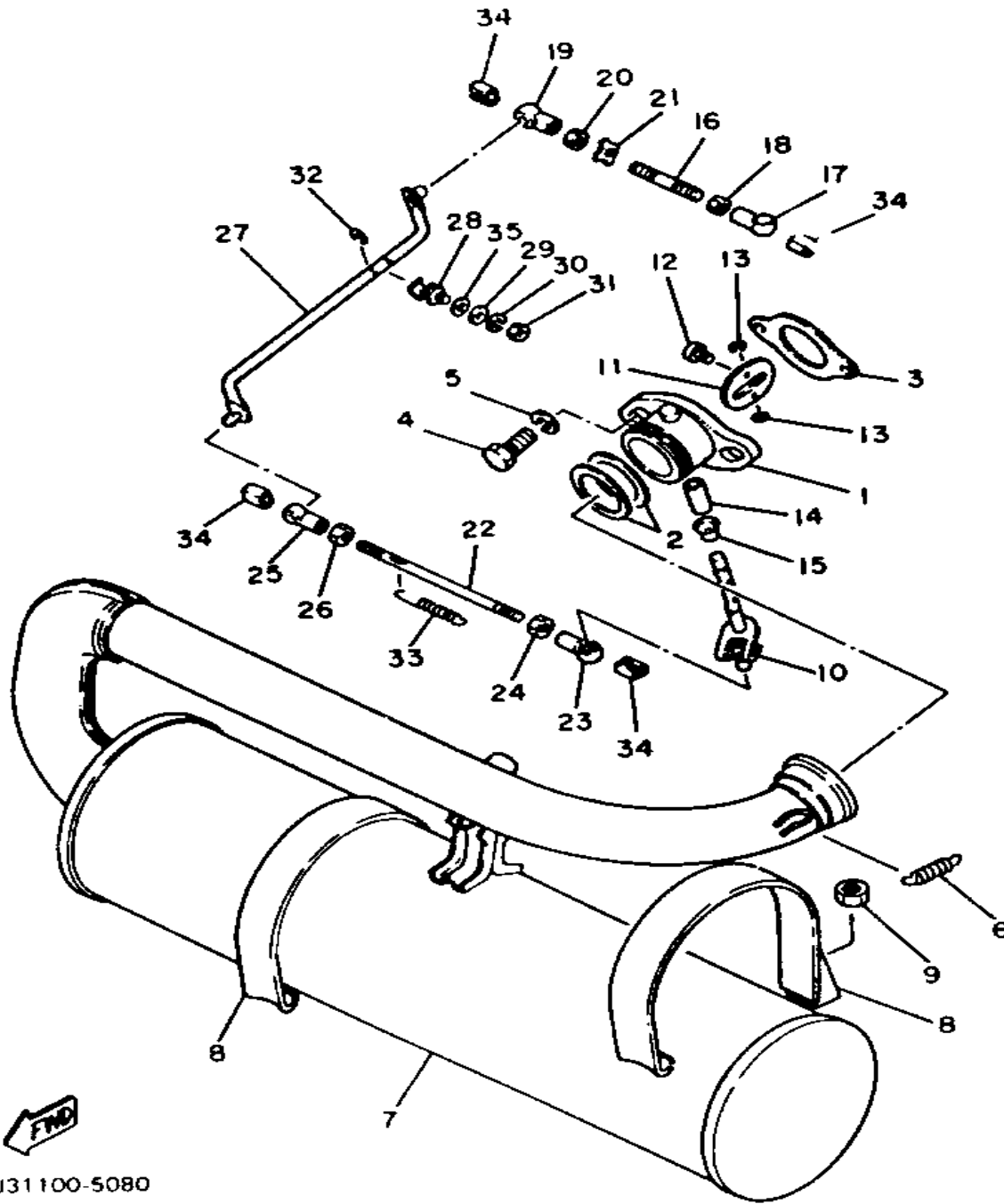

J31100-5080

Ref. No.	Part Number	Description	Qty	Remarks
1	J24-14612-00-00	NUT, RING .....	1	
2	888-14633-00-00	RING .....	2	
3	J10-14613-00-00	GASKET, EXST PIPE .....	1	
4	97013-08025-00	BOLT .....	2	
5	92990-08100-00	WASHER .....	2	
6	90506-20074-00	SPRING, TENSION .....	2	
7	J24-14610-00-00	EXHAUST PIPE ASSEMBLY L .	1	
8	J10-14715-01-00	BAND, MUFFLER .....	2	
9	95611-08100-00	NUT, U .....	2	
10	J10-14813-01-00	SHAFT, BUTTERFLY .....	1	
11	J10-14812-02-00	VALVE, BUTTERFLY .....	1	
12	98580-03008-00	SCREW, PAN HEAD .....	2	
13	99080-05600-00	CIRCLIP .....	2	
14	J10-14815-00-00	GASKET .....	1	
15	J10-14818-00-00	COVER, GASKET .....	1	
16	J10-14836-00-00	ROD .....	1	
17	J10-14833-01-00	JOINT .....	1	
18	95301-05700-00	NUT (95302-05700) .....	1	
19	J10-14864-01-00	JOINT .....	1	
20	90170-05190-00	NUT, HEXAGON .....	1	
21	J24-14842-00-00	PLATE, CON ROD .....	1	
22	J10-14837-00-00	CONNECTOR, ROD .....	1	
23	J10-14833-01-00	JOINT .....	1	
24	95301-05700-00	NUT (95302-05700) .....	1	
25	J10-14864-01-00	JOINT .....	1	
26	90170-05190-00	NUT, HEXAGON .....	1	
27	J10-14802-00-00	CONNECTER COMP .....	1	
28	90464-07034-00	CLAMP .....	2	
29	92901-05600-00	WASHER, PLATE .....	2	

CONTINUED ON NEXT FRAME ►

# EXHAUST

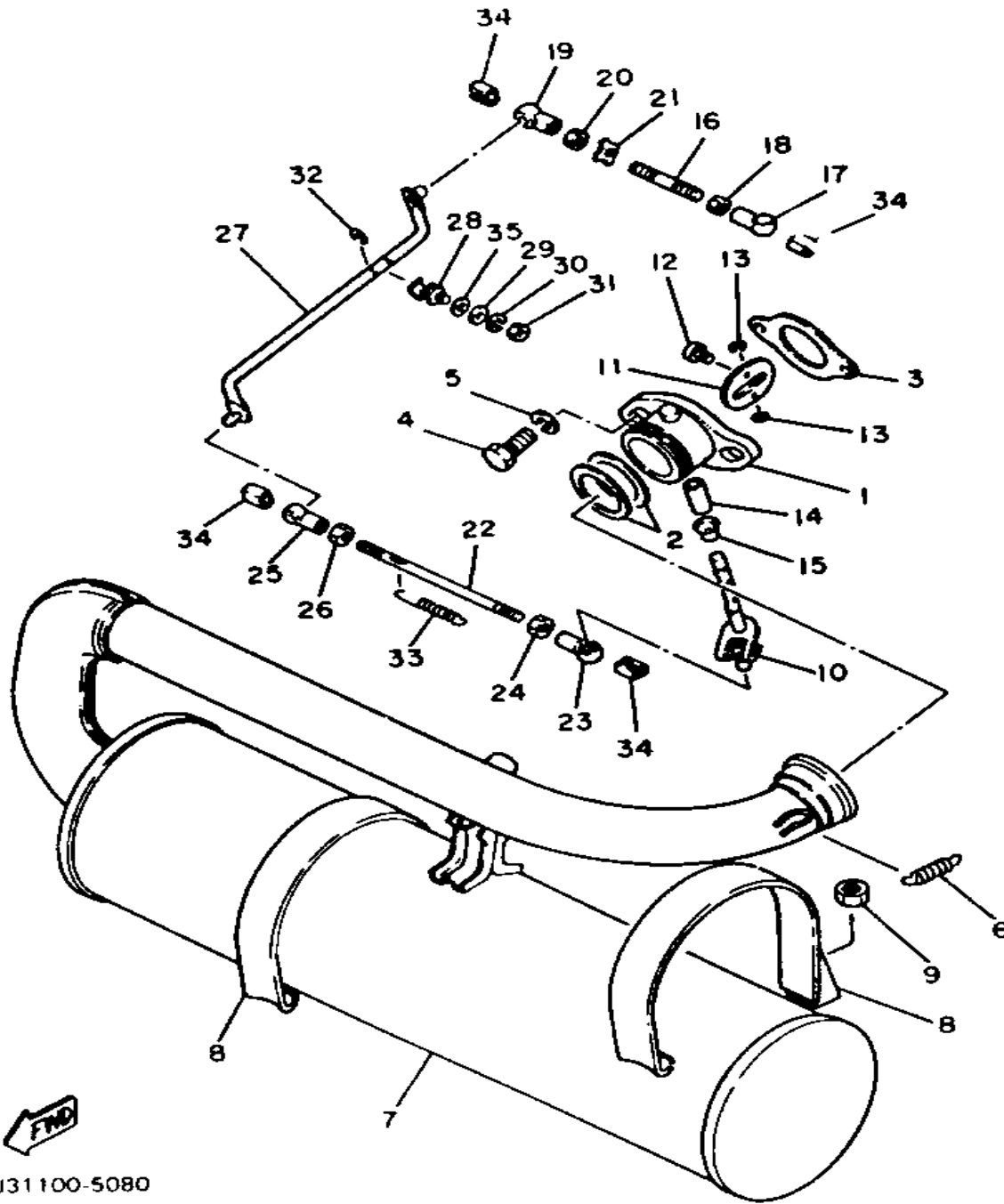

J31100-5080

Ref. No.	Part Number	Description	Qty	Remarks
30	92990-05100-00	WASHER, SPRING .....	2	
31	95301-05600-00	NUT .....	2	
32	99009-06600-00	CIRCLIP .....	2	
33	90506-06201-00	SPRING, TENSION .....	1	
34	J24-14846-00-00	BOOT, ACTUATOR .....	4	
35	92990-05200-00	WASHER, PLAIN .....	2	

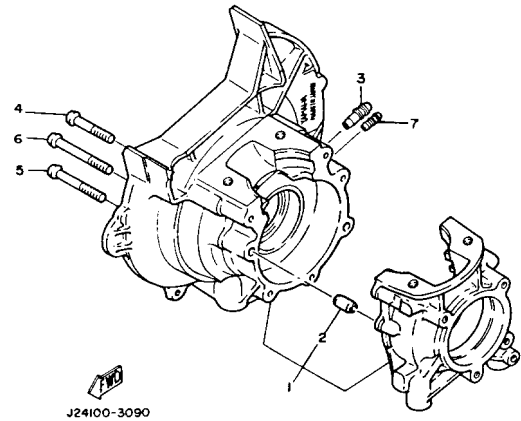

## CRANKCASE

Ref. No.	Part Number	Description	Qty	Remarks
1	J24-15100-00-00	CRANKCASE ASSEMBLY	1	
2	99530-10014-00	. PIN, DOWEL	2	
3	J38-11116-00-00	JOINT, BREATHER	1	
4	92503-06045-00	SCREW, PAN HEAD	5	
5	90157-06072-00	SCREW, PAN HEAD	1	
6	98580-06055-00	SCREW, pan head (92501-06065-00)	1	
7	18A-15138-00-00	NOZZLE 1	1	

# REAR SHOCKS

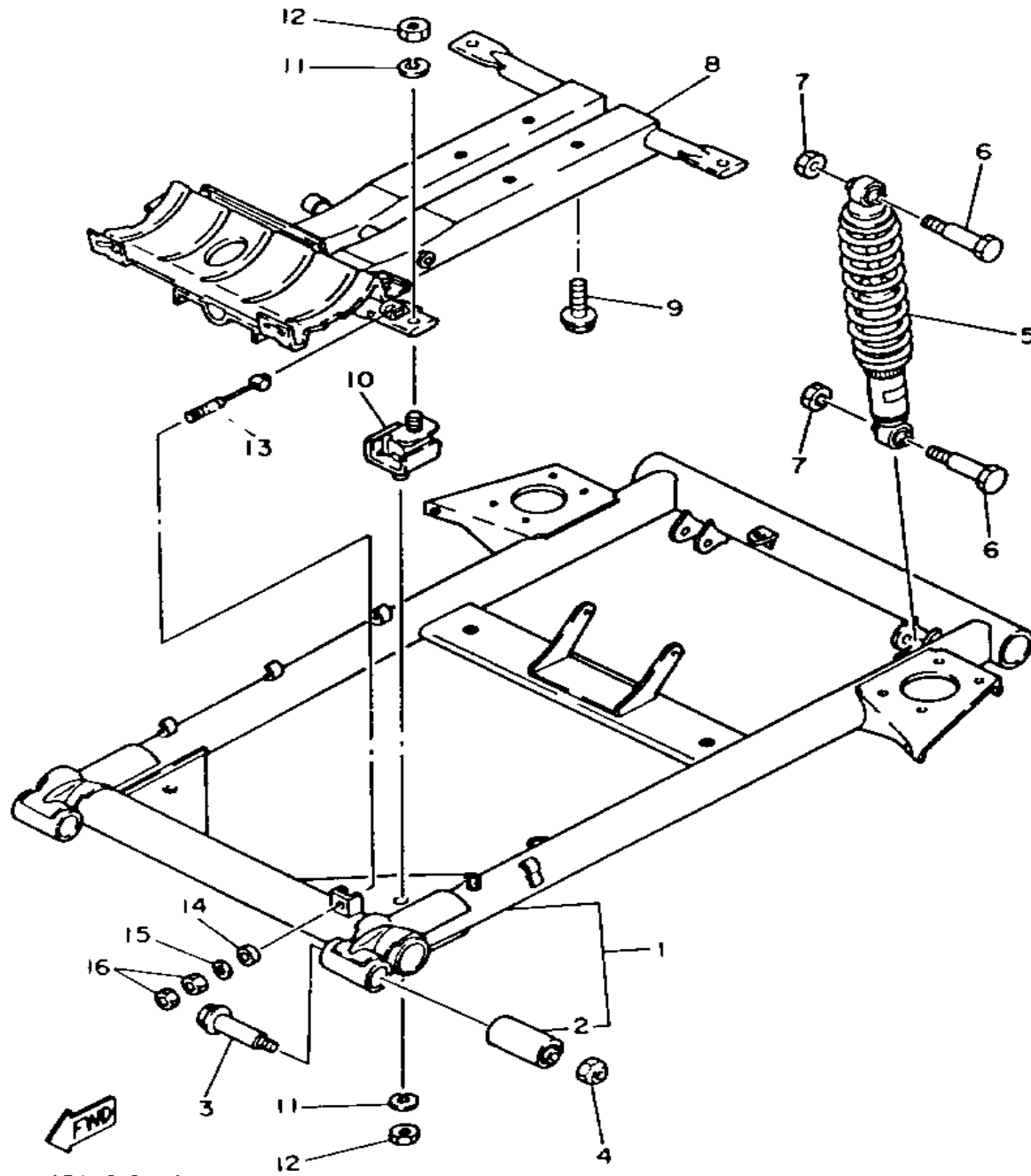

Ref. No.	Part Number	Description	Qty	Remarks
1	(J42-Y2210-00-00)	REAR ARM COMP. ....	1	
2	J10-22123-00-00	. BUSH 1 .....	2	
3	90105-10359-00	BOLT, WASHER BASED .....	2	
4	90185-10130-00	NUT, self-locking .....	2	
5	J46-22210-00-00	SHOCK ABSORBER ASS'Y, rear (J42-22210-00-00) .....	2	
6	97313-10050-00	BOLT, HEXAGON (676) .....	4	
7	95601-10100-00	NUT, U (95602-10100-00) .....	4	
8	J17-21411-00-00	BRACKET, ENGINE 1 .....	1	
9	95822-10025-00	BOLT, FLANGE .....	4	
10	J10-21486-00-00	DAMPER 2 .....	4	
11	92990-10100-00	WASHER, SPRING .....	8	
12	95303-10700-00	NUT .....	8	
13	J31-2217J-01-00	TENSIONER 1 .....	1	
14	J17-2214F-00-00	DAMPER 1 .....	1	
15	90201-06778-00	WASHER, PLATE .....	1	
16	95380-06600-00	NUT .....	2	

# FRAME

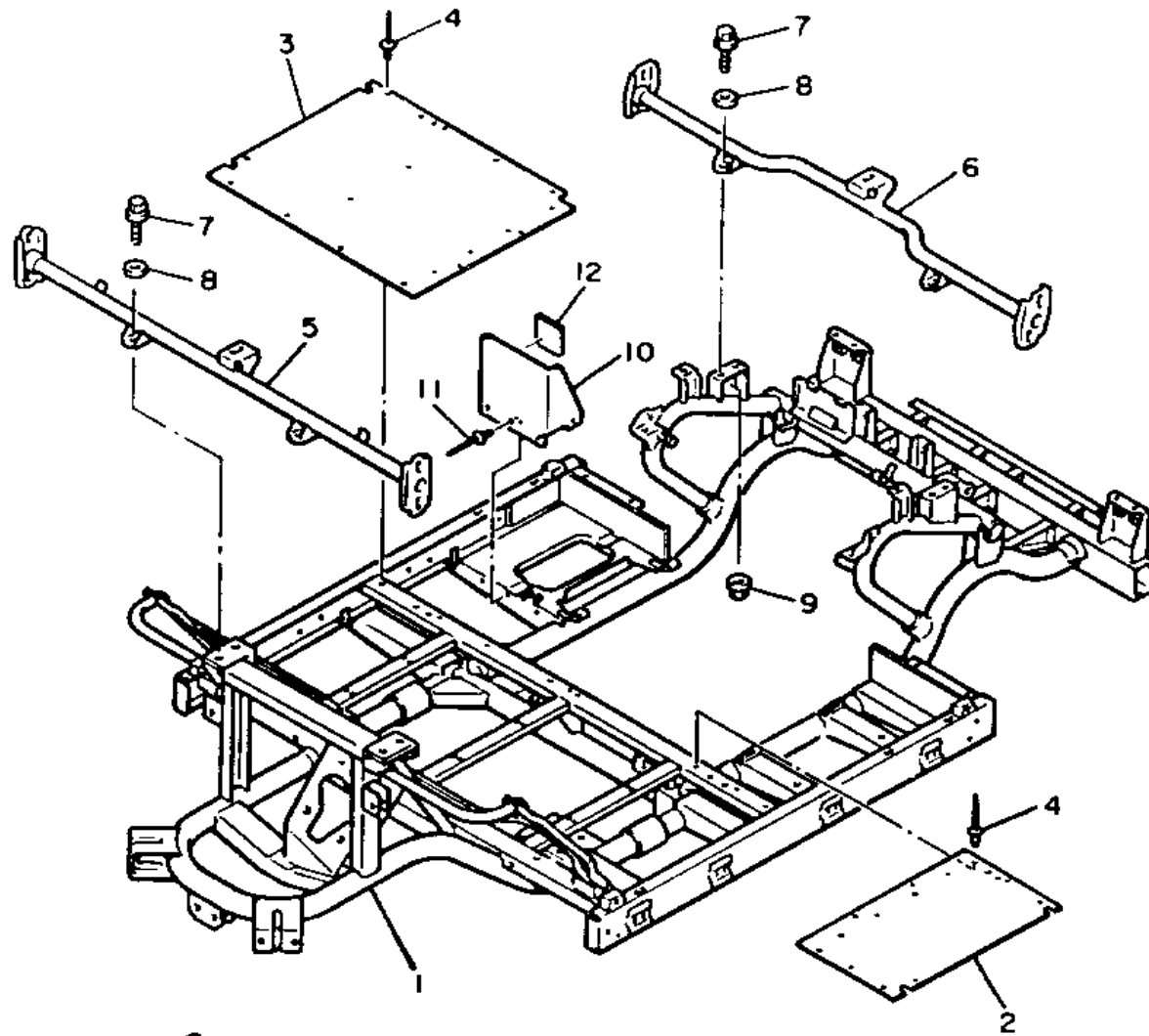

Ref. No.	Part Number	Description	Qty	Remarks
1	J42-22501-00-00	FRAME COMP .....	1	
2	J42-22571-00-00	PANEL 1 .....	1	
3	J42-22572-00-00	PANEL 2 .....	1	
4	90267-40054-00	RIVET, BLIND .....	18	
5	J42-2254J-01-00	SUPPORT, side panel .....	1	
6	J42-2254K-00-00	SUPPORT, side panel 2 .....	1	
7	95821-08020-00	BOLT, FLANGE (95801-08020) .	8	
8	90201-084K3-00	WASHER, PLATE .....	8	
9	95701-08500-00	NUT, FLANGE .....	4	
10	J24-2255V-00-00	PLATE, BATT COVER .....	1	
11	ø90-26732-06-30	UNAVAILABLE IN PRICE BOOK	4	
12	J24-2255Y-00-00	PAD, BATT COVER .....	1	



J42110-5120

# FRONT SUSPENSION - WHEEL

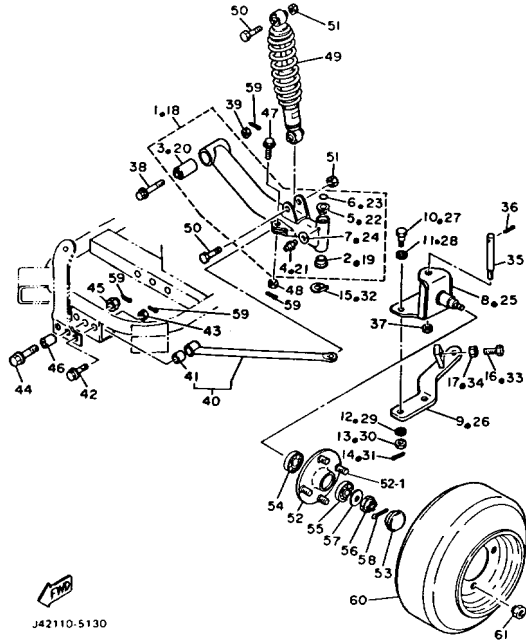

J42110-5130

Ref. No.	Part Number	Description	Qty	Remarks
1	J42-W2351-00-00	FRONT LOWER ARM LHCOMP. (L.H)	1	
2	90381-15032-00	. BUSH, SOLID	1	
3	J10-23526-00-00	. BUSH	1	
4	93700-06004-00	. NIPPLE, GREASE	1	
5	90381-15040-00	. BUSH, SOLID	1	
6	93210-15566-00	. O-RING	1	
7	90201-067F9-00	. WASHER, PLATE	1	
8	J17-23510-00-00	KNUCKLE, STEERING 1	1	
9	J11-23512-00-00	ARM, KNUCKLE 1	1	
10	90109-10643-00	BOLT	2	
11	90201-121F0-00	WASHER, PLATE	2	
12	90201-105F2-00	WASHER, PLATE	2	
13	90171-10035-00	NUT, CASTLE	2	
14	91490-25030-00	PIN, COTTER	2	
15	90214-16027-00	WASHER, CLAW	1	
16	97313-08030-00	BOLT, HEXAGON	1	
17	95303-08700-00	NUT	1	
18	J42-W2352-00-00	FRONT LOWER ARM RHCOMP (R.H)	1	
19	90381-15032-00	. BUSH, SOLID	1	
20	J10-23526-00-00	. BUSH	1	
21	93700-06004-00	. NIPPLE, GREASE	1	
22	90381-15040-00	. BUSH, SOLID	1	
23	93210-15566-00	. O-RING	1	
24	90201-067F9-00	. WASHER, PLATE	1	
25	J17-23510-00-00	KNUCKLE, STEERING 1	1	
26	J11-23522-00-00	ARM, KNUCKLE 2	1	
27	90109-10643-00	BOLT	2	

CONTINUED ON NEXT FRAME ►

# FRONT SUSPENSION - WHEEL

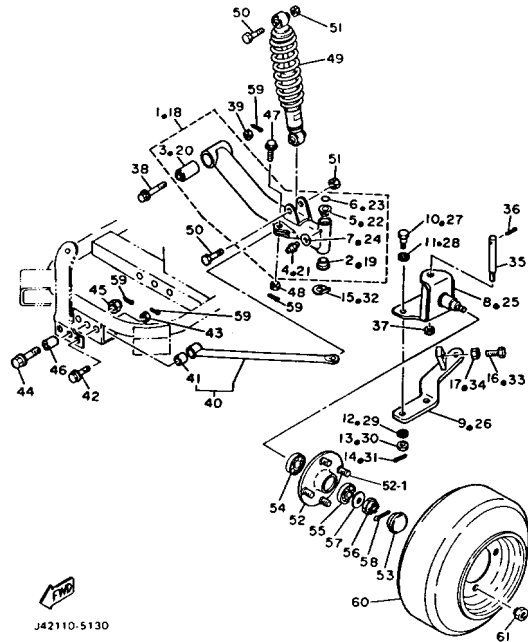

J42110-5130

Ref. No.	Part Number	Description	Qty	Remarks
28	90201-121F0-00	WASHER, PLATE .....	2	
29	90201-105F2-00	WASHER, PLATE .....	2	
30	90171-10035-00	NUT, CASTLE .....	2	
31	91490-25030-00	PIN, COTTER .....	2	
32	90214-16027-00	WASHER, CLAW .....	1	
33	97313-08030-00	BOLT, HEXAGON .....	1	
34	95303-08700-00	NUT .....	1	
35	J10-23516-02-00	KING PIN, STRG KNKL .....	2	
36	91401-30030-00	PIN, COTTER .....	2	
37	95701-12300-00	NUT, nylon (95702-12300) ....	2	
38	90105-10224-00	BOLT, WASHER BASED .....	2	
39	95601-10200-00	NUT, SELF-LOCKING .....	2	
40	J17-W2355-00-00	ROD, TENSION .....	2	
41	J10-23583-01-00	. BUSH .....	1	
42	90105-08225-00	BOLT, WASHER BASED .....	2	
43	95601-08200-00	NUT, U .....	2	
44	95812-12050-00	BOLT, flange .....	1	
45	95701-12500-00	NUT, FLANGE .....	1	
46	90387-137F6-00	COLLAR .....	1	
47	90102-12046-00	BOLT, WITH HOLE .....	2	
48	95601-12200-00	NUT, SELF-LOCKING .....	2	
49	J42-23350-00-00	SHOCK ABSORBER ASSEMBLY (J10-23350-00) ...	4	
50	97313-10050-00	BOLT, HEXAGON (676) .....	4	
51	95612-10100-00	NUT, BIND .....	4	
52	J17-W2511-00-00	HUB, FRONT .....	2	
53	J17-25118-00-00	COVER, HUB DUST .....	2	
54	93306-00511-00	BEARING .....	2	
55	93306-20437-00	BEARING .....	2	

CONTINUED ON NEXT FRAME ►

# FRONT SUSPENSION - WHEEL

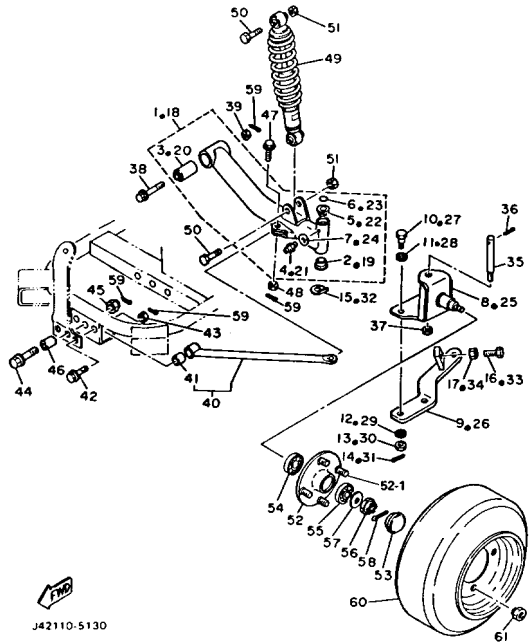

J42110-5130

Ref. No.	Part Number	Description	Qty	Remarks
56	95301-14900-00	NUT, SLOTTED .....	2	
57	90209-14219-00	WASHER, SPEC'L SHAP ....	2	
58	91401-30030-00	PIN, COTTER .....	2	
59	91490-25030-00	PIN, COTTER .....	6	
60	*---	FRONT WHEEL ASSEMBLY ..	2	LM (See Note)
61	90179-12262-00	NUT .....	8	
52-1	90114-12003-00	. BOLT, RIBBED NECK .....	8	

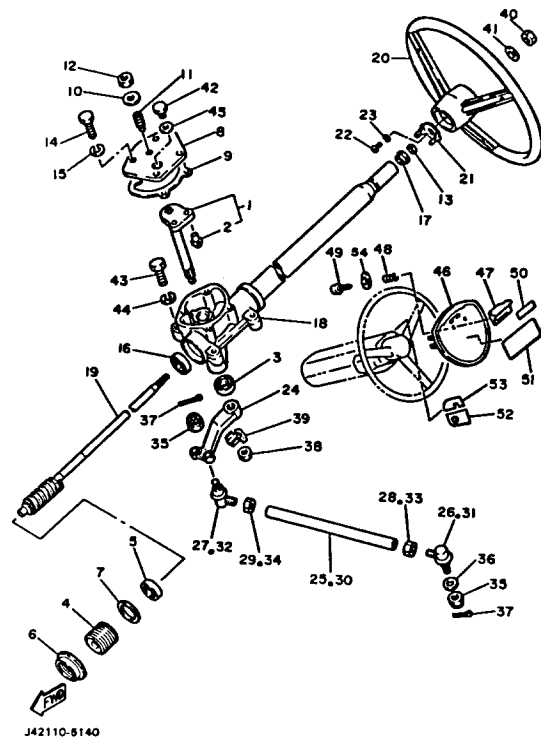

## STEERING

Ref. No.	Part Number	Description	Qty	Remarks
1	J24-23816-01-00	ARM, PITMAN (J24-23816-00)	1	
2	J10-23836-09-00	. PIN, PITMAN	2	
3	93102-22087-00	OIL SEAL	1	
4	J55-F3876-00-00	BOLT	1	
5	93332-00010-00	BEARING	1	
6	J10-23877-00-00	NUT	1	
7	J10-23444-00-00	WASHER	1	
8	J10-23818-00-00	COVER, STEERING	1	
9	J10-23462-00-00	SEAL, STEERING	1	
10	90201-08087-00	WASHER, PLATE	1	
11	J10-23459-00-00	BOLT	1	
12	90170-08024-00	NUT, HEX.	1	
13	93104-15005-00	OIL SEAL, SO-TYPE	1	
14	97313-08020-00	BOLT, HEXAGON	4	
15	92990-08100-00	WASHER	4	
16	93332-00010-00	BEARING	1	
17	J42-23814-00-00	HOLDER, handle upper	1	
18	J42-23811-00-00	COLUMN, steering	1	
19	J10-23840-00-00	STEERING SHAFT	1	
20	J50-F3838-00-00	WHEEL, STEERING	1	
21	J42-23839-00-00	PIN, CANCEL	1	
22	98580-04008-00	SCREW, PAN HEAD	3	
23	92901-04600-00	WASHER, PLATE	3	
24	J24-23826-00-00	ARM, IDLER	1	
25	J10-23831-00-00	ROD, TIE	1	
26	J10-23841-10-00	JOINT, UNIVERSAL 1	1	
27	J10-23845-10-00	JOINT, UNIVERSAL 2	1	
28	90170-12054-00	NUT	1	
29	90170-12055-00	NUT	1	

CONTINUED ON NEXT FRAME ►

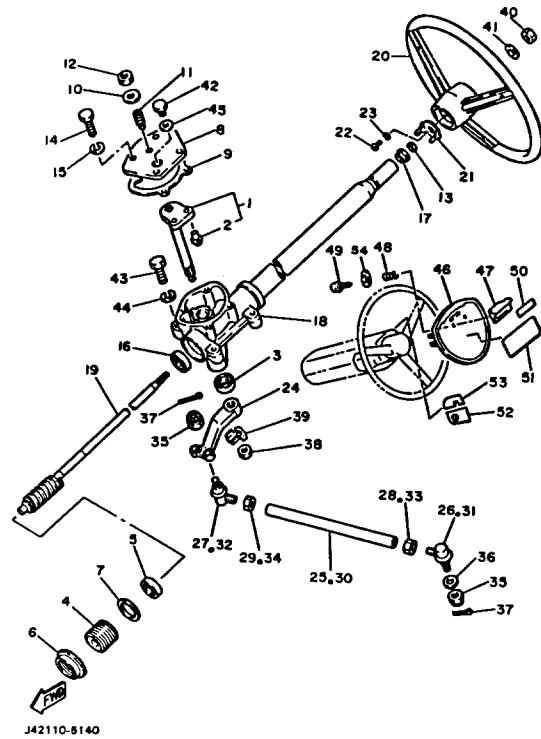

## STEERING

Ref. No.	Part Number	Description	Qty	Remarks
30	J10-23831-00-00	ROD, TIE .....	1	
31	J10-23841-10-00	JOINT, UNIVERSAL 1 .....	1	
32	J10-23845-10-00	JOINT, UNIVERSAL 2 .....	1	
33	90170-12054-00	NUT .....	1	
34	90170-12055-00	NUT .....	1	
35	95301-12900-00	NUT, SLOTTED .....	4	
36	92990-12600-00	WASHER, PLATE .....	2	
37	91401-30030-00	PIN, COTTER .....	4	
38	95701-16300-00	NUT, FLANGE .....	1	
39	90215-16161-00	WASHER, LOCK .....	1	
40	90185-12119-00	NUT, SELF-LOCKING .....	1	
41	92990-12200-00	WASHER, PLAIN .....	1	
42	90340-14029-00	PLUG, STRAIGHT SCREW ....	1	
43	97313-10050-00	BOLT, HEXAGON (676) .....	4	
44	92990-10100-00	WASHER, SPRING .....	4	
45	90430-14175-00	GASKET .....	1	
46	J50-K8357-00-00	HOLDER 1 .....	1	
47	J50-K8358-00-00	HOLDER 2 .....	1	
48	90502-10013-00	SPRING, CONICAL .....	2	
49	97780-50125-00	SCREW, TAPPING .....	2	
50	J10-78292-00-00	EMBLEM 2 .....	1	
51	J42-77762-00-00	LABEL, warning 2 .....	1	
52	J42-77741-00-00	INDICATOR 1 .....	1	
53	J42-77742-00-00	INDICATOR 2 .....	1	
54	92901-05600-00	WASHER, PLATE .....	2	

# OIL TANK

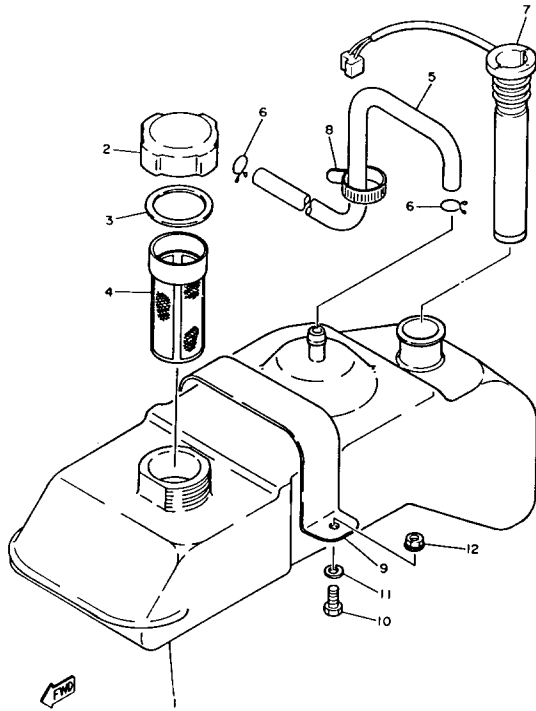

Ref. No.	Part Number	Description	Qty	Remarks
1	J42-21751-00-00	TANK, oil .....	1	
2	863-21771-00-00	BODY, CAP .....	1	
3	90430-31003-00	GASKET .....	1	
4	J17-21756-00-00	NET, FILTER .....	1	
5	J10-21745-00-00	PIPE, OIL TNK BRTHR .....	1	
6	90467-11009-00	CLIP .....	2	
7	J42-85720-00-00	OIL LEVEL GAUGE ASS'Y ...	1	
8	25G-83936-01-00	BAND, SWITCH CORD .....	1	
9	J17-21776-00-00	BAND, TANK FITTING .....	1	
10	97313-06016-00	BOLT, HEXAGON .....	2	
11	90201-063J2-00	WASHER, PLATE .....	2	
12	95601-06200-00	NUT, U FLANGE .....	2	

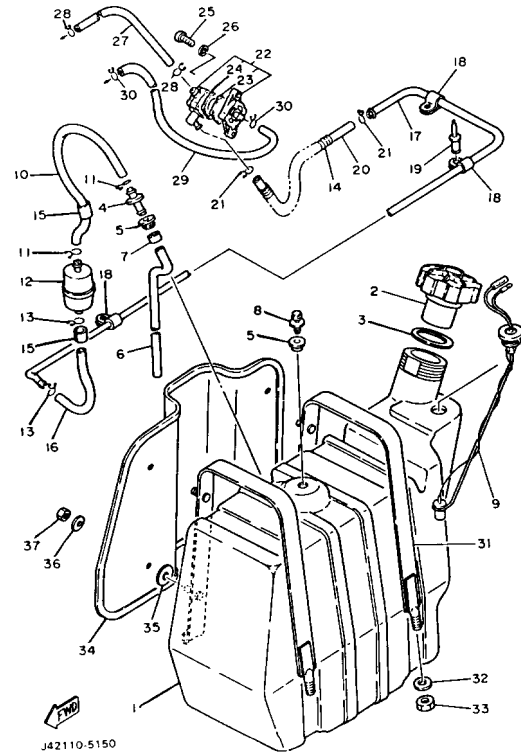

# FUEL TANK

Ref. No.	Part Number	Description	Qty	Remarks
1	J17-24111-00-00	FUEL TANK	1	
2	J24-24620-01-00	BODY CAP ASSEMBLY	1	
3	J10-24612-00-00	GASKET, CAP	1	
4	J10-24461-00-00	PIPE, JOINT	1	
5	J10-21773-00-00	GROMMET	2	
6	J10-24311-00-00	PIPE, FUEL 1	1	
7	90468-04092-00	CLIP	1	
8	J24-24460-01-00	RELEASE VALVE ASSEMBLY	1	
9	J42-85752-00-00	SENDER UNIT ASS'Y fuel meter	1	
10	J10-24312-00-00	PIPE 2	1	
11	90467-11009-00	CLIP	2	
12	809-24560-01-00	FILTER ASSEMBLY	1	
13	90467-11009-00	CLIP	2	
14	90501-08486-00	SPRING, COMPRESSION	1	
15	J10-24366-00-00	CLAMP, FUEL PIPE 1	2	
16	90445-11288-00	HOSE	1	
17	J10-24313-00-00	PIPE 3	1	
18	90461-04011-00	CLAMP	3	
19	7H3-W0017-00-00	FUEL PUMP DIAPHRAGM KIT	1	OPTIONAL PART
	90267-40054-00	RIVET, BLIND	3	
20	90445-11151-00	HOSE	1	
21	90467-11009-00	CLIP	2	
22	J10-24410-02-00	FUEL PUMP ASSEMBLY	1	
23	7H3-24411-00-00	. DIAPHRAGM	1	
24	7H3-24434-00-00	. GASKET	1	
25	98503-06018-00	SCREW, pan head (92503-06018-00)	2	
26	92995-06100-00	WASHER, SPRING	2	

CONTINUED ON NEXT FRAME ►

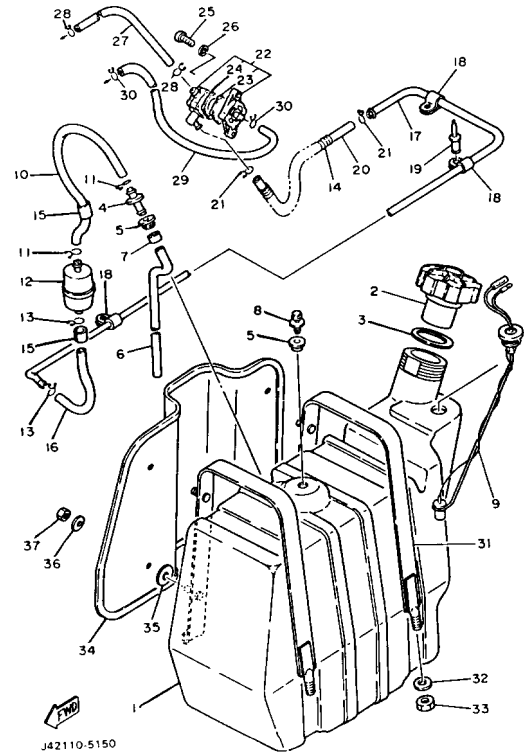

## FUEL TANK

Ref. No.	Part Number	Description	Qty	Remarks
27	90445-09069-00	HOSE .....	1	
28	90467-08017-00	CLIP .....	2	
29	90445-10449-00	HOSE .....	1	
30	90467-09006-00	CLIP .....	2	
31	J17-24173-00-00	BAND, TNK FITTING 1 .....	2	
32	90201-08107-00	WASHER, PLATE .....	2	
33	95611-08100-00	NUT, U .....	2	
34	J17-24129-01-00	COVER, SIDE 1 .....	1	
35	90202-08111-00	WASHER, PLATE .....	4	
36	90201-06067-00	WASHER, PLATE .....	4	
37	7H3-W0017-00-00	FUEL PUMP DIAPHRAGM KIT .	1	OPTIONAL PART
	95601-06100-00	NUT, U .....	4	

# BRAKE

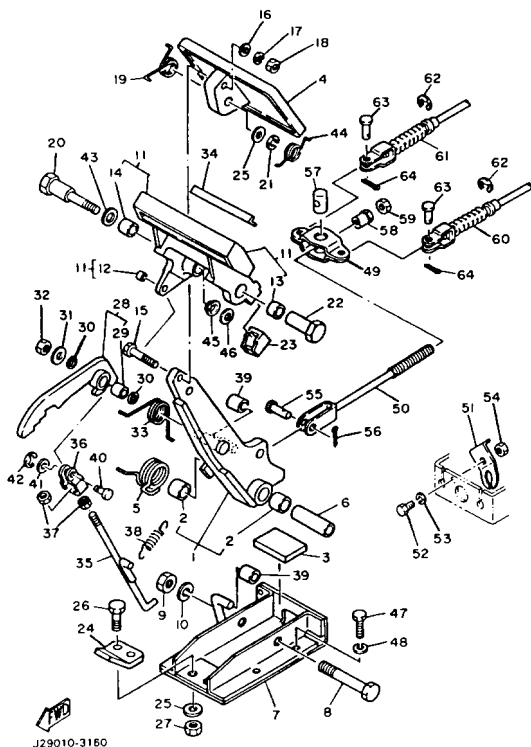

Ref. No.	Part Number	Description	Qty	Remarks
1	92990-10600-00	. WASHER, PLATE .....	1	
	99080-07600-00	. CIRCLIP (E) .....	1	
	99999-01757-00	BRAKE ARM CMLPT (J17-27250-01) .....	1	
	J17-27250-02-00	. BRAKE ARM COMP. ....	1	
2	90384-14080-00	. BUSH, BIMETAL .....	2	
3	J17-27245-00-00	PAD, BRAKE PEDAL .....	1	
4	J10-27211-00-00	PEDAL, BRAKE .....	1	
5	90508-40543-00	SPRING, TORSION .....	1	
6	90387-107F8-00	COLLAR .....	1	
7	J17-25654-00-00	BRACKET, PEDAL .....	1	
8	90101-10447-00	BOLT, HEX. ....	1	
9	95606-10100-00	BOLT, STUD .....	1	
10	92990-10100-00	WASHER, SPRING .....	1	
11	99999-01799-00	PARKING PEDAL COMP. (J17-25670-00) .....	1	
	J17-25670-01-00	. PARKING PEDAL COMP. ....	1	
	J17-25679-01-00	. DAMPER .....	2	
12	90384-05163-00	. BUSH, BIMETAL .....	1	
13	90384-12164-00	. BUSH, BIMETAL .....	1	
14	90380-12051-00	. BUSH, SOLID .....	1	
15	90101-06555-00	BOLT, HEX. ....	1	
16	92990-06200-00	WASHER .....	1	
17	92995-06100-00	WASHER, SPRING .....	1	
18	95380-06600-00	NUT .....	1	
19	90508-23542-00	SPRING, TORSION .....	1	
20	90109-08669-00	BOLT .....	1	
21	92990-08100-00	WASHER .....	1	
22	90179-08378-00	NUT .....	1	

CONTINUED ON NEXT FRAME ►

# BRAKE

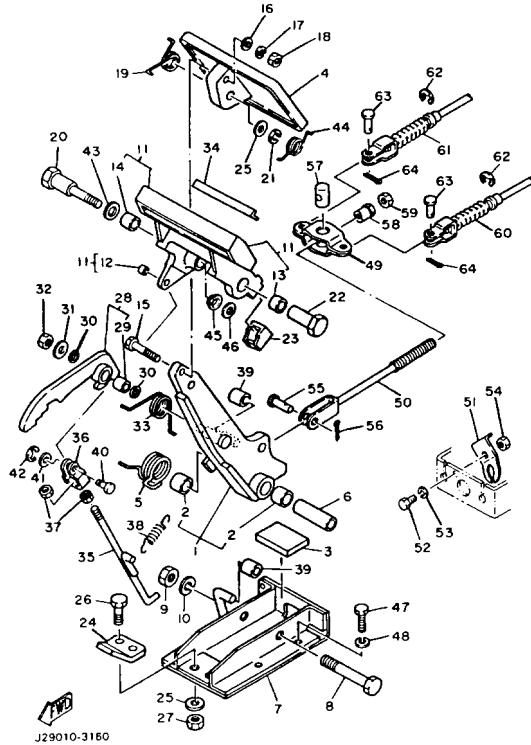

Ref. No.	Part Number	Description	Qty	Remarks
23	J17-25679-01-00	DAMPER .....	1	
24	J17-27246-00-00	NAIL, BRAKE .....	1	
25	92990-08200-00	WASHER, PLAIN .....	1	
26	97001-08025-00	BOLT (1NV) .....	2	
27	95611-08100-00	NUT, U .....	2	
28	J17-W2561-00-00	SECTOR, PARKING BRAKE ..	1	
29	90384-10162-00	. BUSH, BIMETAL .....	1	
30	J17-27221-00-00	SEAL, SHAFT .....	2	
31	90201-065F3-00	WASHER, PLATE .....	1	
32	95601-06100-00	NUT, U .....	1	
33	90508-14548-00	SPRING, TORSION .....	1	
34	J17-25672-00-00	PAD, PARKING PEDAL .....	1	
35	J17-27231-00-00	ROD, BRAKE .....	1	
36	J17-27232-00-00	END, ROD .....	1	
37	95380-06700-00	NUT .....	2	
38	90506-12277-00	SPRING, TENSION .....	1	
39	J17-25673-00-00	DAMPER, BRAKE .....	2	
40	J17-27228-00-00	PIN, LINK JOINT .....	1	
41	92901-05600-00	WASHER, PLATE .....	1	
42	99080-05600-00	CIRCLIP .....	1	
43	90201-123F2-00	WASHER, PLAIN .....	1	
44	90508-26557-00	SPRING, TORSION .....	1	
45	90380-12105-00	BUSH, SOLID .....	1	
46	90201-104G8-00	WASHER, PLAIN .....	2	
47	97011-06016-00	BOLT .....	4	
48	92995-06100-00	WASHER, SPRING .....	4	
49	J10-25681-00-00	EQUALIZER, BRAKE .....	1	
50	J20-25685-00-00	ROD .....	1	
51	J13-25656-00-00	BRKT, STOP LT SWCHSTOP LIGHT SWITCH .....	1	

CONTINUED ON NEXT FRAME ►

# BRAKE

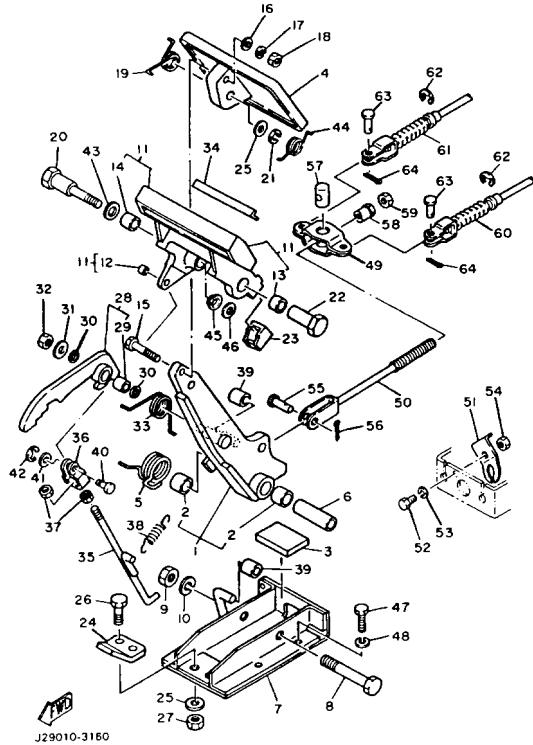

Ref. No.	Part Number	Description	Qty	Remarks
52	97313-06016-00	BOLT, HEXAGON	1	
53	92995-06100-00	WASHER, SPRING	1	
54	95380-06600-00	NUT	1	
55	91701-10022-00	PIN	1	
56	91490-30020-00	PIN, COTTER	1	
57	90249-14129-00	PIN	1	
58	90179-08261-00	NUT	1	
59	95303-08700-00	NUT	1	
60	J56-F6341-00-00	CABLE, BRAKE	1	
61	J56-F6351-00-00	CABLE, BRAKE	1	
62	99001-09600-00	CIRCLIP	4	
63	91701-08018-00	PIN	4	
64	91490-25020-00	PIN, COTTER	4	

# BRAKE 2

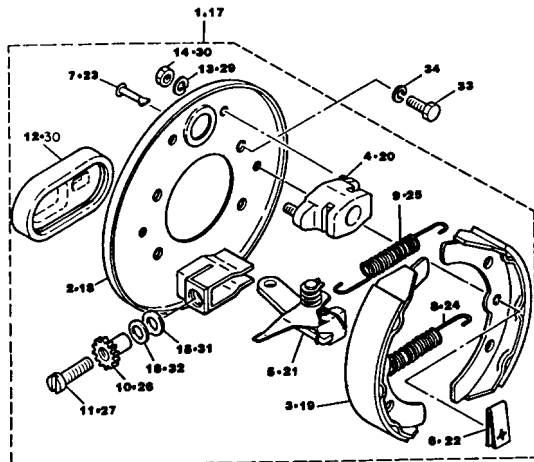

J31100-4170

Ref. No.	Part Number	Description	Qty	Remarks
1	J17-27280-01-00	BACKING PLT ASSEMBLY 1 ..	1	
2	J17-27208-00-00	. BACKING PLATE SUB ASSEMBLY 1 (R.H) .....	1	
3	J55-W2536-00-00	. BRAKE SHOE SET .....	1	
4	J17-27206-00-00	. ANCHOR BODY COMP. ....	1	
5	J17-27204-01-00	. LEVER ASSEMBLY 1 .....	1	
6	J10-27281-00-00	. SPRING, SHOE CLAMP .....	2	
7	J10-27282-00-00	. PIN, SHOE HOLD DOWN ....	2	
8	90506-20281-00	. SPRING, TENSION .....	1	
9	90506-26191-00	. SPRING, TENSION .....	1	
10	J17-27238-00-00	. NUT, ADJUSTING .....	1	
11	90109-08657-00	. BOLT .....	1	
12	J10-27286-00-00	. COVER, DUST .....	1	
13	92995-06100-00	. WASHER, SPRING .....	2	
14	95380-06600-00	. NUT .....	2	
15	90201-121H8-00	. WASHER, PLATE .....	1	
16	90201-121H9-00	. WASHER, PLATE .....	1	
17	J17-27290-01-00	BACKING PLT ASSEMBLY 2 ..	1	
18	J17-27209-00-00	. BACKING PLATE SUB ASSEMBLY 2 (L.H) .....	1	
19	J55-W2536-00-00	. BRAKE SHOE SET .....	1	
20	J17-27206-00-00	. ANCHOR BODY COMP. ....	1	
21	J17-27205-01-00	. LEVER ASSEMBLY 2 .....	1	
22	J10-27281-00-00	. SPRING, SHOE CLAMP .....	2	
23	J10-27282-00-00	. PIN, SHOE HOLD DOWN ....	2	
24	90506-20281-00	. SPRING, TENSION .....	1	
25	90506-26191-00	. SPRING, TENSION .....	1	
26	J17-27258-00-00	. NUT, ADJUSTING .....	1	
27	90109-08659-00	. BOLT .....	1	

CONTINUED ON NEXT FRAME ►

# BRAKE 2

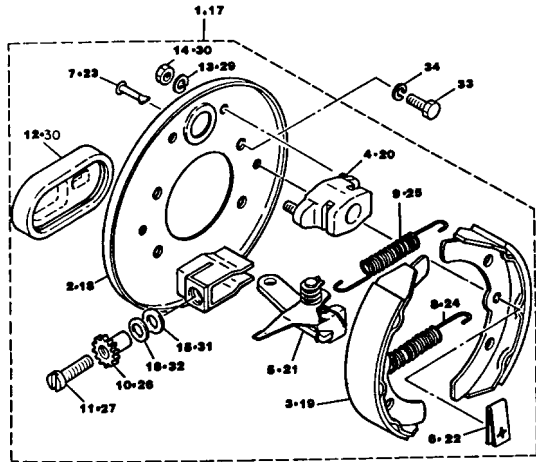

J31100-4170

Ref. No.	Part Number	Description	Qty	Remarks
28	J10-27286-00-00	. COVER, DUST .....	1	
29	92995-06100-00	. WASHER, SPRING .....	2	
30	95380-06600-00	. NUT .....	2	
31	90201-121H8-00	. WASHER, PLATE .....	1	
32	90201-121H9-00	. WASHER, PLATE .....	1	
33	97313-08016-00	BOLT, HEXAGON .....	8	
34	92990-08100-00	WASHER .....	8	

# ACCELERATOR

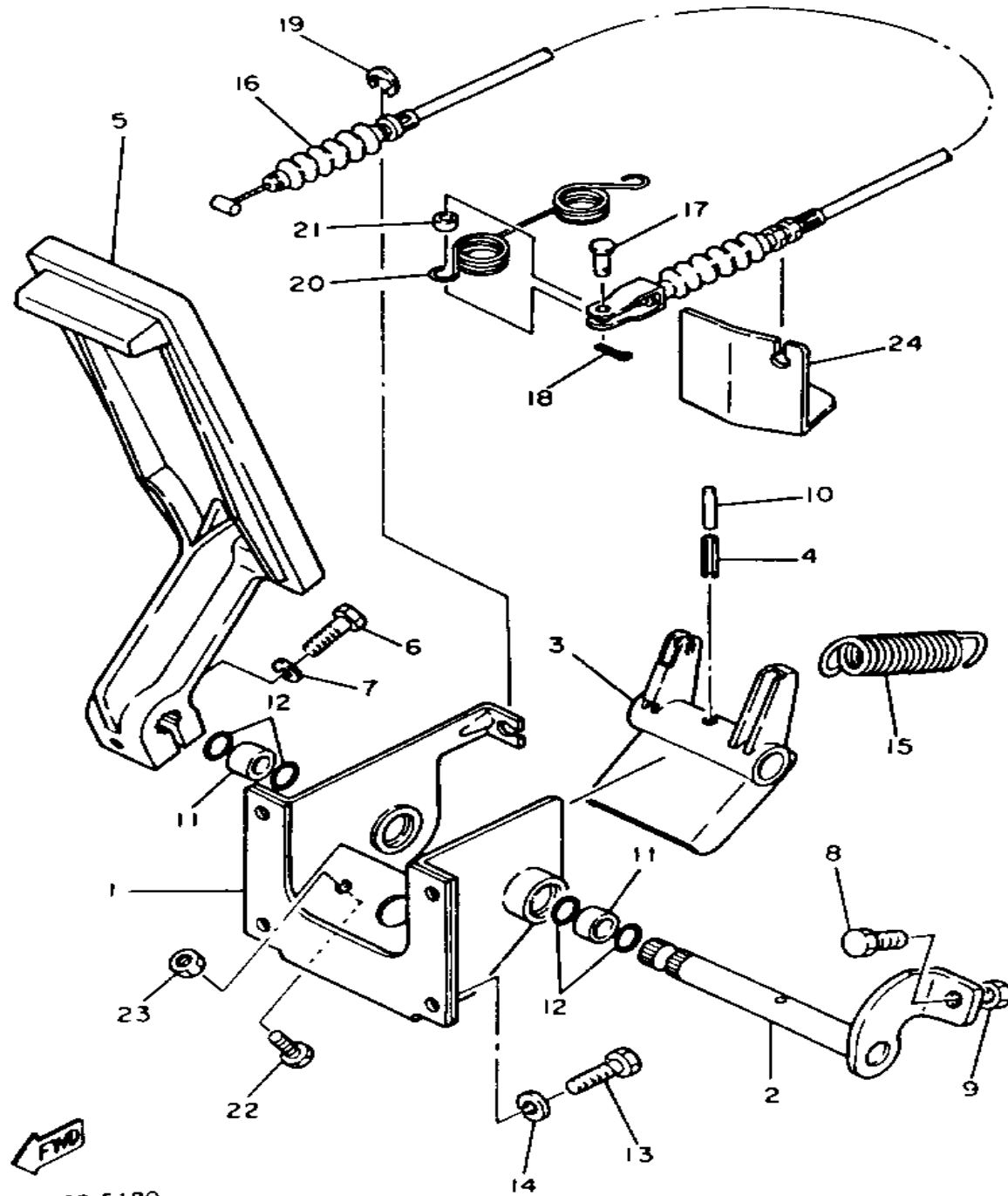

J31100-5180

Ref. No.	Part Number	Description	Qty	Remarks
1	J17-27874-00-00	BRKT, ACCLTR PEDAL .....	1	
2	J17-27853-00-00	SHAFT, PEDAL 1 .....	1	
3	J17-27872-00-00	ARM, ACCLTR PEDAL .....	1	
4	91609-60028-00	PIN, SPRING .....	1	
5	JF3-27871-00-00	PEDAL, ACCELERATOR .....	1	
6	97011-06025-00	BOLT (97001-06025) .....	1	
7	92995-06100-00	WASHER, SPRING .....	1	
8	90106-08040-00	BOLT, RD. HEX .....	1	
9	95303-08700-00	NUT .....	1	
10	91609-35028-00	PIN, SPRING .....	1	
11	90384-14080-00	BUSH, BIMETAL .....	2	
12	93210-14104-00	O-RING .....	4	
13	97301-06014-00	BOLT, HEXAGON .....	4	
14	92995-06100-00	WASHER, SPRING .....	4	
15	90506-26282-00	SPRING, TENSION .....	1	
16	J17-26311-00-00	CABLE, THROTTLE 1 .....	1	
17	91702-05012-00	PIN .....	1	
18	90468-10050-00	CLIP .....	1	
19	99080-07600-00	CIRCLIP (E) .....	1	
20	90508-16460-00	SPRING, TORSION .....	1	
21	90560-05001-00	SPACER .....	1	
22	97011-06025-00	BOLT (97001-06025) .....	1	
23	95380-06700-00	NUT .....	1	
24	J10-27981-00-00	BRACKET, THROTTLE .....	1	

# GOVERNOR

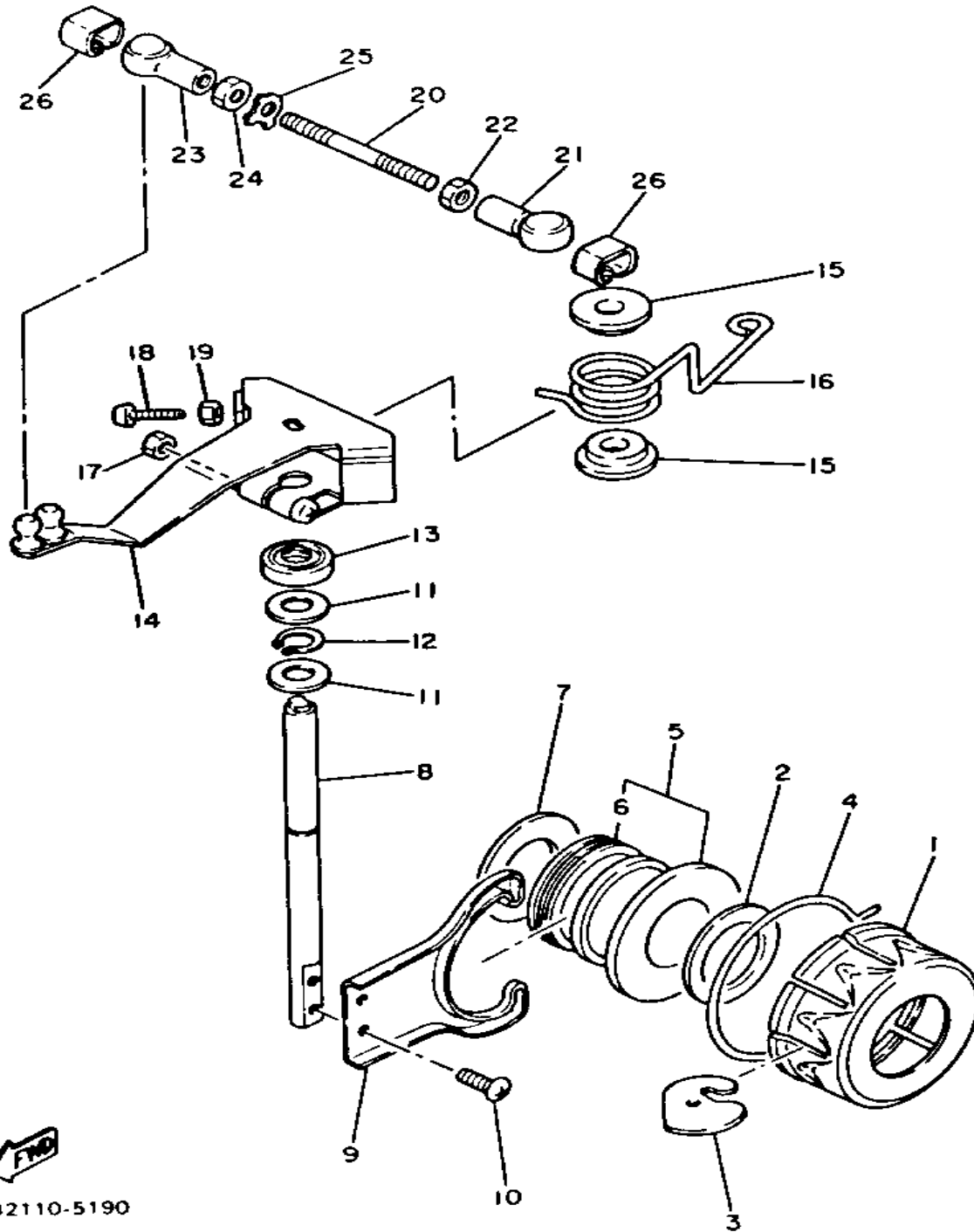

Ref. No.	Part Number	Description	Qty	Remarks
1	J10-27912-00-00	RETAINER	1	
2	90387-21690-00	COLLAR	1	
3	J10-27913-00-00	WEIGHT	12	
4	J10-27911-00-00	HOLDER	1	
5	J10-27927-00-00	LIFTER	1	
6	93342-22502-00	. BEARING, THRUST	1	
7	90201-20275-00	WASHER, PLATE	1	
8	J10-27921-01-00	SHAFT, GOVERNOR	1	
9	J10-27922-00-00	FORK, GOVERNOR	1	
10	98580-04008-00	SCREW, PAN HEAD	2	
11	90202-08110-00	WASHER, PLATE	2	
12	99009-06600-00	CIRCLIP	1	
13	93109-08050-00	OIL SEAL	1	
14	J10-27951-01-00	LEVER, SPEED LMTR	1	
15	90386-08141-00	BUSH	2	
16	90508-40398-00	SPRING, TORSION	1	
17	95380-06600-00	NUT	1	
18	J10-27959-00-00	SCREW, ADJUSTING	1	
19	95301-05700-00	NUT (95302-05700)	1	
20	J10-14836-00-00	ROD	1	
21	J10-14833-01-00	JOINT	1	
22	95301-05700-00	NUT (95302-05700)	1	
23	J10-14864-01-00	JOINT	1	
24	90170-05190-00	NUT, HEXAGON	1	
25	J24-14842-00-00	PLATE, CON ROD	1	
26	90468-05112-00	CLIP	2	



J42110-5190

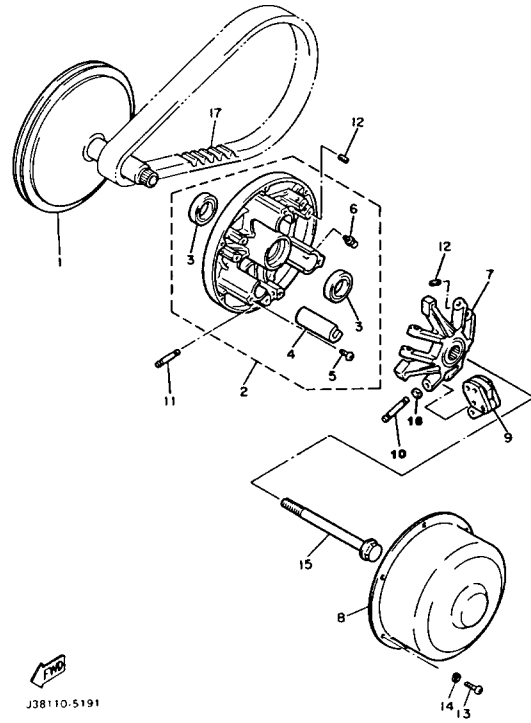

# PRIMARY SHEAVE

Ref. No.	Part Number	Description	Qty	Remarks
1	J42-46210-00-00	PRI FIXED SHEAVESHEAVE COMP .....	1	
2	J38-46220-00-00	PRIMARY SLIDING SHEAVE COMP. ....	1	
3	93102-28348-00	. OIL SEAL .....	2	
4	J38-46253-00-00	. SLIDER .....	3	
5	98901-05008-00	. SCREW, BIND .....	3	
6	93700-06004-00	. NIPPLE, GREASE .....	1	
7	J38-46251-00-00	SPIDER .....	1	
8	J38-46231-00-00	CAP .....	1	
9	90202-07164-00	. WASHER, PLATE .....	2	
	90202-07186-00	. WASHER, PLATE .....	2	
	90387-076U6-00	. COLLAR .....	1	
	99999-01831-00	WEIGHT LINK ASS'Y (J42-46205-00-00) .....	3	
	J42-42605-01-00	. WEIGHT LINK ASS'Y .....	1	
10	J38-46236-00-00	PIN, WEIGHT .....	3	
11	J38-46237-00-00	PIN, WEIGHT 2 .....	3	
12	90113-04050-00	BOLT, SET .....	12	
13	98501-05010-00	SCREW, PAN HEAD .....	6	
14	92990-05100-00	WASHER, SPRING .....	6	
15	J38-46249-00-00	BOLT .....	1	
16	90202-07164-00	WASHER, PLATE .....	6	
17	J17-46241-00-00	BELT .....	1	

J38110-5191

## SECONDARY SHEAVE

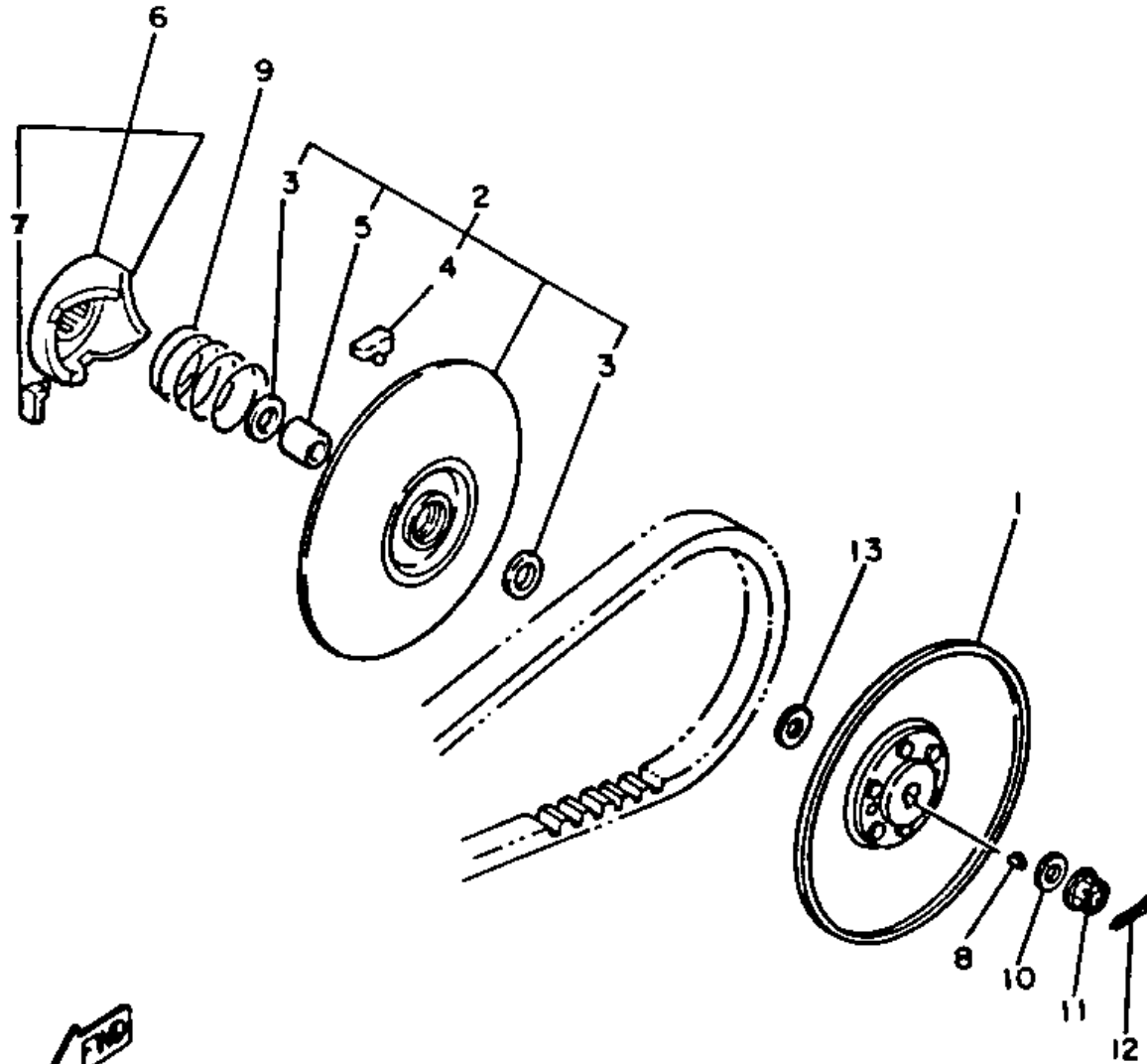

Ref. No.	Part Number	Description	Qty	Remarks
1	J55-G6260-00-00	SECONDARY FIXED SHEAVE COMP. ....	1	
2	J17-46270-01-00	SECONDARY SLIDING SHEAVE COMP. ....	1	
3	93102-20309-00	. SEAL, OIL .....	2	
4	801-17688-10-00	. SHOE, RAMP .....	3	
5	90384-20143-00	. BUSH, BIMETAL FORM FORMED .....	1	
6	J55-G6280-00-00	SEC SPRNG SEAT CMP (J38-46280-00) .....	1	
7	801-17688-10-00	SHOE, RAMP .....	3	
8	90280-05022-00	KEY, WOODRUFF .....	1	
9	90501-45600-00	SPRING, COMPRESSION .....	1	
10	90201-12588-00	WASHER, PLATE .....	1	
11	90171-12023-00	NUT, CASTLE .....	1	
12	91401-30030-00	PIN, COTTER .....	1	
13	90202-20130-00	WASHER, PLAIN .....	1	



J42110-5210

# TRANSMISSION 1

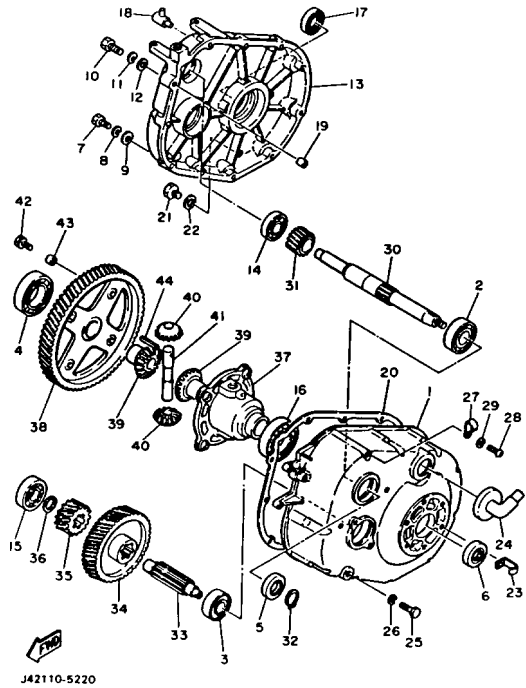

Ref. No.	Part Number	Description	Qty	Remarks
1	J11-46311-00-00	CASE, TRANS 1 .....	1	
2	93306-20541-00	BEARING (B6205) .....	1	
3	93306-20421-00	BEARING .....	1	
4	93306-00803-00	BEARING (B6008) .....	1	
5	93102-25017-00	OIL SEAL .....	1	
6	93102-22189-00	OIL SEAL .....	1	
7	97313-08035-00	BOLT, HEXAGON .....	9	
8	92990-08100-00	WASHER .....	9	
9	92901-08600-00	WASHER .....	9	
10	97313-08045-00	BOLT .....	2	
11	92990-08100-00	WASHER .....	2	
12	92901-08600-00	WASHER .....	2	
13	J10-46312-00-00	CASE, TRANS 2 .....	1	
14	93306-20324-00	BEARING .....	1	
15	93306-20421-00	BEARING .....	1	
16	93306-00803-00	BEARING (B6008) .....	1	
17	93102-22189-00	OIL SEAL .....	1	
18	8E4-24461-00-00	PIPE, JOINT .....	1	
19	99510-12016-00	PIN, DOWEL .....	2	
20	J10-46319-01-00	GASKET .....	1	
21	90340-14036-00	PLUG, STRAIGHT SCRW .....	2	
22	90430-14043-00	GASKET .....	2	
23	90465-06100-00	CLAMP .....	1	
24	835-47559-00-00	CAP 2 .....	1	
25	97011-10020-00	BOLT .....	2	
26	92990-10100-00	WASHER, SPRING .....	2	
27	90465-08028-00	CLAMP .....	1	
28	98580-06010-00	SCREW, PAN HEAD (92503-06010) .....	1	

CONTINUED ON NEXT FRAME ►

# TRANSMISSION 1

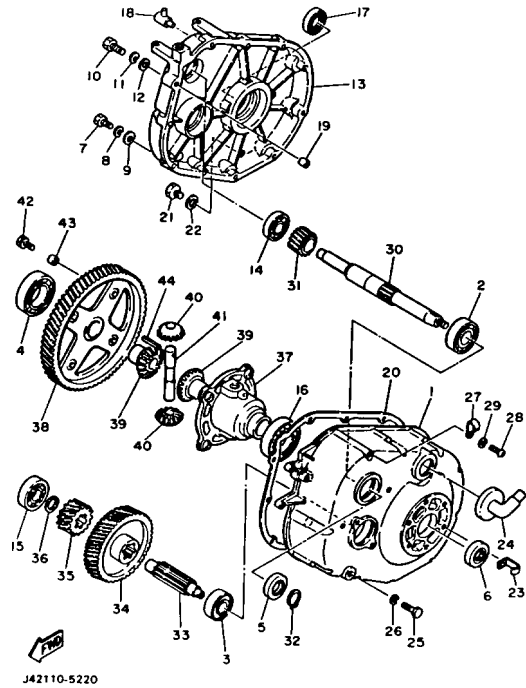

Ref. No.	Part Number	Description	Qty	Remarks
29	92995-06100-00	WASHER, SPRING .....	1	
30	J10-46321-00-00	SHAFT, INPUT .....	1	
31	J10-46331-02-00	GEAR, IMPUT 1 .....	1	
32	93410-25017-00	CIRCLIP .....	1	
33	J10-46351-00-00	SHAFT, COUNTER .....	1	
34	J10-46361-02-00	GEAR, COUNTER 1 .....	1	
35	J17-46362-00-00	GEAR, COUNTER 2 .....	1	
36	90201-20272-00	WASHER, PLATE .....	1	
37	J38-46411-01-00	CASE, DIFFERENTIAL .....	1	
38	J41-46421-00-00	GEAR, RING .....	1	
39	J38-46414-00-00	GEAR, DIFFERENTIAL SIDE ..	2	
40	J38-46415-00-00	PINION, DIFFERENTIAL .....	2	
41	J38-46417-02-00	PIN, DIFFERENTIAL .....	1	
42	90105-08390-00	BOLT, WASHER BASED .....	4	
43	91812-16001-00	PIN, DOWEL .....	2	
44	91609-40040-00	PIN, SPRING .....	1	

# REAR AXLE - WHEEL

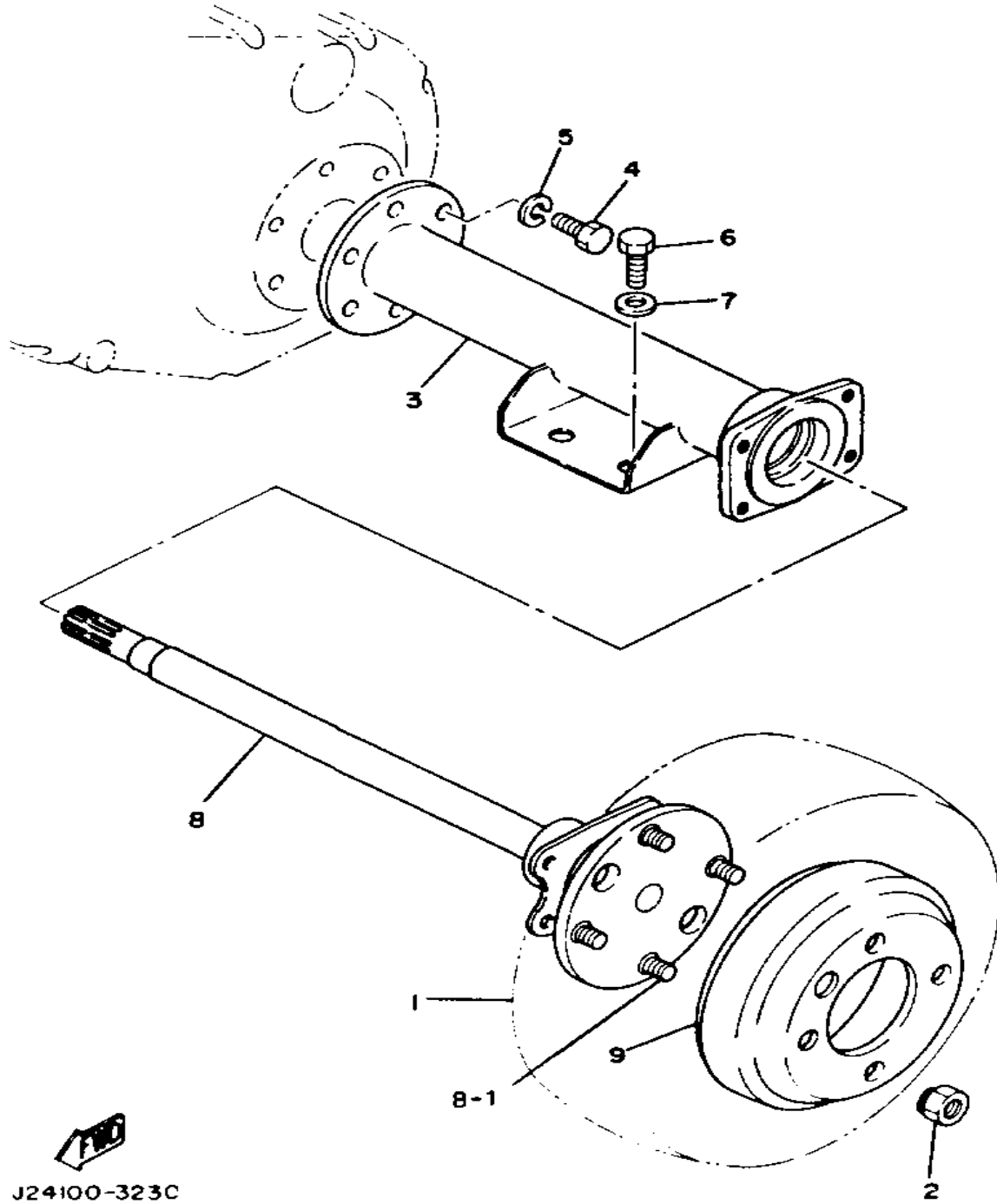

Ref. No.	Part Number	Description	Qty	Remarks
1	*---	FRONT WHEEL ASSEMBLY	2	LM (See Note)
2	90179-12262-00	NUT	8	
3	J10-46540-00-00	R.AXLE HOUSING 1COMP	2	
4	97013-08025-00	BOLT	12	
5	92990-08100-00	WASHER	12	
6	97011-10020-00	BOLT	8	
7	92990-10100-00	WASHER, SPRING	8	
8	J17-46510-01-00	REAR AXLE SHAFT 1	2	
9	J55-G6521-00-00	DRUM	2	
8-1	90114-12004-00	. BOLT, RIBBED NECK	8	

J24100-323C

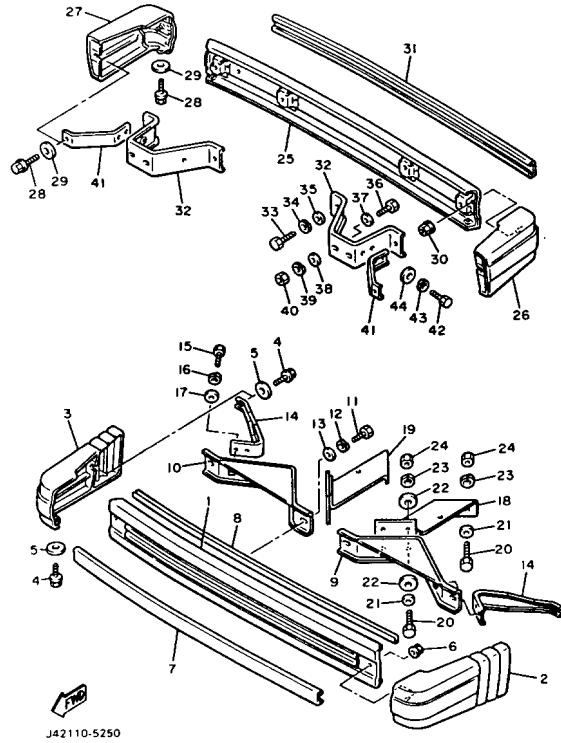

# BUMPER

Ref. No.	Part Number	Description	Qty	Remarks
1	J42-78106-00-00	BUMPER SUB-ASS'Y, front ..	1	
2	J42-77505-00-00	BUMPER RUBBER COMP. 1 ..	1	
3	J42-77506-00-00	BUMPER RUBBER COMP. 2 ..	1	
4	95816-06016-00	BOLT, FLANGE .....	4	
5	90201-060A3-00	WASHER, PLATE .....	4	
6	95701-06500-00	NUT, FLANGE .....	2	
7	J42-78162-00-00	PAD, front bumper .....	1	
8	J42-77588-00-00	DAMPER .....	1	
9	J42-78164-00-00	STAY, FRT BUMPER 1 (J17-78165-00) .....	1	
10	J42-78165-00-00	STAY, FRT BUMPER 2 (J17-78165-00) .....	1	
11	97022-08016-00	BOLT .....	4	
12	92990-08100-00	WASHER .....	4	
13	92990-08600-00	WASHER, PLATE .....	4	
14	J42-77535-00-00	STAY 1 .....	2	
15	97313-06016-00	BOLT, HEXAGON .....	4	
16	92995-06100-00	WASHER, SPRING .....	4	
17	90201-065F3-00	WASHER, PLATE .....	4	
18	J42-78176-00-00	STAY, front bumper 3 .....	1	
19	J42-78177-00-00	STAY, front bumper 4 .....	1	
20	97013-08025-00	BOLT .....	8	
21	92990-08600-00	WASHER, PLATE .....	8	
22	90201-085E6-00	WASHER PLATE .....	8	
23	92990-08100-00	WASHER .....	8	
24	95333-08600-00	NUT .....	8	
25	J42-78107-00-00	BUMPER SUB-ASS'Y, rear ...	1	
26	J42-77507-00-00	BUMPER RUBBER COMP. 3 ..	1	
27	J42-77508-00-00	BUMPER RUBBER COMP. 4 ..	1	

CONTINUED ON NEXT FRAME ►

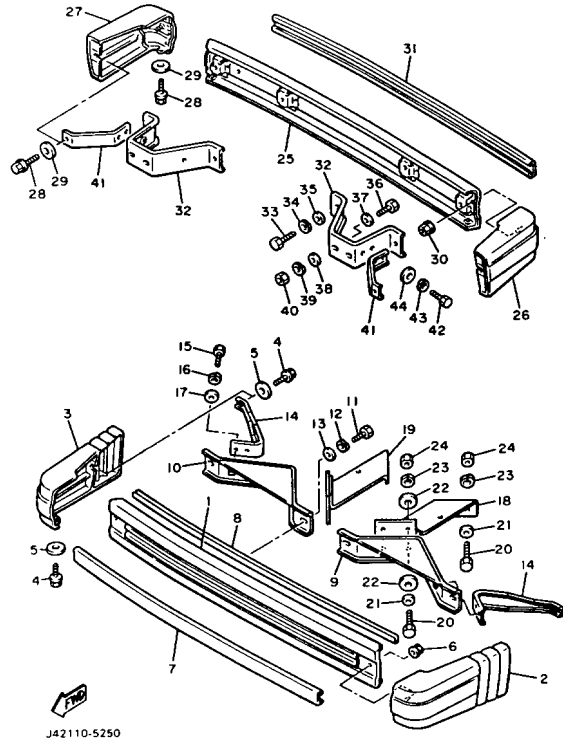

# BUMPER

Ref. No.	Part Number	Description	Qty	Remarks
28	95816-06016-00	BOLT, FLANGE .....	4	
29	90201-060A3-00	WASHER, PLATE .....	4	
30	95701-06500-00	NUT, FLANGE .....	2	
31	J42-78162-00-00	PAD, front bumper .....	1	
32	J42-78174-00-00	STAY, REAR BUMPER (J10-78174-01) .....	2	
33	97022-08016-00	BOLT .....	4	
34	92990-08100-00	WASHER .....	4	
35	92990-08600-00	WASHER, PLATE .....	4	
36	97013-08025-00	BOLT .....	4	
37	92990-08600-00	WASHER, PLATE .....	4	
38	90201-085E6-00	WASHER PLATE .....	4	
39	92990-08100-00	WASHER .....	4	
40	95303-08600-00	NUT .....	4	
41	J42-77536-00-00	STAY 2 .....	2	
42	97313-06016-00	BOLT, HEXAGON .....	4	
43	92995-06100-00	WASHER, SPRING .....	4	
44	90201-065F3-00	WASHER, PLATE .....	4	

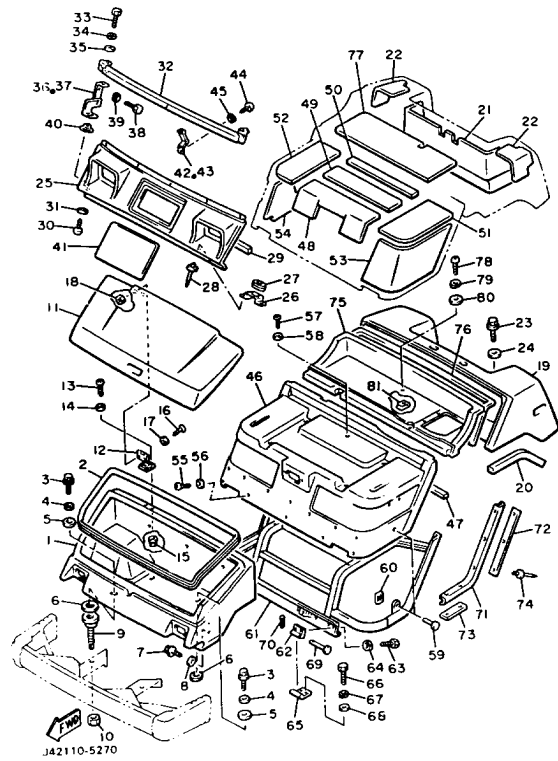

## BODY

Ref. No.	Part Number	Description	Qty	Remarks
1	J42-7810A-00-00	FRONT COMP .....	1	
2	J42-7815G-00-00	SEAL, front storage .....	1	
3	95811-08030-00	BOLT, FLANGE .....	4	
4	90201-084K7-00	WASHER, PLATE .....	4	
5	90202-09167-00	WASHER, plate .....	6	
6	90202-09169-00	WASHER, plate .....	4	
7	90119-06063-00	BOLT, WITH WASHER .....	4	
8	90201-06074-00	WASHER, PLATE .....	4	
9	J42-77519-00-00	BOLT .....	2	
10	95301-14700-00	NUT .....	2	
11	J42-7810E-01-00	FRONT STORAGE LID COMP (J42-7810E-00) .....	1	
12	J42-78153-00-00	HINGE, front lid .....	2	
13	98511-04025-00	SCREW, PAN HEAD .....	8	
14	92990-04200-00	WASHER, PLAIN .....	8	
15	95701-04300-00	NUT, flange .....	8	
16	98701-05016-00	SCREW, FLAT HEAD .....	4	
17	92990-05200-00	WASHER, PLAIN .....	4	
18	95701-05300-00	NUT, NYLON .....	4	
19	J42-7810H-01-00	REAR BODY COMP (J42-7810H-00) .....	1	
20	J42-7814E-00-00	SEAL, body side 1 .....	2	
21	J42-7825A-01-00	PAD, silencer 0 .....	1	
22	J42-7825E-01-00	PAD, silencer 1 .....	2	
23	95821-08020-00	BOLT, FLANGE (95801-08020) .	4	
24	90201-084K7-00	WASHER, PLATE .....	4	
25	J42-7811J-00-00	BASE, headlight .....	1	
26	J42-77723-01-00	BRACKET 3 .....	2	
27	90480-22084-00	GROMMET .....	2	

CONTINUED ON NEXT FRAME ►

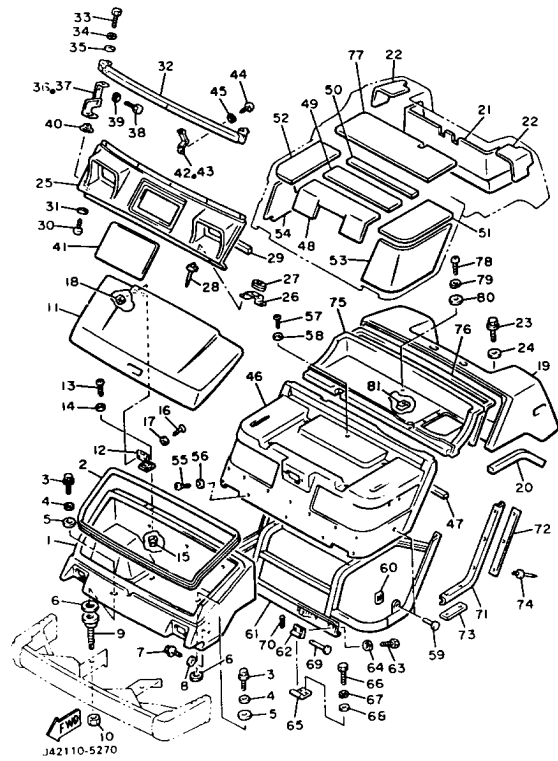

## BODY

Ref. No.	Part Number	Description	Qty	Remarks
28	90267-40075-00	RIVET, BLIND	4	
29	J42-78247-01-00	SEAL 3	1	
30	97706-50125-00	SCREW, tapping	2	
31	90201-05033-00	WASHER, PLATE	2	
32	J42-78122-01-00	REINFORCEMENT 2	1	
33	97313-06016-00	BOLT, HEXAGON	2	
34	92995-06100-00	WASHER, SPRING	2	
35	90201-06074-00	WASHER, PLATE	2	
36	J42-77721-01-00	BRACKET 1	1	
37	J42-77722-01-00	BRACKET 2	1	
38	97313-08020-00	BOLT, HEXAGON	4	
39	92990-08100-00	WASHER	4	
40	90480-07241-00	GROMMET	2	
41	J42-7813H-00-00	COVER, ventilator	1	
42	J4-27813-M0-00	HINGE, ventilator (L.H)	1	
43	(J42-7813N-00-00)	HINGE, VENTILATO 2	1	
44	97780-50612-00	SCREW, TAPPING	4	
45	92990-05100-00	WASHER, SPRING	4	
46	J42-78141-00-00	PANEL, intermediate body	1	
47	J42-7814A-01-00	SEAL, body upper	1	
48	J42-78251-00-00	PAD, silencer 1	1	
49	J42-78252-00-00	PAD, silencer 2	1	
50	J42-78253-00-00	PAD, silencer 3	1	
51	J42-78254-00-00	PAD, silencer 4	1	
52	J42-78255-00-00	PAD, silencer 5	1	
53	J42-78256-00-00	PAD, silencer 6	1	
54	J42-78257-00-00	PAD, silencer 7	1	
55	98980-06025-00	SCREW, BIND	2	
56	90201-06697-00	WASHER, PLATE	2	

CONTINUED ON NEXT FRAME ►

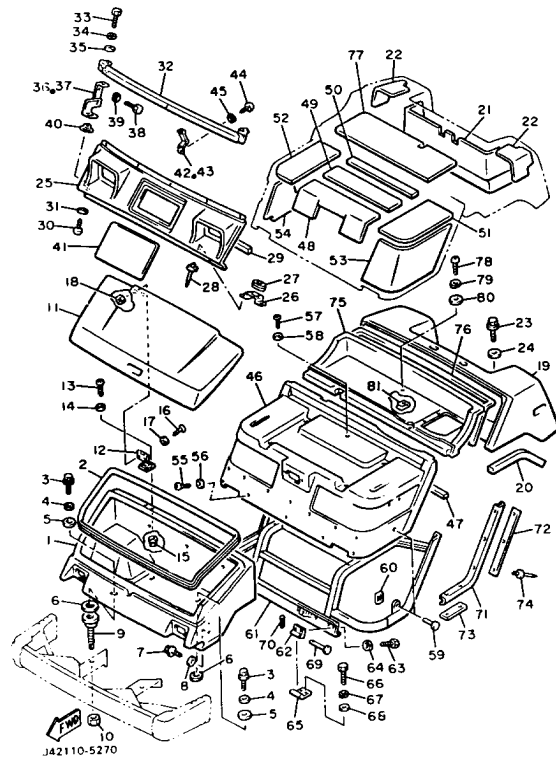

## BODY

Ref. No.	Part Number	Description	Qty	Remarks
57	97780-50612-00	SCREW, TAPPING	1	
58	90201-05556-00	WASHER, PLATE	1	
59	90338-06184-00	PLUG	2	
60	90183-06011-00	NUT, SPRING	2	
61	J42-78121-00-00	REINFORCEMENT 1	1	
	J42-78121-01-00	REINFORCEMENT 1 0 1	1	122~
62	J55-K8143-00-00	HINGE, INTERMEDIATE BODY 1	2	
63	97003-06012-00	BOLT (97001-06012)	4	
64	92990-06100-00	WASHER, SPRING	4	
65	J55-K8144-00-00	HINGE, INTERMEDIATE BODY 2	2	
66	97011-06025-00	BOLT (97001-06025)	4	
67	92995-06100-00	WASHER, SPRING	4	
68	92990-06600-00	WASHER, PLATE	4	
69	91790-06125-00	PIN, CLEVIS	2	
70	91490-20015-00	PIN, COTTER	2	
71	J42-7814V-01-00	SEAL, body side 6	2	
72	J42-7815A-00-00	PLATE, seal support 1	2	
73	J42-7815E-00-00	PLATE, seal support 2	2	
74	90267-32108-00	RIVET, blind	10	
75	J42-7810L-01-00	INSPECTION, lid	1	
76	J42-78159-00-00	SEAL, inspection lid	1	
77	J42-78259-00-00	PAD, silencer 9	1	
78	98580-06016-00	SCREW, PAN HEAD	3	
79	92995-06100-00	WASHER, SPRING	3	
80	90201-06697-00	WASHER, PLATE	3	
81	90183-06028-00	NUT, SPRING	1	

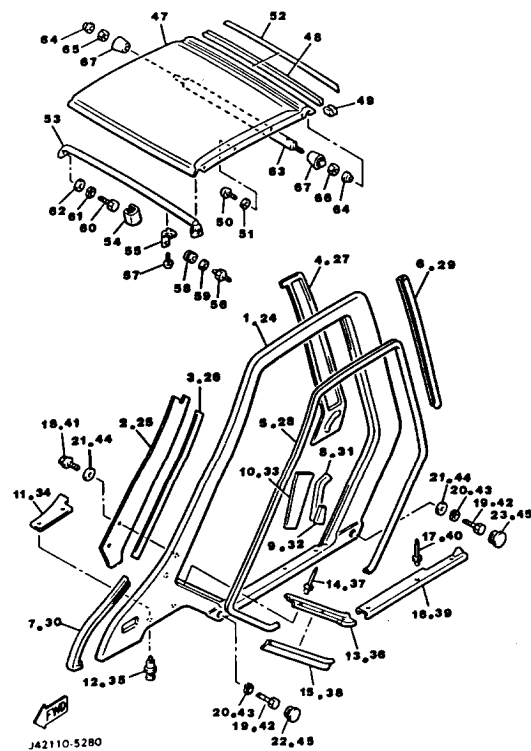

## BODY 2

Ref. No.	Part Number	Description	Qty	Remarks
1	J42-7810F-00-00	SIDE PANEL COMP. (L.H)	1	
2	J42-7817A-00-00	COVER, front pillar (L.H)	1	
3	J42-7717F-00-00	TAPE 2	1	
4	J42-7817F-00-00	COVER, rear pillar (L.H)	1	
5	J42-7817H-00-00	TRIM, side panel 1	1	
6	J42-7817J-00-00	TRIM, side panel 2	1	
7	J42-7817K-00-00	TRIM, side panel 3	1	
8	J42-7814F-00-00	SEAL, body side 2	1	
9	J42-7814R-00-00	SEAL, body side (L.H)	1	
10	J42-7825J-00-00	PAD, silencer 5	1	
11	J42-7818J-00-00	FLAP, side panel	1	
12	90269-07048-00	RIVET	2	
13	J42-7811L-00-00	TRIM, cowl side (L.H)	1	
14	90267-48051-00	RIVET, BLIND	3	
15	J42-7814T-01-00	SEAL, body side 4	1	
16	J42-78249-01-00	TRIM, floor	1	
17	90267-48051-00	RIVET, BLIND	3	
18	95821-08020-00	BOLT, FLANGE (95801-08020)	4	
19	97313-08020-00	BOLT, HEXAGON	2	
20	92990-08100-00	WASHER	2	
21	90201-084K3-00	WASHER, PLATE	5	
22	90338-24177-00	PLUG	1	
23	90338-40178-00	PLUG	1	
24	J42-7810G-00-00	SIDE PANEL COMP. (R.H)	1	
25	J42-7817E-00-00	COVER, front pillar (R.H)	1	
26	J42-7717F-00-00	TAPE 2	1	
27	J42-7817G-00-00	COVER, rear pillar (R.H)	1	
28	J42-7817H-00-00	TRIM, side panel 1	1	
29	J42-7817J-00-00	TRIM, side panel 2	1	

CONTINUED ON NEXT FRAME ►

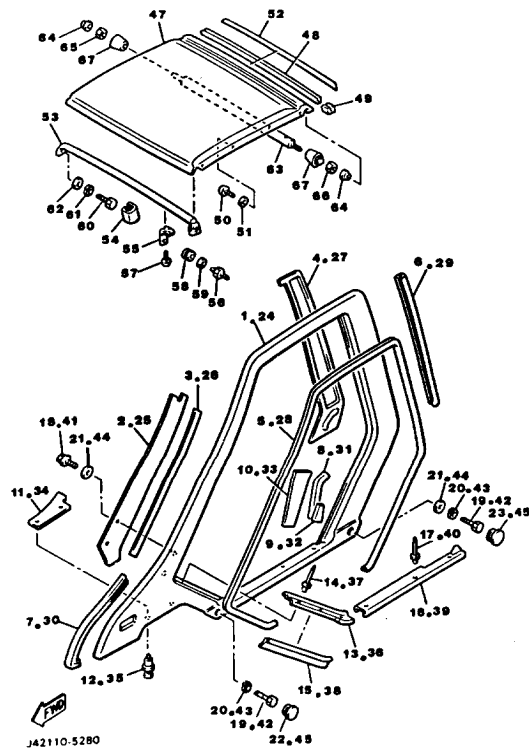

## BODY 2

Ref. No.	Part Number	Description	Qty	Remarks
30	J42-7817K-00-00	TRIM, side panel 3	1	
31	J42-7814F-00-00	SEAL, body side 2	1	
32	J42-7814R-00-00	SEAL, body side (L.H)	1	
33	J42-7825J-00-00	PAD, silencer 5	1	
34	J42-7818J-00-00	FLAP, side panel	1	
35	90269-07048-00	RIVET	2	
36	J42-7811M-00-00	TRIM, cowl side (R.H)	1	
37	90267-48051-00	RIVET, BLIND	3	
38	J42-7814T-01-00	SEAL, body side 4	1	
39	J42-7824A-01-00	TRIM, floor 2	1	
40	90267-48051-00	RIVET, BLIND	3	
41	95821-08020-00	BOLT, FLANGE (95801-08020)	4	
42	97313-08020-00	BOLT, HEXAGON	2	
43	92990-08100-00	WASHER	2	
44	90201-084K3-00	WASHER, PLATE	5	
45	90338-24177-00	PLUG	1	
46	90338-40178-00	PLUG	1	
47	J42-78314-00-00	COVER, sun roof	1	
48	J42-78315-00-00	TRIM, roof	1	
49	J42-7831K-00-00	END, roof trim	2	
50	97780-50320-00	SCREW, tapping	8	
51	90209-05275-00	WASHER	8	
52	J42-7832A-00-00	REFLECTOR, sun-roof	1	
53	J42-78312-01-00	SUPPORT, sun roof 1	1	
54	J42-78349-02-00	CAP, support roof	2	
55	J42-78381-00-00	BRACKET, mirror	2	
56	J42-78382-00-00	JOINT, screw	2	
57	97706-40510-00	SCREW, TAPPING	6	
58	90480-14229-00	GROMMET	2	

CONTINUED ON NEXT FRAME ►

## BODY 2

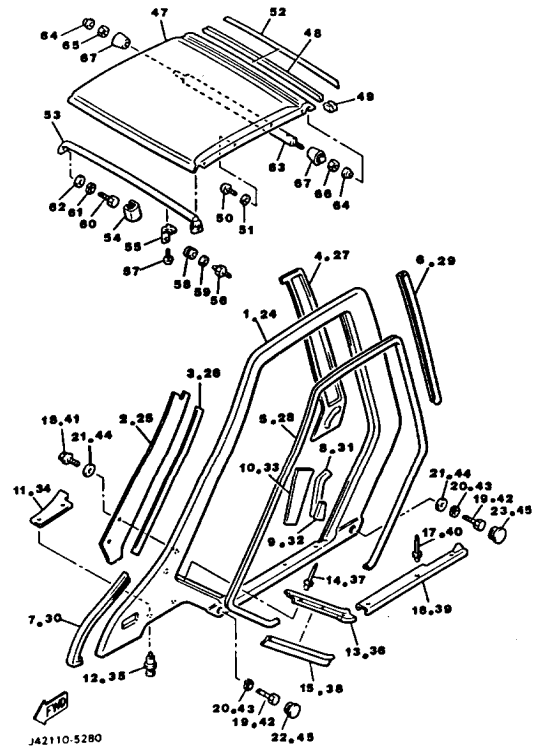

Ref. No.	Part Number	Description	Qty	Remarks
59	90209-10229-00	WASHER .....	2	
60	97013-08025-00	BOLT .....	2	
61	92990-08100-00	WASHER .....	2	
62	90201-08730-00	WASHER, PLATE .....	2	
63	J42-78313-00-00	SUPPORT, sun roof 2 .....	1	
64	(90560-10023-00)	SPACER .....	2	
65	95303-10600-00	NUT (95301-10600) .....	1	
66	90170-10186-00	NUT .....	1	
67	J42-7832F-01-00	GROMMET, roof support 1 ...	2	

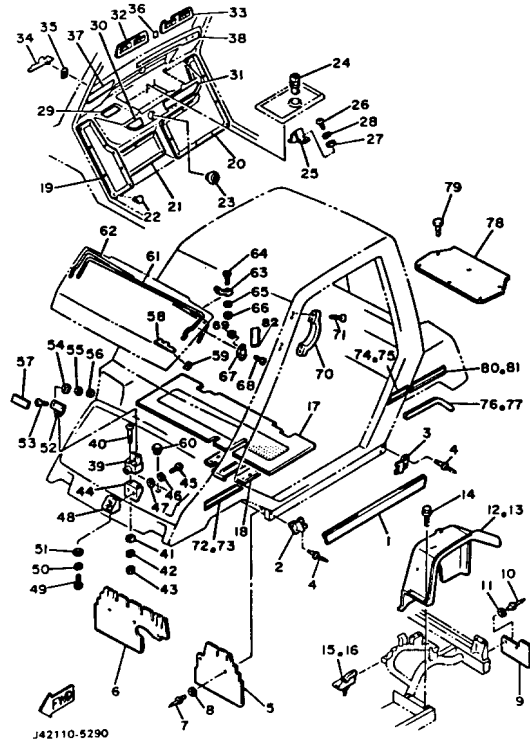

## BODY FITTING

Ref. No.	Part Number	Description	Qty	Remarks
1	J42-7818A-00-00	PROTECTOR, side plate	2	
2	J42-78183-00-00	PLATE, side sill (L.H)	2	
3	J42-78184-00-00	PLATE, side sill (R.H)	2	
4	90267-48116-00	RIVET, blind	8	
5	J42-78187-00-00	FLAP, front fender	1	
6	J42-78189-00-00	FLAP, front fender (R.H)	1	
7	90267-40075-00	RIVET, BLIND	5	
8	90201-05034-00	WASHER, PLATE	5	
9	J42-78199-00-00	FLAP, rear 2	2	
10	90267-40075-00	RIVET, BLIND	4	
11	90201-05034-00	WASHER, PLATE	4	
12	J24-78191-00-00	PANEL, RR FENDER 1	1	
13	J24-78192-00-00	PANEL, RR FENDER 2	1	
14	90119-06029-00	BOLT, WITH WASHER	8	
15	J42-78221-01-00	SHEET, body mounting 1	1	
16	J42-78222-01-00	SHEET, body mounting 2	1	
17	J42-78231-02-00	MAT, main floor 1 (J42-78231-01-00)	1	
18	J42-78271-00-00	SERVICE LID, pedal	1	
19	J42-78232-00-00	MAT, main floor 2	1	
20	J42-78233-01-00	MAT, main floor 3	1	
21	J42-78236-01-00	MAT, pedal floor	1	
	J42-78236-01-00	MAT, pedal floor	1	J42-002819 ~
22	90267-63047-00	RIVET, BLIND	26	
23	J42-77740-01-00	GROMMET, instrument panel	1	
24	25G-21708-00-00	SIDE COVER LOCK ASS'Y (J42-21708-00)	1	
25	J42-78319-00-00	HOOK, end 2	1	
26	97780-50612-00	SCREW, TAPPING	2	

CONTINUED ON NEXT FRAME ►

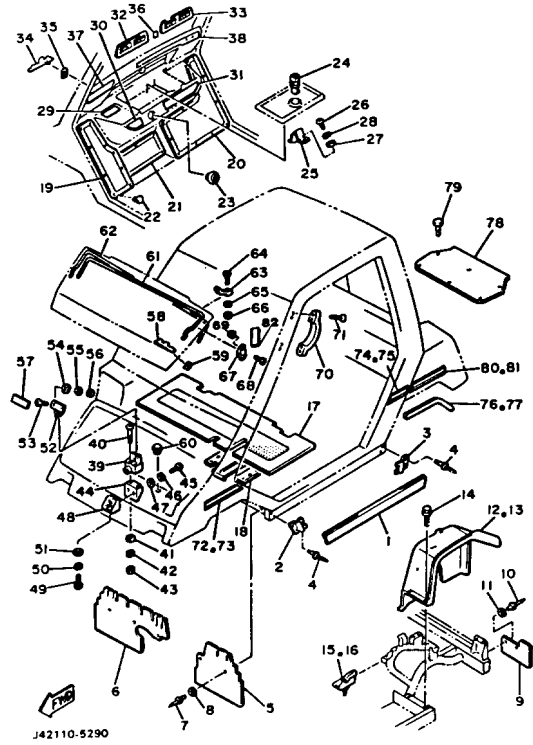

## BODY FITTING

Ref. No.	Part Number	Description	Qty	Remarks
27	92901-05600-00	WASHER, PLATE .....	2	
28	92990-05100-00	WASHER, SPRING .....	2	
29	J55-77768-10-00	LABEL, WARNING (J38-77768-10) .....	1	
30	J42-77717-00-00	ORNAMENT, instrument panel 3 .....	1	
31	J42-77718-00-00	ORNAMENT, instrument panel 4 .....	1	
32	J42-2837X-00-00	GRILL, air outlet 3 .....	1	
33	J42-2837Y-00-00	GRILL, air outlet 4 .....	1	
34	J42-78292-00-00	EMBLEM 2 .....	1	
35	90183-03038-00	NUT, spring .....	2	
36	(J42-77743-00-00)	INDICATOR 3 .....	1	
37	J42-77715-00-00	ORNAMENT instrument panel 1	1	
38	J42-77716-00-00	ORNAMENT, instrument panel 2 .....	1	
39	23T-24705-00-00	SEAT LOCK ASS'Y (J42-24705-00) .....	1	
40	98580-06040-00	SCREW, pan head (92501-06040-00) .....	2	
41	92990-06200-00	WASHER .....	2	
42	92995-06100-00	WASHER, SPRING .....	2	
43	95380-06600-00	NUT .....	2	
44	J42-78323-00-00	BRACKET 1 .....	1	
45	98580-06012-00	SCREW, PAN HEAD .....	2	
46	92995-06100-00	WASHER, SPRING .....	2	
47	92990-06600-00	WASHER, PLATE .....	2	
48	J42-78324-00-00	BRACKET 2 .....	1	
49	98580-06030-00	SCREW PAN HEAD .....	3	
50	92995-06100-00	WASHER, SPRING .....	3	
51	92990-06200-00	WASHER .....	3	

CONTINUED ON NEXT FRAME ►

# BODY FITTING

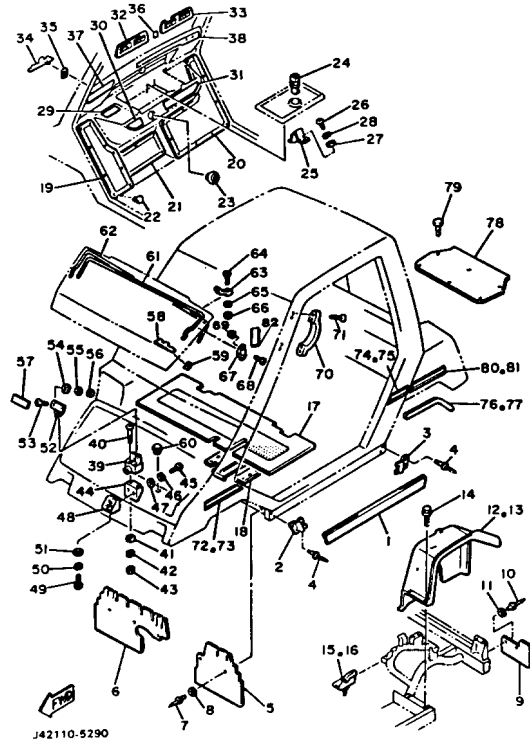

Ref. No.	Part Number	Description	Qty	Remarks
52	J42-78318-00-00	HOOK, end 1	1	
53	98701-05016-00	SCREW, FLAT HEAD	2	
54	92990-05200-00	WASHER, PLAIN	2	
55	92990-05100-00	WASHER, SPRING	2	
56	95301-05600-00	NUT	2	
57	25G-21578-00-00	EMBLEM	1	
58	J42-78292-00-00	EMBLEM 2	1	
59	90183-03038-00	NUT, spring	2	
60	90338-24112-00	PLUG, SPEC'L SHAPE	1	
61	J42-78278-00-00	SPRING, front lid 1	1	
62	J42-78279-00-00	SPRING, front lid 2	1	
63	J42-7827A-00-00	GUIDE 1	2	
64	98501-03016-00	SCREW, PAN HEAD	4	
65	92990-03200-00	WASHER, PLAIN	4	
66	95380-03600-00	NUT	4	
67	J42-7827E-00-00	GUIDE 2	2	
68	98501-03016-00	SCREW, PAN HEAD	4	
69	95380-03600-00	NUT	4	
70	J42-78214-00-00	GRIP, hand	2	
71	97706-50640-00	SCREW, tapping (97706-50140-00)	8	
72	J42-77281-00-00	STRIPE (L.H)	1	
73	J42-77282-00-00	STRIPE (R.H)	91	
74	J42-77283-00-00	STRIPE (L.H)	1	
75	J42-77284-00-00	STRIPE (R.H)	1	
76	J42-7824E-00-00	TRIM, rear body (L.H)	1	
77	J42-7824F-00-00	TRIM, rear body (R.H)	1	
78	J42-78241-00-00	MAT, rear floor	1	
79	90269-06028-00	RIVET	6	

CONTINUED ON NEXT FRAME ►

# BODY FITTING

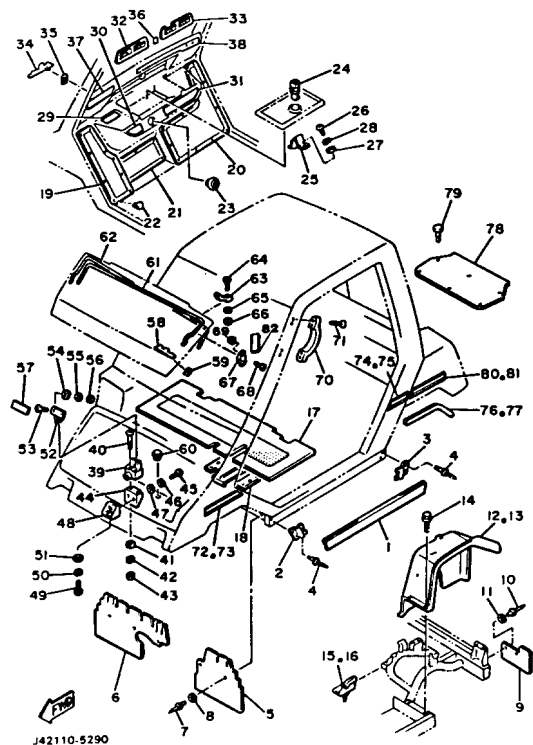

Ref. No.	Part Number	Description	Qty	Remarks
80	J42-77285-00-00	STRIPE (L.H) .....	1	
81	J42-77286-00-00	STRIPE (R.H) .....	1	
82	J42-7824H-00-00	TAPE 1 .....	2	

# INSTRUMENT PANEL

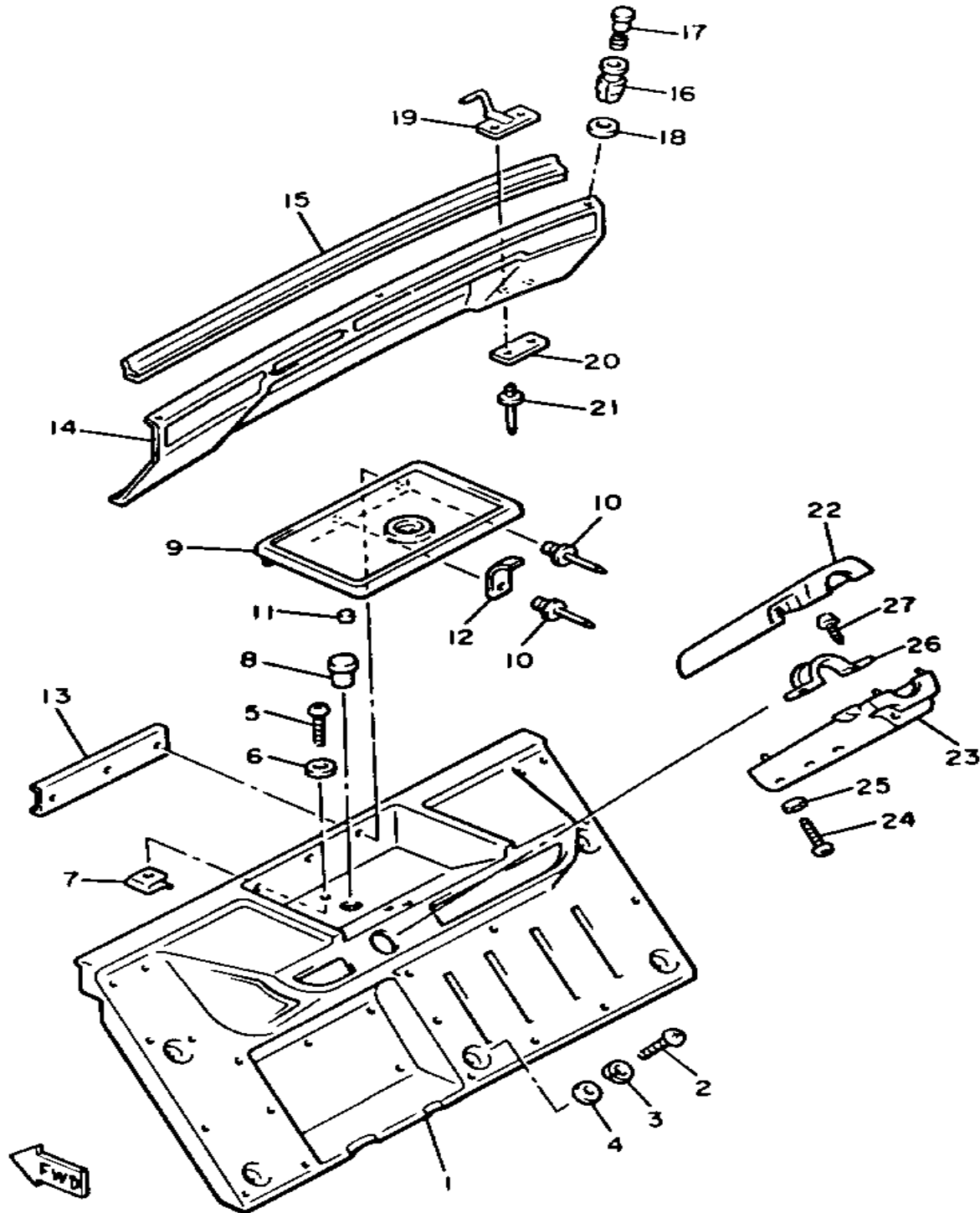

Ref. No.	Part Number	Description	Qty	Remarks
1	J42-77711-01-00	PANEL, instrument	1	
	J42-77711-01-00	PANEL, instrument	1	J42-002819~
2	98503-06014-00	SCREW, PAN HEAD (92502-06016)	5	
3	92995-06100-00	WASHER, SPRING	5	
4	90201-066F3-00	WASHER, plate	5	
5	98980-06016-00	SCREW, BINDING	1	
6	90201-06697-00	WASHER, PLATE	1	
7	90183-06028-00	NUT, SPRING	1	
8	90338-24112-00	PLUG, SPEC'L SHAPE	1	
9	J42-77736-00-00	LID, glove box	1	
10	90267-48086-00	RIVET, BLIND	3	
11	ϕJ4-27773-90-00	DAMPER, lid	2	
12	J42-78288-00-00	SPRING, lid	1	
13	ϕJ4-27812-E0-00	SUPPORT, upper cowl (L.H)	1	
14	J42-77251-01-00	COVER, headlight	1	
15	J42-78248-00-00	SEAL 4	1	
16	4X7-24742-00-00	GROMMET (J42-24742-00-00)	3	
17	5K7-28188-00-00	PLUNGER (J42-28188-00-00)	3	
18	90202-07127-00	WASHER, plate	3	
19	J42-77724-00-00	BRACKET 4	2	
20	J42-77728-00-00	WASHER	2	
21	90267-40075-00	RIVET, BLIND	4	
22	J50-K7732-00-00	COVER, STEER SHFT 1	1	
23	J50-K7733-00-00	COVER, STEER SHFT 2	1	
24	97702-50120-00	SCREW, tapping	4	
25	92901-05600-00	WASHER, PLATE	4	
26	(J42-77734-00-00)	BRACKET, STEER.COV.	2	
27	97702-50120-00	SCREW, tapping	4	

# WINDSHIELD

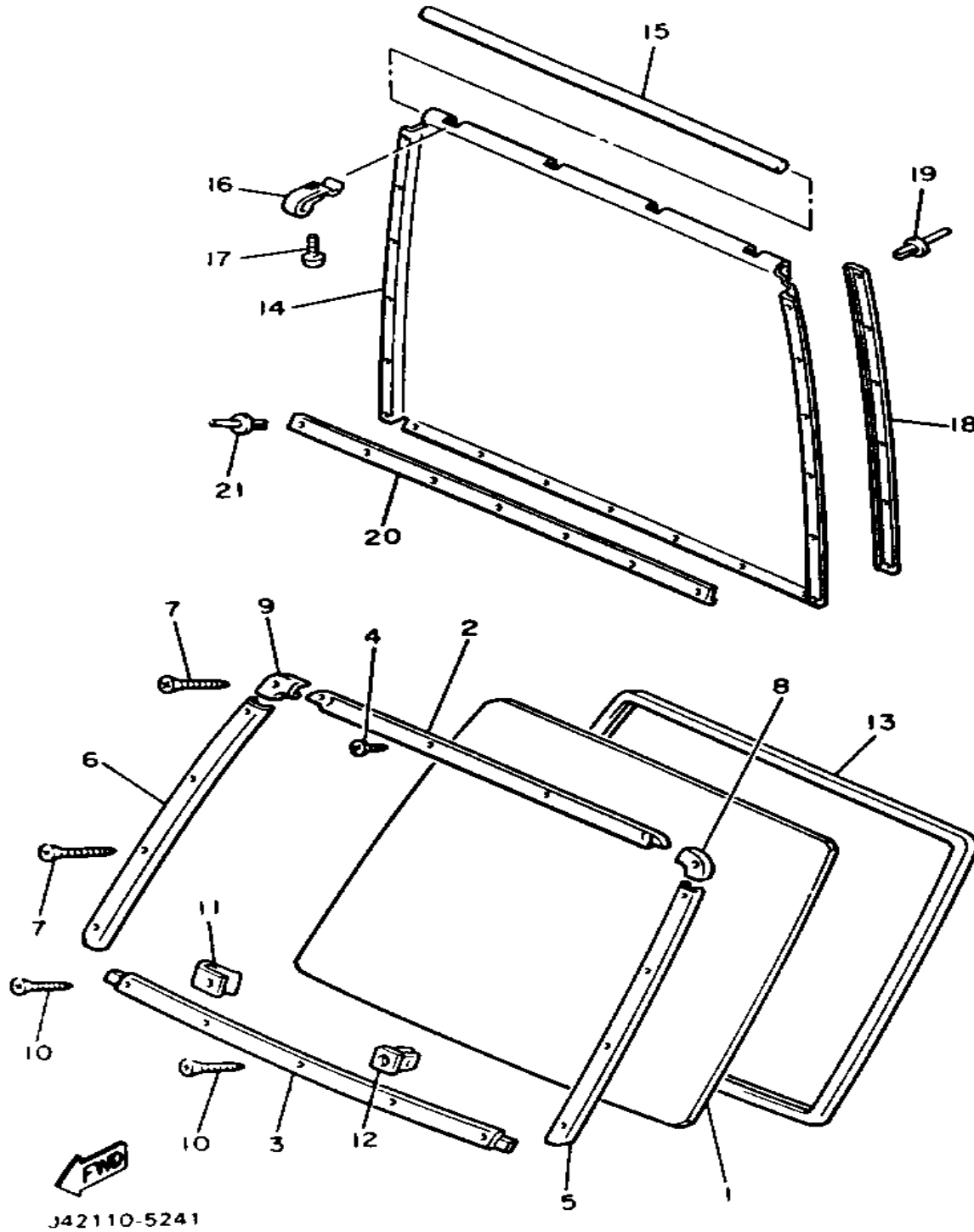

Ref. No.	Part Number	Description	Qty	Remarks
1	J42-77211-00-00	WINDSHIELD	1	
2	J42-77213-00-00	TRIM, upper	1	
3	J42-77226-00-00	TRIM 6	1	
4	97706-40716-00	SCREW, tapping	2	
5	J42-77214-00-00	TRIM, lower	1	
6	J42-77215-00-00	TRIM 3	1	
7	97706-40330-00	SCREW, tapping	12	
8	J42-77216-00-00	TRIM 4	1	
9	J42-77225-00-00	TRIM 5	1	
10	97-70640-72-50	SCREW, tapping	5	
11	90183-04056-00	NUT, spring	2	
12	(90480-07449-00)	GROMMET	3	
13	J42-77227-01-00	PACKING, windshield	1	
14	J42-77232-00-00	CURTAIN, rear	1	
15	J42-77235-00-00	STIFFENER	1	
16	J42-77236-00-00	BRACKET, curtain	4	
17	98580-05010-00	SCREW, PAN HEAD	4	
18	J42-77233-00-00	TRIM 7	2	
19	90267-63134-00	RIVET, BLIND	12	
20	J42-77234-00-00	TRIM 8	1	
21	90267-63134-00	RIVET, BLIND	7	

# CARRIER

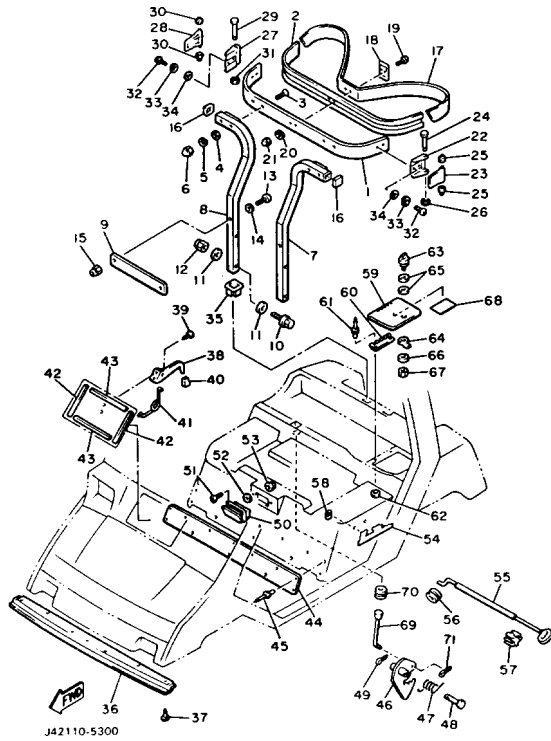

Ref. No.	Part Number	Description	Qty	Remarks
1	J42-78351-00-00	SUPPORT, BAG UPPER (J10-78351-00-9E)	1	
2	J10-78356-00-00	PAD, BAG SUPPORT	1	
3	98701-08045-00	SCREW, FLAT HEAD (92701-08045)	4	
4	90202-08022-00	WASHER, PLATE	4	
5	92990-08100-00	WASHER	4	
6	95380-08800-00	NUT, CROWN	4	
7	J42-78352-00-00	SUPPORT, bag lower 1	1	
8	J42-78353-00-00	SUPPORT, bag lower 2	1	
9	J42-78367-00-00	PLATE, anchor	1	
10	95811-08050-00	BOLT, FLANGE (95812-08050)	4	
11	90201-084K3-00	WASHER, PLATE	8	
12	95601-08200-00	NUT, U	4	
13	90154-08028-00	SCREW, binding	2	
14	90201-080A9-00	WASHER, plate	2	
15	95601-08200-00	NUT, U	2	
16	J10-78139-00-00	CAP, END	2	
17	J10-78355-00-00	BAND	1	
18	J10-78367-00-00	PLATE, ANCHOR	1	
19	98980-06016-00	SCREW, BINDING	2	
20	92995-06100-00	WASHER, SPRING	2	
21	95380-06800-00	NUT	2	
22	J17-78157-01-00	BASE, LOCK	1	
23	J17-78368-00-00	LEVER, LOCK	1	
24	J17-78369-00-00	PIN, LEVER	1	
25	90386-06108-00	BUSH	2	
26	99080-05600-00	CIRCLIP	1	
27	J17-78157-01-00	BASE, LOCK	1	

CONTINUED ON NEXT FRAME ►

# CARRIER

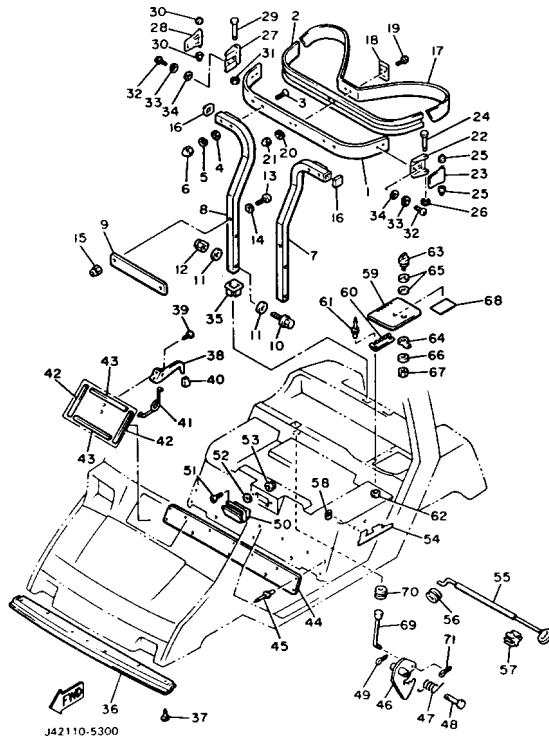

Ref. No.	Part Number	Description	Qty	Remarks
28	J17-78368-01-00	LEVER, LOCK .....	1	
29	J17-78369-00-00	PIN, LEVER .....	1	
30	90386-06108-00	BUSH .....	2	
31	99080-05600-00	CIRCLIP .....	1	
32	98580-06010-00	SCREW, PAN HEAD (92503-06010) .....	4	
33	92995-06100-00	WASHER, SPRING .....	4	
34	92990-06200-00	WASHER .....	4	
35	(90480-36427-00)	GROMMET .....	2	
36	J42-78216-00-00	COVER, bumper gap .....	1	
37	90269-06028-00	RIVET .....	6	
38	(J42-7827F-01-00)	LEVER, VENTILATOR .....	1	
39	97780-50612-00	SCREW, TAPPING .....	2	
40	(J42-7827G-00-00)	KNOB, VENTILATOR .....	1	
41	J42-7827H-00-00	SPRING, ventilator .....	1	
42	J42-78245-00-00	SEAL 1 .....	2	
43	J42-78246-00-00	SEAL, floor 2 .....	2	
44	J42-78119-00-00	PLATE 3 .....	1	
45	90267-40075-00	RIVET, BLIND .....	10	
46	ϕJ4-27814-H0-20	HOOK, body lock .....	1	
47	ϕ90-50814-69-80	SPRING, torsion .....	1	
48	(91702-08040-00)	PIN, CLEVIS .....	1	
49	91401-25020-00	PIN, COTTER .....	1	
50	J42-78287-00-00	ASH TRAY .....	1	
51	(98780-04025-00)	SCREW, FLAT HEAD .....	2	
52	92990-04200-00	WASHER, PLAIN .....	2	
53	95701-04300-00	NUT, flange .....	2	
54	J42-78291-00-00	EMBLEM 1 .....	2	
55	J42-78375-00-00	SUPPORT 1 .....	1	

CONTINUED ON NEXT FRAME ►

# CARRIER

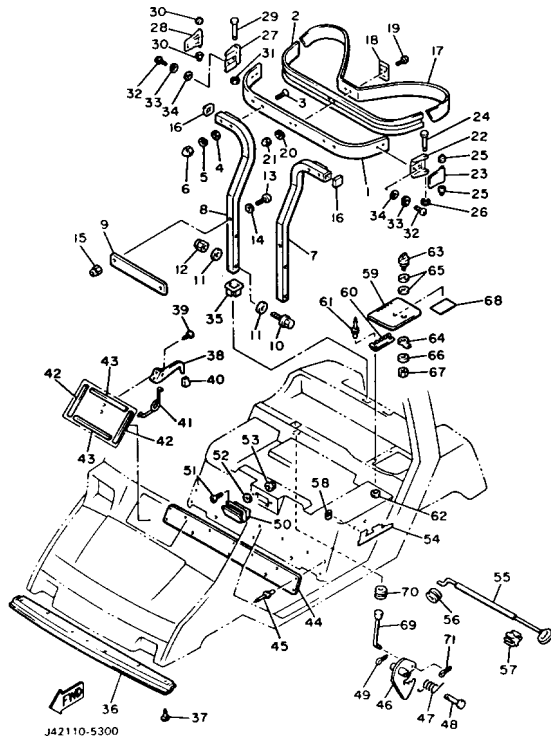

Ref. No.	Part Number	Description	Qty	Remarks
56	90480-16304-00	GROMMET (90480-16110-00) ..	1	
57	J42-78359-00-00	HOLDER 3 .....	1	
	J42-78359-01-00	HOLDER 3 0 1 .....	1	122~
58	90183-03038-00	NUT, spring .....	4	
59	J42-78272-00-00	COVER, fuel inlet .....	1	
60	J17-78275-00-00	HINGE.FUEL INLET .....	1	
61	90267-40075-00	RIVET, BLIND .....	2	
62	90201-04M06-00	WASHER, PLATE .....	2	
63	8L9-77324-00-00	KNOB .....	1	
64	8K4-77328-00-00	LEVER, arm fitting .....	1	
65	90206-15070-00	WASHER, wave .....	2	
66	90201-05725-00	WASHER, PLATE .....	1	
67	95706-05300-00	NUT, nylon .....	1	
68	J24-77764-00-00	LABEL, WARNING 4 .....	1	
69	(J42-7814G-02-00)	LEVER, BODY LOCK .....	1	
70	90480-12067-00	GROMMET .....	1	
71	91490-16020-00	PIN, COTTER .....	1	

## SEAT

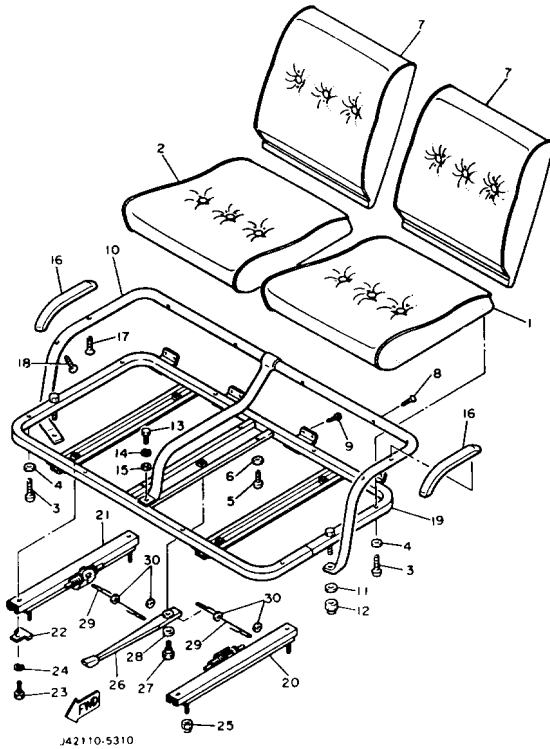

Ref. No.	Part Number	Description	Qty	Remarks
1	J50-K8401-00-00	SEAT SB/ASSEMBLY, CSHN ..	1	
2	J50-K8403-00-00	SEAT SB/ASSEMBLY, CSH 2 .	1	
3	98580-06040-00	SCREW, pan head (92501-06040-00) .....	8	
4	90201-065F3-00	WASHER, PLATE .....	8	
5	98501-06014-00	SCREW, pan head (92501-06014-00) .....	4	
6	90201-061A5-00	WASHER, PLATE .....	4	
7	J50-K8402-00-00	SEAT SB/ASSEMBLY, BACK ..	2	
8	90152-06017-00	SCREW, COUNTERSUNK .....	4	
9	97780-50316-00	SCREW, TAPPING .....	8	
10	J42-78421-00-00	SUPPORT, seat .....	1	
11	92990-08600-00	WASHER, PLATE .....	2	
12	95680-08100-00	NUT, U .....	2	
13	97022-08016-00	BOLT .....	1	
14	92990-08100-00	WASHER .....	1	
15	92990-08600-00	WASHER, PLATE .....	1	
16	J42-78361-00-00	ARM REST 1 .....	2	
17	98680-05030-00	SCREW, OVAL HEAD .....	2	
18	97780-50330-00	SCREW, TAPPING .....	2	
19	J42-78451-00-00	FRAME, slide seat .....	1	
20	J42-78452-00-00	SEAT-ADJUSTER 1 .....	1	
21	J42-78453-00-00	SEAT-ADJUSTER 2 .....	1	
22	J42-78454-00-00	STOPPER, slide seat .....	2	
23	97022-08016-00	BOLT .....	4	
24	92990-08100-00	WASHER .....	4	
25	95601-08200-00	NUT, U .....	4	
26	J42-78455-00-00	LEVER, adjuster .....	1	
27	J42-78456-00-00	BOLT, adjuster .....	1	

CONTINUED ON NEXT FRAME ►

# SEAT

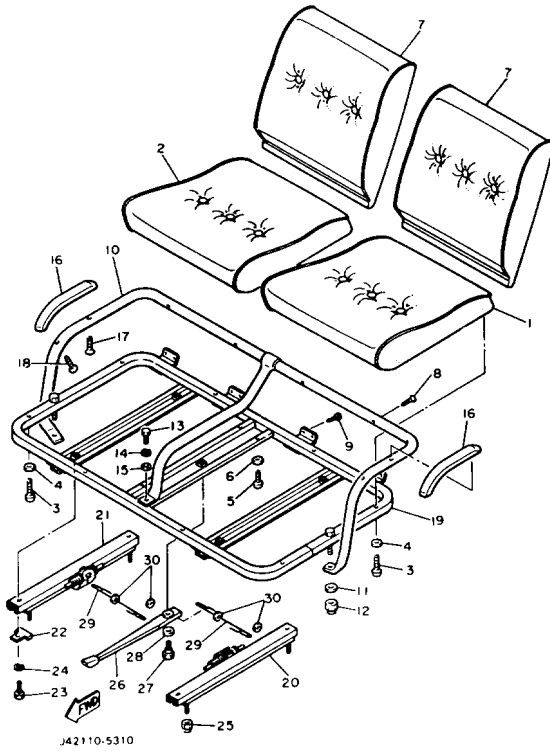

Ref. No.	Part Number	Description	Qty	Remarks
28	92990-10600-00	WASHER, PLATE .....	1	
29	J42-78457-00-00	WIRE, adjuster .....	2	
30	92901-04600-00	WASHER, PLATE .....	4	

# STARTING MOTOR

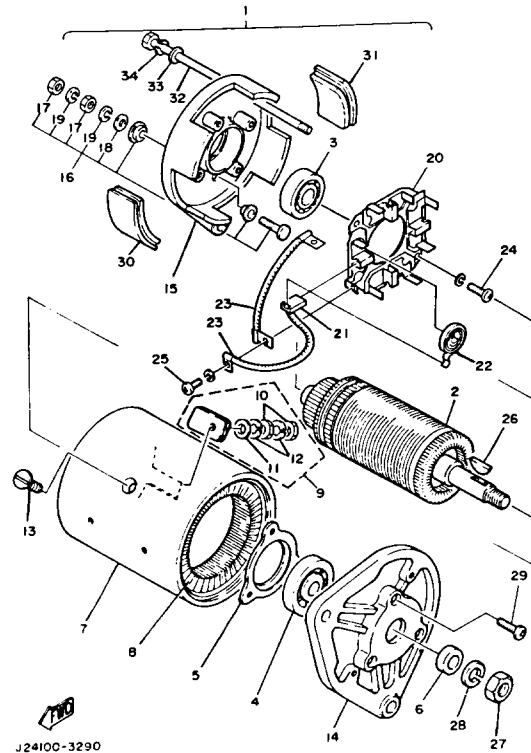

Ref. No.	Part Number	Description	Qty	Remarks
1	J10-81100-10-00	STARTER GEN ASSEMBLY ASSY	1	
2	J10-81150-10-00	. ARMATURE ASSEMBLY	1	
3	J10-81157-10-00	. BEARING 1 (6202 SD)	1	
4	J10-81158-10-00	. BEARING 2 (6203 SD)	1	
5	J10-81159-10-00	. HOLDER, BEARING	1	
6	J10-81175-10-00	. STOPPER 1	1	
7	J10-81110-10-00	. STATOR ASSEMBLY	1	
8	J10-81160-10-00	. FIELD COIL ASSEMBLY	1	
9	J10-81148-10-00	. SCREW	2	
10	95380-06600-00	.. NUT	4	
11	90201-061A5-00	.. WASHER, PLATE	2	
12	92995-06100-00	.. WASHER, SPRING	4	
13	J10-81146-10-00	. SCREW	4	
14	J10-81165-10-00	. BRKT, STARTER GEN 1 GENERATOR 1	1	
15	J10-81166-10-00	. BRACKET, STARTER GENERATOR	1	
16	J10-81147-10-00	. SCREW	2	
17	95380-06600-00	.. NUT	4	
18	90201-061A5-00	.. WASHER, PLATE	2	
19	92995-06100-00	.. WASHER, SPRING	4	
20	J10-81119-10-00	. BRUSH HOLDER ASSEMBLY	1	
21	J10-81111-10-00	. BRUSH	4	
22	J10-81113-10-00	. SPRING, BRUSH	4	
23	J10-81115-10-00	. WIRE, LEAD	2	
24	98501-05016-00	. SCREW, PAN HEAD	2	
25	98580-04010-00	. SCREW, PAN HEAD	4	
26	J38-81163-10-00	. KEY	1	
27	95301-14700-00	. NUT	1	

CONTINUED ON NEXT FRAME ►

# STARTING MOTOR

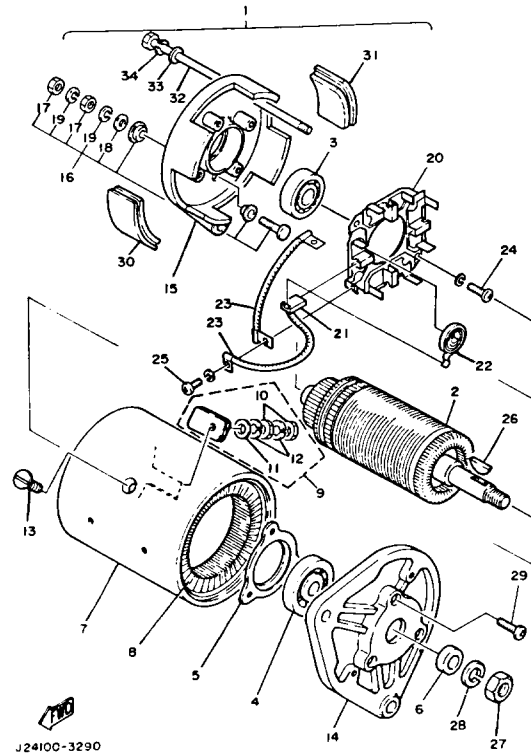

Ref. No.	Part Number	Description	Qty	Remarks
28	92901-14100-00	. WASHER, SPRING .....	1	
29	98501-05018-00	. SCREW, PAN HEAD .....	3	
30	J10-81129-10-00	. COVER, BRUSH .....	3	
31	J10-81129-10-00	. COVER, BRUSH .....	1	
32	J10-81145-10-00	. SCREW .....	2	
33	90201-061A5-00	. WASHER, PLATE .....	2	
34	92995-06100-00	. WASHER, SPRING .....	2	

# STARTER PULLEY

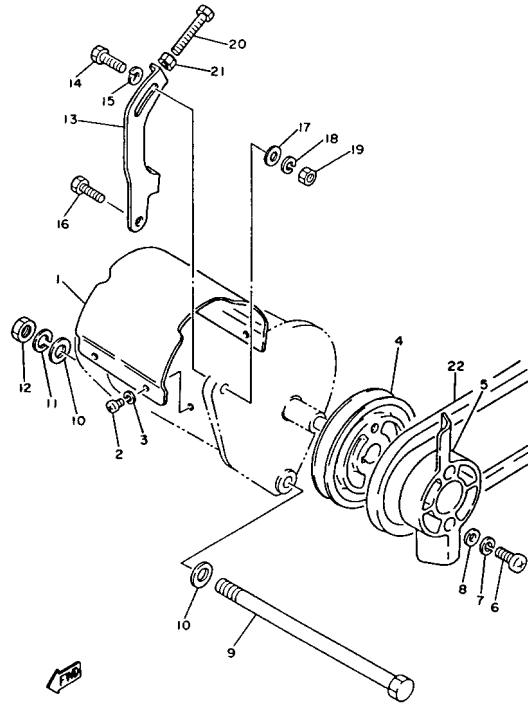

Ref. No.	Part Number	Description	Qty	Remarks
1	J17-87183-00-00	INSULATOR, GEN .....	1	
2	98501-05010-00	SCREW, PAN HEAD .....	4	
3	92990-05100-00	WASHER, SPRING .....	4	
4	J10-81161-01-00	PULLEY .....	1	
5	J10-87172-00-00	FAN, GENERATOR .....	1	
6	92501-06025-00	SCREW, pan head .....	2	
7	92995-06100-00	WASHER, SPRING .....	2	
8	92990-06600-00	WASHER, PLATE .....	2	
9	90101-12545-00	BOLT .....	1	
10	92990-12600-00	WASHER, PLATE .....	2	
11	92901-12100-00	WASHER, SPRING .....	1	
12	95303-12600-00	NUT .....	1	
13	J17-81170-00-00	TENSIONER ASSEMBLY (92902-08100) .....	1	
14	97313-08020-00	BOLT, HEXAGON .....	1	
15	92990-08100-00	WASHER .....	1	
16	90109-08653-00	BOLT .....	1	
17	92990-08600-00	WASHER, PLATE .....	1	
18	92990-08100-00	WASHER .....	1	
19	95303-08600-00	NUT .....	1	
20	90101-06410-00	BOLT .....	1	
21	95380-06700-00	NUT .....	1	
22	J10-81173-00-00	BELT .....	1	

# MAGNETO

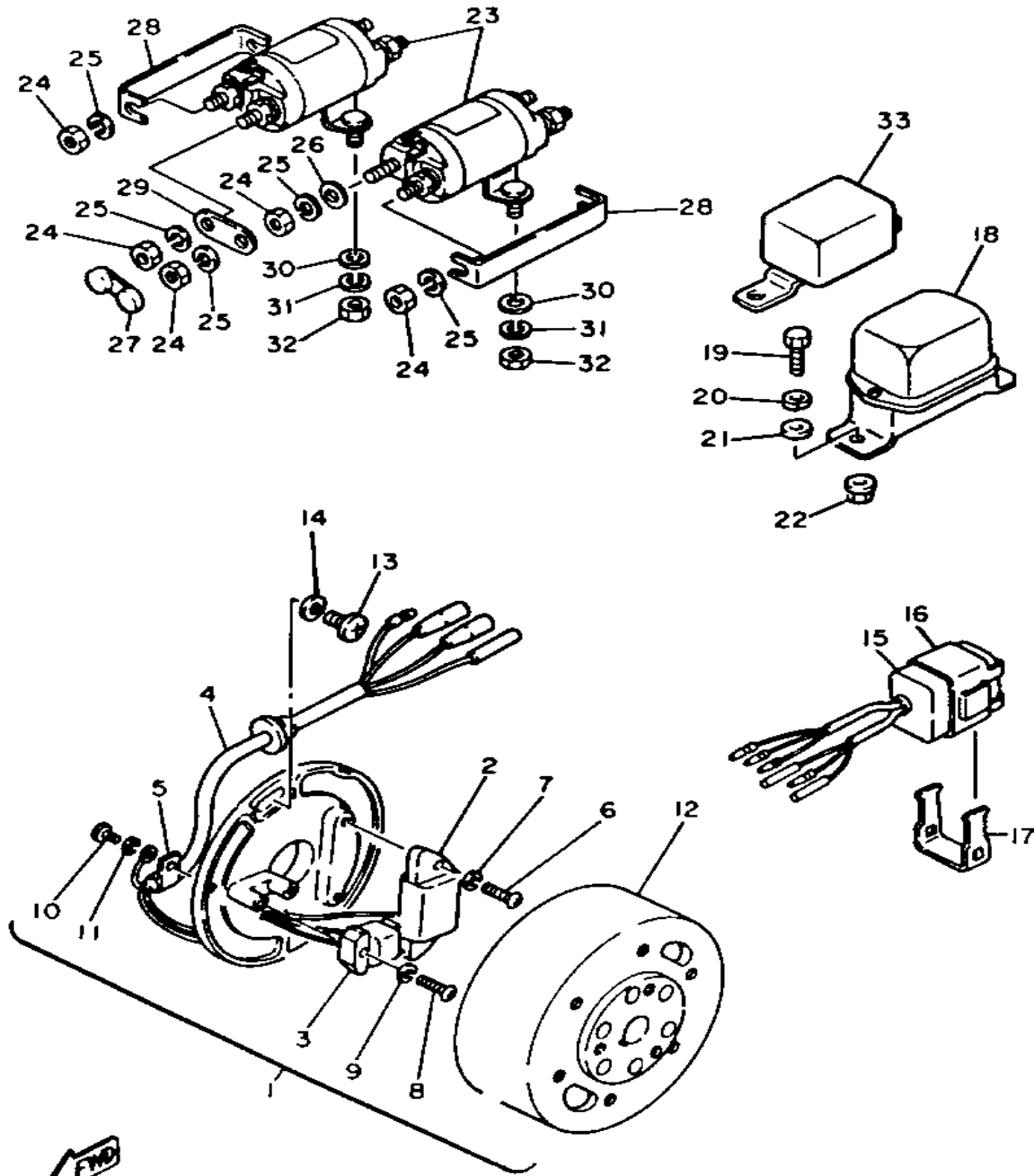

**FWD**  
J42110-5320

Ref. No.	Part Number	Description	Qty	Remarks
1	J10-85500-20-00	CDI MAGNETO ASSEMBLY ...	1	
2	8G8-85511-20-00	. COIL SOURCE 1 .....	1	
3	J10-85580-20-00	. COIL, PULSER .....	1	
4	J10-85515-20-00	. LEAD WIRE ASSEMBLY ....	1	
5	104-81328-20-00	. CLAMP .....	2	
6	98580-05020-00	. SCREW, PAN HEAD .....	2	
7	92990-05100-00	. WASHER, SPRING .....	2	
8	98511-04020-00	. SCREW, PAN HEAD .....	2	
9	92901-04600-00	. WASHER, PLATE .....	2	
10	98580-04008-00	. SCREW, PAN HEAD .....	1	
11	92901-04600-00	. WASHER, PLATE .....	1	
12	J10-85550-20-00	. ROTOR ASSEMBLY .....	1	
13	98980-06016-00	SCREW, BINDING .....	2	
14	90201-06043-00	WASHER, PLATE .....	2	
15	J10-85540-20-00	CDI UNIT ASSEMBLY .....	1	
16	2A7-85546-00-00	BAND .....	1	
17	82M-21245-00-00	BOX .....	1	
18	J10-81910-10-00	VOLTAGE REG ASSEMBLY ASSY .....	1	
19	97313-06016-00	BOLT, HEXAGON .....	2	
20	92995-06100-00	WASHER, SPRING .....	2	
21	92990-06600-00	WASHER, PLATE .....	2	
22	95702-06600-00	NUT, FLANGE .....	2	
23	J17-81950-01-00	RELAY ASSEMBLY .....	2	
24	95303-08700-00	. NUT .....	8	
25	92990-08100-00	. WASHER .....	8	
26	92990-08600-00	. WASHER, PLATE .....	4	
27	J24-82532-00-00	CAP .....	4	
28	J17-86126-00-00	PLATE, CONNECTING 1 .....	2	

CONTINUED ON NEXT FRAME ►

# MAGNETO

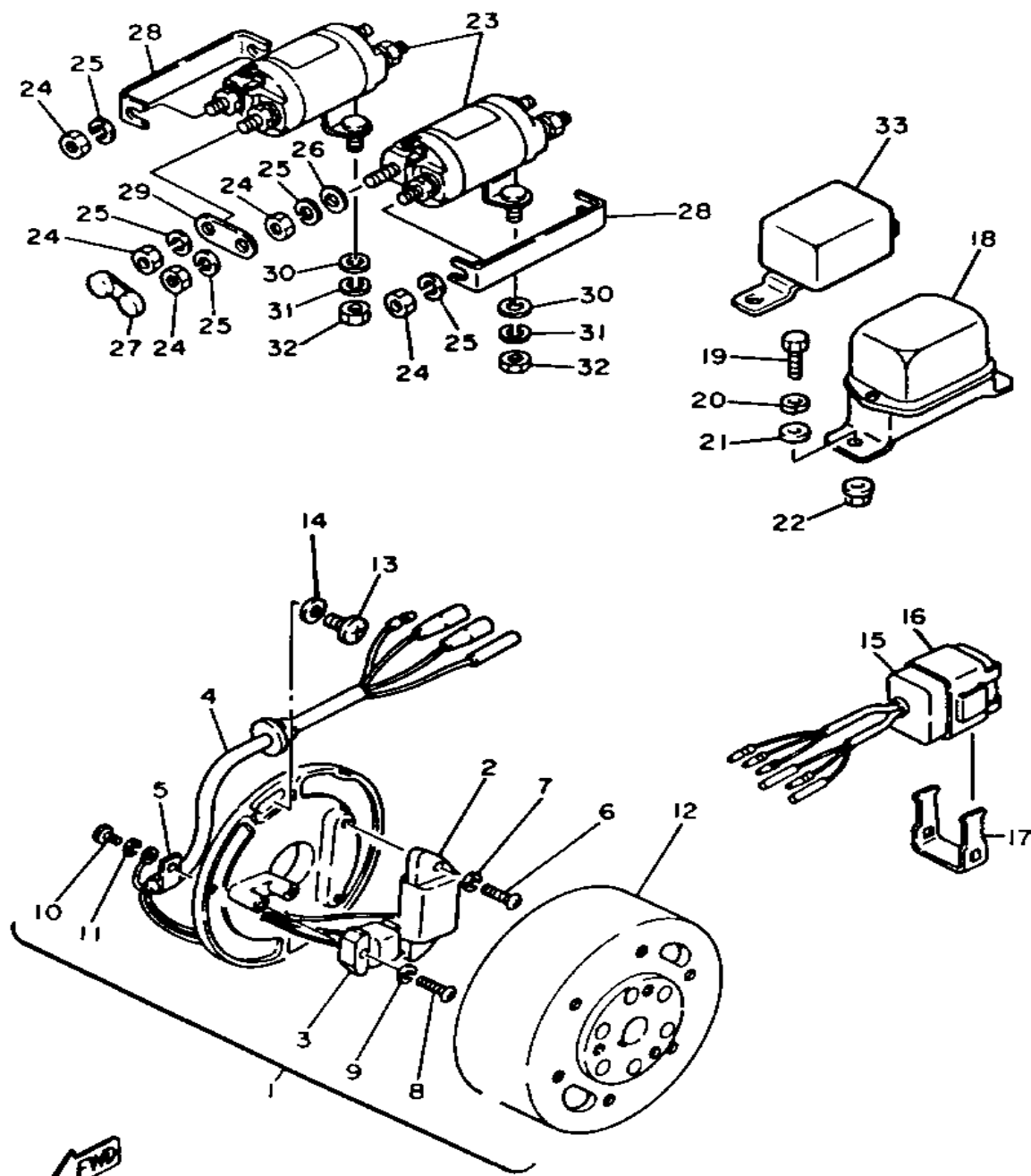

J42110-5320

Ref. No.	Part Number	Description	Qty	Remarks
29	J17-86127-00-00	PLATE, CONNECTING 2	2	
30	92990-08200-00	WASHER, PLAIN	4	
31	92990-08100-00	WASHER	4	
32	95303-08600-00	NUT	4	
33	J17-81920-19-00	SOLENOID REBLD KIT	1	OPTIONAL PART
	J27-81950-01-00	RELAY ASSEMBLY.	1	

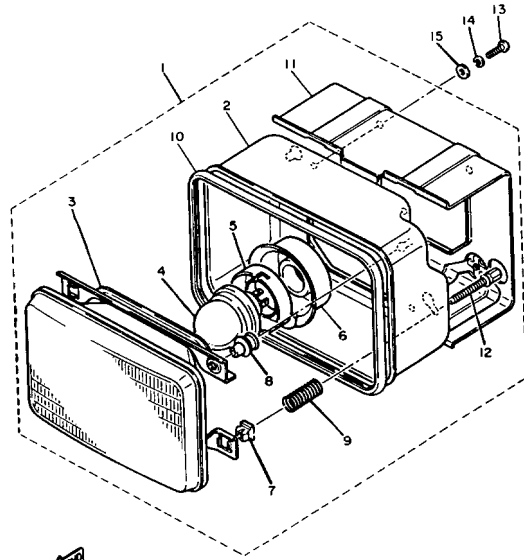

J42110-5360

# HEADLIGHT

Ref. No.	Part Number	Description	Qty	Remarks
1	J42-84300-00-00	HEADLIGHT ASS'Y	2	
2	J42-84330-00-00	. BODY ASS'Y	1	
3	J42-84320-00-00	. LENS ASS'Y	1	
4	1U4-84314-40-XX	. BULB, HEAD LIGHT (12V-45/40W)	1	
5	341-84393-40-00	. HOLDER, BULB	1	
6	46X-84396-00-00	. COVER	1	
7	51L-84334-00-00	. NUT, ADJUSTING	2	
8	51L-8431U-00-00	. HOLDER	1	
9	51L-84332-00-00	. SPRING, SCREW	2	
10	ϕJ4-28434-30-00	. MOLE, headlight	1	
11	ϕJ4-28431-80-00	. STAY, headlight 1	1	
12	ϕJ4-28433-10-00	. SCREW, rim adjusting	2	
13	98580-05020-00	SCREW, PAN HEAD	8	
14	92990-05100-00	WASHER, SPRING	8	
15	90201-05029-00	WASHER, PLATE	8	

# TAILLIGHT

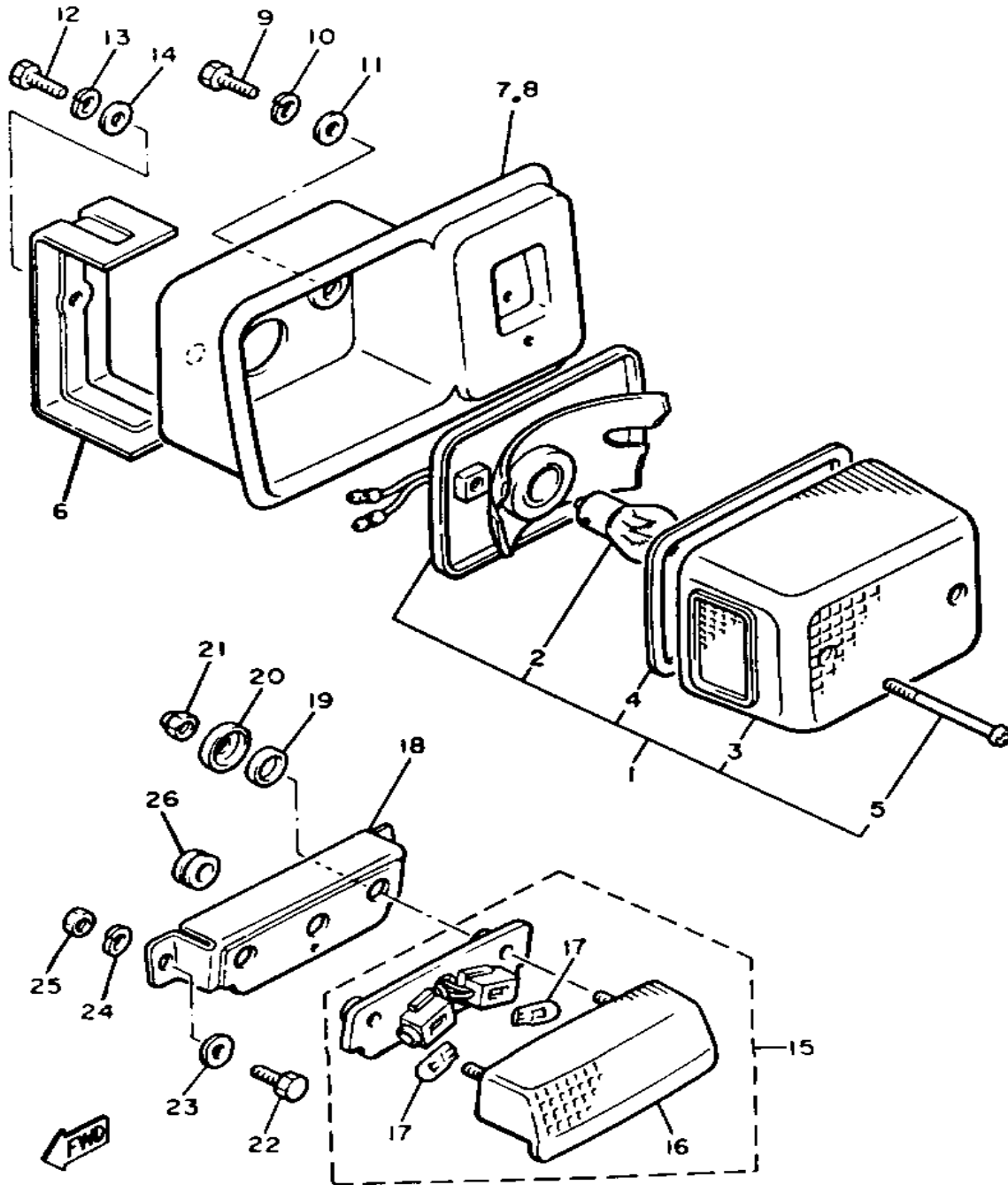

J42110-5370

Ref. No.	Part Number	Description	Qty	Remarks
1	13W-84710-00-00	TAILLIGHT UNIT ASS'Y	2	
2	256-84714-61-00	. BULB (12V-27/8W)	1	
3	1M8-84521-40-00	. LENS, TAILLIGHT	1	
4	1M1-84523-60-00	. GASKET, LENS	1	
5	1M1-84524-60-00	. SCREW, LENS FITTING	2	
6	J42-84702-00-00	BRACKET, taillight	2	
7	J42-84716-00-00	COVER, taillight	1	
8	J42-84716-50-00	COVER, taillight	1	
9	97313-06016-00	BOLT, HEXAGON	2	
10	90201-063J2-00	WASHER, PLATE	2	
11	92990-06600-00	WASHER, PLATE	2	
12	97011-06025-00	BOLT (97001-06025)	2	
13	92995-06100-00	WASHER, SPRING	2	
14	92990-06600-00	WASHER, PLATE	2	
15	2AX-84745-00-00	LICENSE LIGHT UNIT ASS'Y (4H3-84745-60-00)	1	
16	4H3-84749-00-00	. BODY, license light	1	
17	3F9-84744-00-00	. BULB (12V-3.8W)	2	
18	J42-84751-00-XX	BRACKET, license (J42-84751-00-00)	1	
19	3G1-84553-00-00	DAMPER	2	
20	3F9-84754-00-00	WASHER, SPECIAL	2	
21	95701-05300-00	NUT, NYLON	2	
22	97016-06016-00	BOLT	2	
23	92995-06200-00	WASHER (92902-06200)	2	
24	92990-06100-00	WASHER, SPRING	2	
25	95380-06600-00	NUT	2	
26	90480-16422-00	GROMMET	1	

# TURNSIGNAL

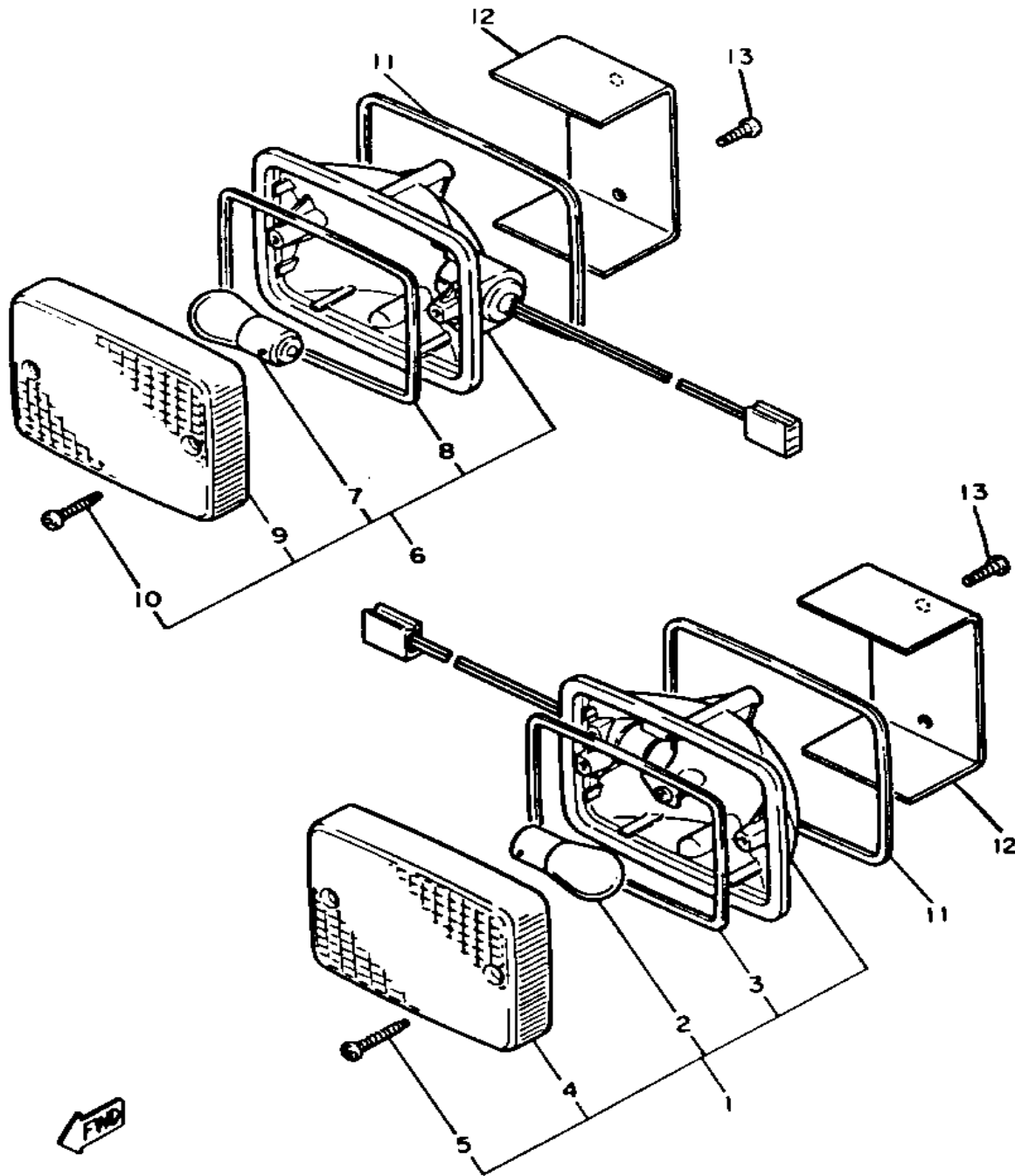

J42110-5350

Ref. No.	Part Number	Description	Qty	Remarks
1	J42-83310-00-00	FRONT FLASHER LIGHT ASS'Y 1	1	
2	256-84714-61-00	. BULB (12V-27/8W)	1	
3	4G0-83313-00-00	. GASKET, FLSHR LENS	1	
4	4G0-83312-00-00	. LENS, FLASHER	1	
5	ϕ97-70140-61-80	. SCREW, tapping	2	
6	J42-83320-00-00	FRONT FLASHER LIGHT ASS'Y 2	1	
7	256-84714-61-00	. BULB (12V-27/8W)	1	
8	4G0-83313-00-00	. GASKET, FLSHR LENS	1	
9	4G0-83312-00-00	. LENS, FLASHER	1	
10	ϕ97-70140-61-80	. SCREW, tapping	2	
11	J42-83321-00-00	DAMPER, flasher 1	2	
12	J42-83318-00-00	STAY, flasher 1	2	
13	97780-50514-00	SCREW, tapping (97702-50614-00)	4	

# ELECTRICAL 1

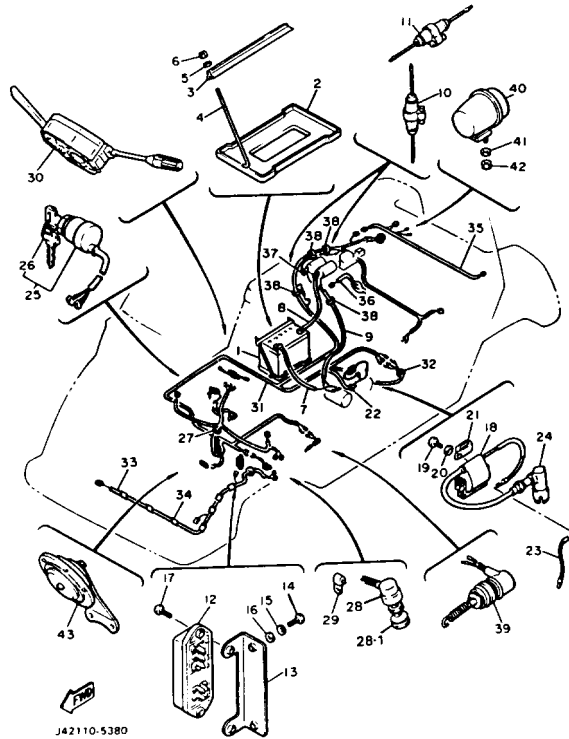

Ref. No.	Part Number	Description	Qty	Remarks
1	*---	FRONT WHEEL ASSEMBLY ..	1	LM (See Note)
2	J55-H2122-00-00	SEAT, BATTERY .....	1	
3	J55-H2136-00-00	PLATE, BATTERY .....	1	
4	J17-82133-00-00	SCREW, FITTING .....	2	
5	92990-06200-00	WASHER .....	2	
6	95701-06300-00	NUT, NYLON .....	2	
7	J10-82115-00-00	WIRE, PLUS LEAD .....	1	
8	J17-82116-00-00	WIRE, MINUS LEAD .....	1	
9	J17-82105-00-00	WIRE HARNESS .....	1	
10	J42-82150-50-00	FUSE HOLDER ASSEMBLY ...	1	
11	J42-82150-50-00	FUSE HOLDER ASSEMBLY ...	1	
12	J42-82170-00-00	FUSE BOX ASS'Y .....	1	
13	J42-82171-00-00	STAY, fuse box .....	1	
14	92580-06020-00	SCREW, PAN HEAD .....	2	
15	92995-06100-00	WASHER, SPRING .....	2	
16	92990-06600-00	WASHER, PLATE .....	2	
17	92503-06015-00	SCREW, pan head (92502-06016) .....	2	
18	5G4-82310-40-00	IGNITION COIL ASSEMBLY (J17-82310-21) .....	1	
19	98511-06025-00	SCREW PAN HEAD (92501-06025) .....	2	
20	92995-06100-00	WASHER, SPRING .....	2	
21	90465-06038-00	CLAMP .....	1	
22	90464-12036-00	CLAMP .....	1	
23	87D-82318-00-00	WIRE, SUB-LEAD .....	1	
24	512-82370-10-00	PLUG CAP ASSEMBLY .....	1	w/Noise Suppressor
25	J42-82510-20-00	MAIN SWITCH ASS'Y .....	1	
26	90890-55813-00	. KEY, main switch .....	1	
27	25G-83936-00-00	BAND, switch cord (256-83936-00-00) .....	1	

CONTINUED ON NEXT FRAME ➤

# ELECTRICAL 1

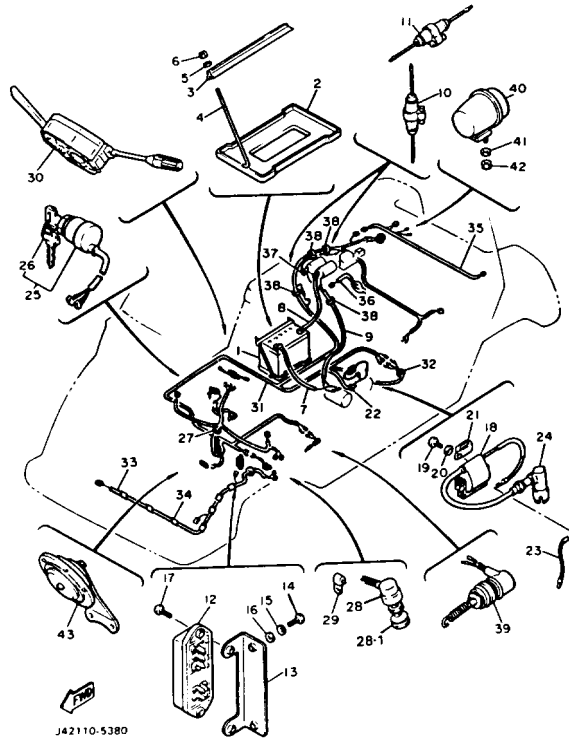

Ref. No.	Part Number	Description	Qty	Remarks
28	J17-82550-01-00	STOP SWITCH ASSEMBLY	1	
29	90465-06038-00	CLAMP	1	
30	J42-83975-00-00	SWITCH, HANDLE 2	1	
31	J42-82590-20-00	WIRE HARNESS ASS'Y	1	
32	437-83936-01-00	BAND, SWITCH CORD	1	
33	J42-82580-00-00	WIRE HARNESS ASS'Y 2	1	
34	φJ4-27717-E0-00	UNAVAILABLE IN PRICE BOOK	14	
35	J42-84727-00-00	CORD, taillight	1	
36	J17-86177-00-00	WIRE, LEAD 7	1	
37	J42-82318-00-00	WIRE, SUB-LEAD	1	
38	90464-12036-00	CLAMP	4	
39	J13-82530-00-00	STOP SWITCH ASS'Y	1	
40	J18-83383-00-00	BUZZER	1	
41	92990-06600-00	WASHER, PLATE	1	
42	95701-06300-00	NUT, NYLON	1	
43	J42-83371-00-00	HORN	1	
28-1	JF2-82532-00-00	. CAP, RUBBER	1	

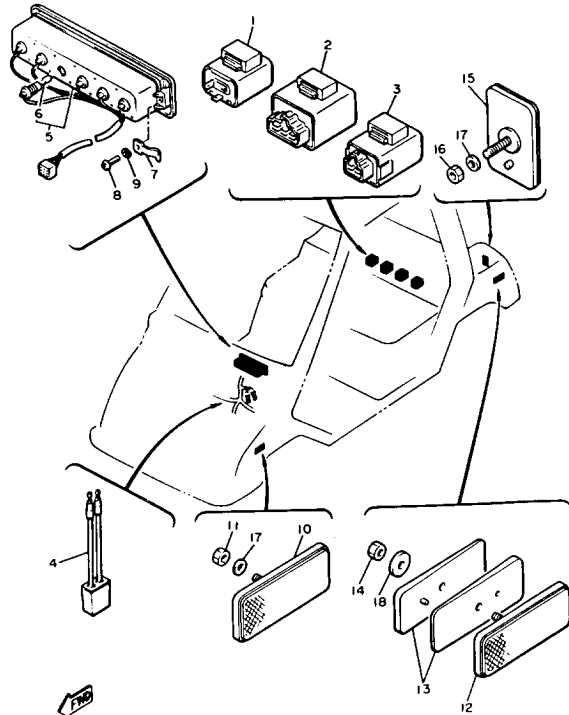

J42110-5390

## ELECTRICAL 2

Ref. No.	Part Number	Description	Qty	Remarks
1	33M-83350-20-00	FLASHER RELAY ASS'Y	1	
2	J42-83350-00-00	FLASHER RELAY ASS'Y	2	
3	J42-85590-01-00	CONTROL UNIT ASSEMBLY	1	
4	38W-85774-00-00	CHECKER, pilot lamp	2	
5	J42-83530-00-00	PILOT LIGHT ASS'Y	1	
6	4G1-84744-00-00	. BULB, MTR.12V3.4W	6	
7	J50-83514-00-00	PLATE, FITTING	2	
8	98501-05010-00	SCREW, PAN HEAD	2	
9	92901-04600-00	WASHER, PLATE	2	
10	11H-85110-01-00	REFLECTOR ASSEMBLY	2	
11	95701-05300-00	NUT, NYLON	2	
12	J42-85140-00-00	REAR REFLECTOR ASS'Y	2	
13	J42-85115-00-00	BASE, reflector	4	
14	95701-05300-00	NUT, NYLON	2	
15	J42-85130-00-00	REAR REFLECTOR ASS'Y	2	
16	95701-05300-00	NUT, NYLON	2	
17	92990-05200-00	WASHER, PLAIN	4	
18	90201-052E8-00	WASHER, plate	2	

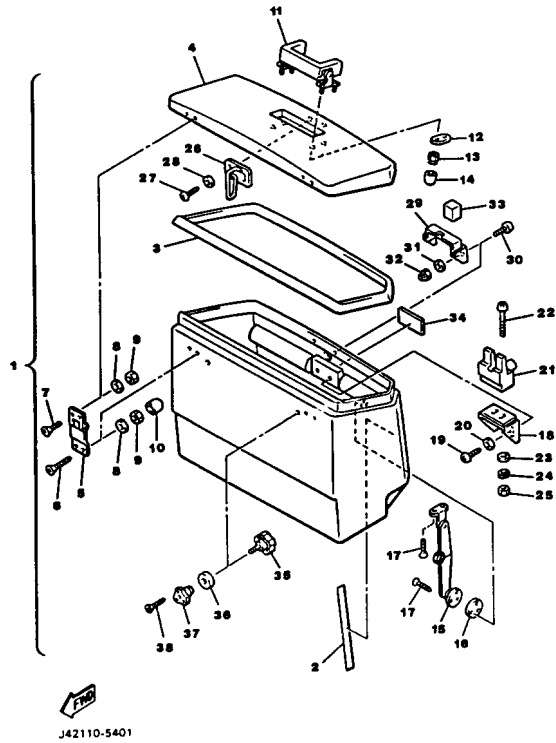

## ALTERNATE

Ref. No.	Part Number	Description	Qty	Remarks
1	ϕJ4-27810-R0-00	REAR STORAGE BOX	1	
2	ϕJ4-27824-G0-00	. TAPE 2	2	
3	J42-7815K-00-00	. SEAL, rear storage	1	
4	J42-7810N-00-00	. REAR STORAGE LID COMP	1	
5	J42-7815J-00-00	. HINGE, rear storage	2	
6	98701-05025-00	. SCREW, flat head	4	
7	98701-05016-00	. SCREW, FLAT HEAD	4	
8	92990-05200-00	. WASHER, PLAIN	8	
9	95701-05300-00	. NUT, NYLON	8	
10	90190-05008-00	. CLING	4	
11	(J42-28408-00-00)	GRIP, SADDLEBAG	1	
12	(26H-28458-00-00)	PATCH	2	
13	95701-05300-00	. NUT, NYLON	4	
14	90190-05008-00	. CLING	4	
15	J42-7831T-00-00	. SUPPORT, rear lid	1	
16	J42-78328-00-00	. SPACER 1	1	
17	97780-30312-00	. SCREW, tapping	5	
18	J42-78323-00-00	. BRACKET 1	1	
19	97780-60520-00	. SCREW, TAPPING	2	
20	92990-06600-00	. WASHER, PLATE	2	
21	(23T-24780-00-00)	SEAT LOCK ASSEMBLY	1	
22	98580-06040-00	. SCREW, pan head (92501-06040-00)	2	
23	92990-06600-00	. WASHER, PLATE	2	
24	92995-06100-00	. WASHER, SPRING	2	
25	95380-06600-00	. NUT	2	
26	J42-7831R-00-00	. HOOK, end 3	1	
27	97780-60116-00	. SCREW, TAPPING	2	
28	92990-06600-00	. WASHER, PLATE	2	

CONTINUED ON NEXT FRAME ►

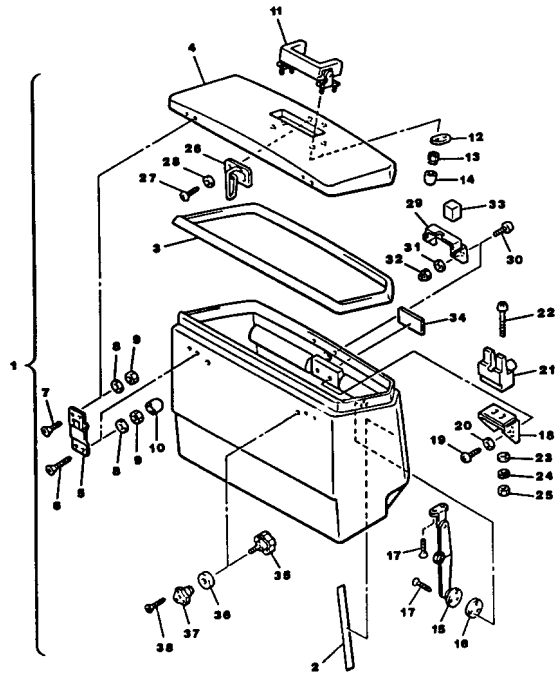

J42110-5401

## ALTERNATE

Ref. No.	Part Number	Description	Qty	Remarks
29	J42-78325-00-00	. BRACKET 3 .....	1	
30	98901-04010-00	. SCREW, BIND .....	2	
31	92901-04600-00	. WASHER, PLATE .....	2	
32	95701-04300-00	. NUT, flange .....	2	
33	J42-78316-00-00	. DAMPER .....	2	
34	25G-21578-00-00	. EMBLEM .....	1	
35	J42-78383-00-00	. KNOB .....	2	
36	J42-78329-00-00	. SPACER 2 .....	2	
37	(A00-65628-40-00)	INSERT NUT .....	2	
38	97780-30312-00	. SCREW, tapping .....	6	

## TECHNICAL BULLETIN

GOLF CAR DATE 1/10/86 RA G86-001

### G3

#### KEY/LOCK OR MAIN SWITCH REPLACEMENT

The G3 (Sun Classic) comes with one key that conveniently fits the main ignition switch, front trunk, and glove compartment. Retaining this feature for your customer could be difficult if keys are lost, or if locks and switches become inoperative for any reason. However, if the procedures outlined in this bulletin are followed, key, lock or main switch replacement on affected units will be easy.

#### AFFECTED UNITS

All G3

#### SERVICE PROCEDURES

#### KEY REPLACEMENT

The G3 (Sun Classic) has 250 different key combinations. It would not be practical to stock all key combinations. The following three steps will help if key replacement becomes necessary.

1. ALWAYS record the key number on all copies of the sales record at the time of sale. This number is stamped on the side of each key. This will ensure a permanent record of the key identification number. You can call YPDI to arrange for duplicate keys to be cut if this key number is known.
2. Tell your customer that a key may be duplicated at any regular locksmith or hardware store provided a proper blank is

available. YPDI offers a suitable blank key. See PARTS INFORMATION below.

3. If all keys are lost, and the key number is not known, the number can be read from the black sticker on the side of the main switch. However, this number is very difficult to read, and must be carefully inspected in bright light.

#### LOCK OR MAIN SWITCH REPLACEMENT

Many lock or main switch problems are due to a breakdown of the main switch mechanism, not the tumblers (that part of the lock or main switch turned by the key). If the customer wishes to retain the one-key system, the original tumblers should be removed from the original lock or main switch assembly, inspected by a reputable locksmith to ensure that the tumblers are indeed in good condition, and then installed in a new lock or main switch assembly by the locksmith.

**NOTE:** If a lock or switch assembly becomes inoperative, an entirely new lock or main switch assembly must be ordered from YPDI. A new key comes with every new lock or main switch assembly ordered. If the customer does not necessarily wish to retain the one-key system, simply replace the inoperative lock or main switch assembly with a new one. The customer will then have to use more than one key to operate all locks on the unit.

#### PARTS INFORMATION

PART NUMBER	DESCRIPTION	REMARKS	DEALER COST
J42-82510-20-00	Main Switch Assembly	(Ignition)	
J42-24765-00-00	Seat Lock Assembly	(Front Trunk)	
25G-21708-00-00	Side Cover Lock Assembly	(Glove box)	
90890-55813-00	Key Blank "K"		

#### WARRANTY

This bulletin is issued for informational purposes only; no special warranty procedures apply.

SERVICE COPY	SER MGR	MECH	MECH	MECH	INSTR
OFFICE COPY	GEN MGR	SALES	PARTS	INSTR	PAGE 1 OF 1

GOLF CAR DATE 1/31/86 RA G86-002

### G3-A

#### WINDSHIELD CLEANING

To avoid damage, care must be exercised while cleaning the G3-A acrylic plastic windshield. If it is wiped with a dry cloth, or while wet or dry dirt is present, the windshield may be scratched. Please perform the following procedure for proper windshield cleaning without scratching.

#### AFFECTED MODELS

All G3-A

#### SERVICE PROCEDURES

#### NORMAL CLEANING

1. Flush dirt off windshield with water from a hose. If there is more than just a light coat of dry dust, spray on soapy water before flushing.
2. Carefully dry the surface of the windshield using an extremely soft fabric. A flannel or a T-shirt type of material is best. Terry cloth or paper towels can possibly cause scratching to the windshield surface. Do not rub heavily!

#### PARTS INFORMATION

PART NUMBER	DESCRIPTION	DEALER COST
ACC-11000-15-01	Windshield Cleaner	

#### WARRANTY

This bulletin is issued for informational purposes only; no special warranty procedures apply.

SERVICE COPY	SER MGR	MECH	MECH	MECH	INSTR
OFFICE COPY	GEN MGR	SALES	PARTS	INSTR	PAGE 1 OF 1

## TECHNICAL BULLETIN

GOLF CAR DATE 4/30/86 RA G86-003

### G3-A

#### BODY ASSEMBLY

There has been some difficulty in properly aligning the rear body of the G3 during assembly. To make this easier, some assembly personnel have been using rivets to hold the rear body tightly against the middle body section.

However, using this method will eventually cause damage to the body panels through concentrated stress at points not designed to carry a load.

An alternative procedure is presented below.

#### AFFECTED UNITS

All G3-A

#### SERVICE PROCEDURES

- 1) Construct two spacers (using the dimensions given in the illustration) from a soft material such as plastic, rubber or soft wood.

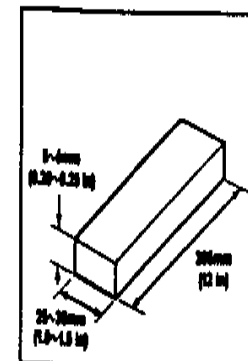

- 2) After the mounting bolts for the rear body and bag support have been installed, but not tightened, insert these spacers between the rear and middle body pieces (reference page 47 of the G3 assembly manual). While the rear body is being held tightly in place by a helper, tighten the securing bolts.

- 3) Once all the mounting bolts have been tightened, remove the spacers.

#### WARRANTY

This bulletin is issued for informational purposes only; no special warranty procedures apply.

SERVICE COPY	SER MGR	MECH	MECH	MECH	INSTR
OFFICE COPY	GEN MGR	SALES	PARTS	INSTR	PAGE 1 OF 1

GOLF CAR DATE 2/7/86 RA G86-004

### G3-A

#### PREVENTING TIRE CONTACT WITH FRAME

It is possible for the left front tire to contact the frame reinforcement and plastic body panel if the suspension compresses completely while making a hard left turn. This contact will cause noise, and may cause minor tire damage.

The frame must be modified in the area of the control pedal recess to prevent tire contact. Perform this modification on all affected units. The tire may still touch the body panel occasionally, but the tire will not be damaged by this contact.

#### AFFECTED UNITS

G3-A J42-00001 ~ 004673

#### SERVICE PROCEDURES:

1. Set the parking brake and jack up the car to elevate the left front wheel. Remove the wheel. Locate the area of the frame reinforcement that is closest to the tire as shown in the illustration. This is the area to be modified.

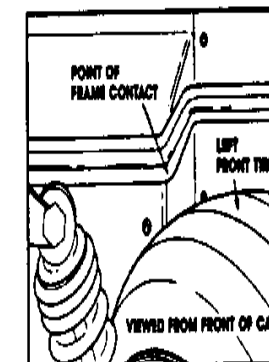

2. Using a disc grinder or cut-off wheel, make two notches in the frame approximately 30mm (1-3/16") apart as illustrated.

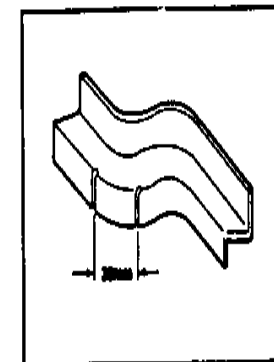

3. Using an iron bar and a heavy hammer, bend the portion of the frame within the notches back until it almost touches the body panel.

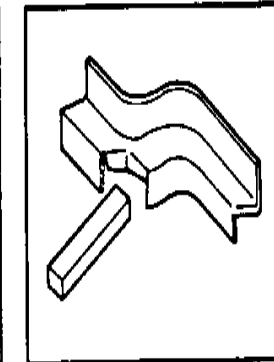

(For additional information see reverse side)

SERVICE COPY	SER MGR	MECH	MECH	MECH	INSTR
OFFICE COPY	GEN MGR	SALES	PARTS	INSTR	PAGE 1 OF 2

# TECHNICAL BULLETIN

GOLF CAR      DATE 11/19/86      RA G86-010

4. Also bend in the side tabs as shown to the point that they almost touch the body panel.

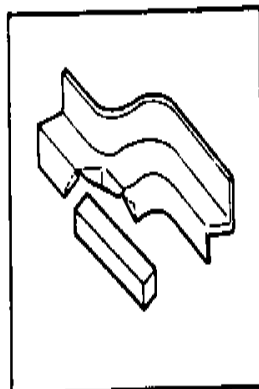

**NOTE:** Overinflation of the tires can cause excessive tire diameter, which can increase the chance of the tire rubbing on the frame. Be sure to keep the tires at the recommended pressure.

**TIRE PRESSURE:**  
0.8kg/cm<sup>2</sup> (12 psi)

**WARRANTY PROCEDURE**

The labor allowance for each unit modified is 0.2 hours, which includes reimbursement for the small amount of black paint used. To receive credit, file a standard service-per-bulletin Warranty Request using problem code 90NA.

**90NA**

Use this problem code but describe the defect

5. Paint the modified portion with gloss black paint. Gloss Black Paint is available in a spray can from YPOI (part number PNF-00000-00-33, dealer cost \$2.95).

6. Reinstall the wheel, and tighten the lug nuts.

**LUG NUT TIGHTENING TORQUE:**  
0.0m-tg (50 ft-lbs)

PAGE 2 OF 2

## G3-A APPEARANCE IMPROVEMENTS - DASH DECALS

Some units in the affected range may experience problems with the edges of the woodgrain dash decals lifting. To prevent this from occurring in the future, the factory has improved the process for degreasing dash surfaces before the

decals are applied. Should a unit in the affected range show signs of decals lifting at the edges, it will be necessary to re-adhere the edges that are lifting.

**AFFECTED UNITS**

G3A J42-000024 ~ 00499

**PROCEDURE**

1. Use Yamaha Plug and Point Cleaner, part number ACC-11001-14-01, to degrease the area under the lifting edges.
2. Once an area is degreased, use a clean rag to wipe the surfaces. Both decal and dash surfaces must be allowed to dry thoroughly.
3. Carefully apply a small amount of Yamaha Quick Gasket by YHTP, part number ACC-11001-05-01, to each edge of a decal that has lifted, and press the edges down. Make sure the edges have completely adhered to the dash at all points.
4. Repeat the procedure for any other decals whose edges have lifted.

**WARRANTY INFORMATION**

The labor allowance for this procedure is 0.1 hours per decal. There is no job code to receive payment. file a regular Warranty Request. The problem code is 27. Write "Per Bulletin G86-010" on field 10, and enter the labor on field 11 (0.1 hrs x number of decals repaired). Also write "Per Bulletin G86-010" on fields 13, 14, and 15.

**27**

Use this problem code but describe the defect

SERVICE COPY	SER MGR	MECH	MECH	MECH	INCR
OWNER COPY	SER MGR	SALTS	PARTS	INCR	PAGE 1 OF 1

# TECHNICAL BULLETIN

GOLF CAR      DATE 11/19/86      RA G86-011

## G3-A APPEARANCE IMPROVEMENTS - ARMREST PADS

Some units in the affected range may experience problems with paint peeling from the armrest pads. To prevent this condition from occurring in the future, the factory has improved the process for cleaning the armrest surfaces before paint is applied. Should any unit in the affected range show signs of paint peeling from either armrest, replacement will be necessary.

**AFFECTED UNITS**

G3A J42-000024 ~ 002096

**PROCEDURE**

Order a new armrest pad (see PARTS INFORMATION), and install it by removing and replacing the two countersunk screws.

**PARTS INFORMATION**

The armrest pad part number remains the same.

DESCRIPTION	PART NUMBER	REMARKS	DEALER COST
Armrest Pad	J42-78361-00-00	Now Improved	

**WARRANTY INFORMATION**

The labor allowance is 0.1 hours for each armrest. The problem code is 90HGL for the left side armrest pad, and 90HGR for the right side.

receive credit, follow the standard service-per-bulletin procedures.

Left Side:

**90HGL**

Use this problem code but describe the defect

Right Side:

**90HGR**

Use this problem code but describe the defect

SERVICE COPY	SER MGR	MECH	MECH	MECH	INCR
OWNER COPY	SER MGR	SALTS	PARTS	INCR	PAGE 1 OF 1

## ALL GAS-POWERED MODELS PRIMARY CLUTCH WEIGHT LINK WEAR

**INTRODUCTION**

**PROBLEM:** Some units in the affected ranges may experience premature wear of the primary clutch weight link assemblies. This usually occurs on units which accumulate high mileage, such as are used as industrial vehicles or fleet cars in high-usage areas.

**CAUSE:** Grease on the clutch weight links collects dirt which wears the clutch weight link bushings and pins.

**REMEDY:** Inspect, lubricate, and clean the area during routine maintenance. Install improved weight link kits and replace the pins if excess wear is found.

**DEALER ACTION SUMMARY**

1. Add inspection, lubrication, and cleaning of the primary clutch to the annual service procedures.

**NOTE:** Some of the common signs of worn weight links are squeaking, vibration, or rattling from the primary clutch.

2. If any unit experiences worn primary clutch weight links, install three improved weight link kits and replace the link pins.

3. File a service-per-bulletin warranty request for any repair.

**AFFECTED UNITS**

G1AM J31-140101 ~ 154371  
G2AM6 J38-000101 ~ 008999  
G2A J38-007101 ~ 019999  
J38-066101 ~ 070999

G2AB J38-020101 ~ 039499  
J38-071101 ~ 072305  
G3A J42-000101 ~ 002816

**SERVICE PROCEDURE**

**PERIODIC INSPECTION**

1. Open the rear cowling, and remove the drive belt.
2. Remove the primary clutch cap screws, and the clutch cap.
3. Inspect the sliding sheave for smooth operation. Check for play between the pivot pins and weight link assemblies.

• If the pins and weight link assemblies are not worn, and the sliding sheave operates smoothly, remove any dirt and old grease, and apply two to three shots of molybdenum disulfide grease to the grease fitting to lubricate the shaft. Remove any excess grease from the clutch and reassemble the unit. Greasing should be done only with clutch cap removed.



(for additional information see reverse side)

PAGE 1 OF 3

# TECHNICAL BULLETIN

GOLF CAR      DATE 12/31/87      NO. G87-008

**SERVICE PROCEDURE (Cont'd.)**

**CAUTION**

Make sure the clutch assembly is free of grease, oil, and dirt. Dirt will adhere to any grease or oil left on the clutch. This is the primary cause of premature wear of both the weight link bushings and pins, and the slider bushings.

- If any of the pins or weight link assemblies are worn, install three weight link kits and six pins.

**WEIGHT LINK INSTALLATION**

1. Disassemble the primary clutch according to the instructions in the service manual.
2. Follow the service manual and install the new links and pins. Do not lubricate these parts.

**NOTE:** The link kit contains different parts than were removed during disassembly. You must use the illustration in this bulletin to make sure the new parts are installed correctly.

3. Apply molybdenum disulfide grease to the grease fitting as necessary, remove any excess, and reassemble the unit.

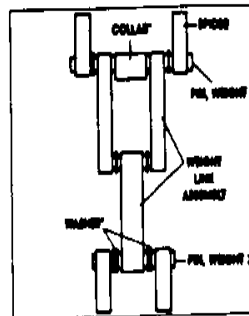
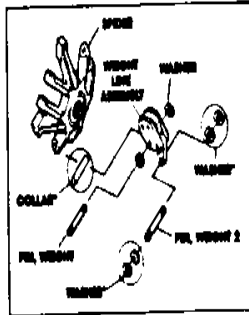

\*Newly added parts

**PARTS INFORMATION**

Part Number	Description	Qty	Remarks	Dealer Cost
9999-01831-00	Weight link kit	3	For G1-A and G3-A models	\$18.00
9999-01830-00	Weight link kit	3	For G2-A models	17.55
138-46236-00-00	Pin, Weight	3	For all models	70
138-46237-00-00	Pin, Weight 2	3	For all models	70

**NOTE:** Make sure the correct weight link kits are ordered (these kits contain the necessary collar and washers). Order three of the correct weight link kits and three of each of the two different pins for each unit.

**WARRANTY INFORMATION**

There is no warranty allowance for routine maintenance which includes inspection, cleaning, and lubrication.

Labor allowance for installing the weight link kit is 0.7 hours. The problem code is 90JD to receive credit. Follow normal service-per-bulletin procedures.

90JD      0.7  
Use this problem code and labor allowance for credit.

ROUTE TO:  SERVICE    PARTS    WARRANTY    SALES    PAGE 1 OF 3